



WELDING FILLER METAL HANDBOOK

2025 EDITION

All the strength and productivity your job needs and more. Let our world-renowned filler metals help you reach your project's true potential.

Filler Metals Made for More.

CLASSIFICATIONS INDEX	I
MILD STEEL	1-1
LOW ALLOY	2-1
MILD STEEL/LOW ALLOY SUBARC (SAW) FLUXES	3-1
STAINLESS STEEL	4-1
NICKEL	5-1
ALUMINIUM	6-1
COPPER	7-1
HARDFACING	8-1
REPAIR & MAINTENANCE	9-1
CERAMIC BACKING	10-1
PACKAGING & SPOOL TYPES	11-1
STORAGE & HANDLING	12-1
QUICK GUIDE FOR SELECTION OF WELDING CONSUMABLES	13-1
GENERAL INFORMATION & TABLES	14-1
WELDING HEAT-RESISTANT STEELS	15-1
WELDING OF WEATHER-RESISTANT STRUCTURAL STEELS	16-1
WELDING CONSUMABLES FOR HIGH-STRENGTH STEELS & FINE-GRAIN STEELS (RE ≥ 485 MPA)	17-1
WELDING CONSUMABLES FOR COLD-RESISTANT STEELS (≤ -60°C)	18-1
WELDING CONSUMABLES FOR CREEP RESISTANT STEELS	19-1
WELDING CONSUMABLES FOR CAST IRON	20-1
WELDING GUIDE FOR HETEROGENEOUS JOINTS WITH DIFFERENT TYPES OF STEEL	21-1
INFORMATION ON WELDING FERRITE-AUSTENITE STEELS (DUPLEX/LEAN & SUPER DUPLEX)	22-1



The information provided regarding filler metals is accurate as of the date of publication; however, ESAB reserves the right to modify product specifications, availability, and other details without prior notice. Users are advised to consult ESAB's official website at esab.com for the most current and accurate information. ESAB assumes no liability for reliance on outdated or superseded data.

MILD STEEL			
Product Name	EN/ISO	AWS	Page
STICK ELECTRODES			
OK 43.32	E 42 0 RR 12	E6013	1-6
OK 46.00	E 38 0 RC 11	E6013	1-7
OK 46.16	E 38 0 RC 11	E7014	1-8
OK 46.30	E 38 0 R 12	E6013	1-9
OK 46.44	E 38 0 RC 11	E6013	1-10
OK 48.00	E 42 4 B 42 H5	E7018 H4 R	1-11
OK 48.04	E 42 4 B 32 H5	E7018	1-13
OK 48.10 RMn	E 42 4 B 42 H5	E7018 H4 R	1-14
OK 48.50	E 42 4 B 32 H5	E7018-1 H4R	1-15
OK 48.60	E 42 4 B 42 H5	E7018	1-16
OK 50.40	E 42 2 RB 12	E6013	1-17
OK 53.05	E 42 4 B 22 H10	E7016	1-18
OK 53.16 Spezial	E 38 2B 32 H10	E7016	1-19
OK 53.68	E 42 5 B 12 H5	E7016-1 H4 R	1-20
OK 53.70	E42 5 B 12 H5	E7016-1	1-21
OK 55.00	E 46 5 B 32 H5	E7018-1H4 R	1-22
OK Femax 33.60	E 42 0 RR 53	E7024	1-24
OK Femax 33.80	E 42 0 RR 73	E7024	1-25
OK Femax 38.65	E 42 4 B 73 H5	E7028	1-26
OK Femax 38.95	E 38 4 B 73 H10	E7028	1-27
OK Femax 39.50	E 42 2 RA 53	E7027	1-28
OK GoldRox	E 42 0 RC 11	E6013	1-29
Pipeweld 6010 Plus	E 38 2 C 21	E6010	1-30
MIG WIRES/TIG RODS (GMAW/GTAW)			
Filarc PZ6500	W 3Si1 / W 42 3 3Si1	ER70S-6	1-31
OK AristoRod 12.50	G 38 3 C1 3Si1 / G 3Si1 / G 42 4 M20 3Si1 / G 42 4 M21 3Si1	ER70S-6	1-32
OK AristoRod 12.57	G 2Si / G 35 2 C1 2Si / G 38 3 M21 2Si	ER70S-3	1-34
OK AristoRod 12.62	G 2Ti / G 42 3 C1 2Ti / G 46 4 M21 2Ti	ER70S-2	1-36
OK AristoRod 12.63	G 42 3 C1 4Si1 / G 46 5 M20 4Si1 / G 46 5 M21 4Si1 / G 4Si1 / G 55A 5 M21 S6 / G S6	ER70S-6	1-37
OK AristoRod 38 Zn	G 42 3 M20 Z 3Si1 / G 42 3 M21 Z 3Si1 / G Z 3Si1	ER70S-G	1-39
OK Autrod 12.51	G 38 3 C1 3Si1 / G 3Si1 / G 42 4 M20 3Si1 / G 42 4 M21 3Si1	ER70S-6	1-41
OK Autrod 12.56	G 38 2 C1 3Si1 / G 3Si1 / G 42 3 M21 3Si1		1-43

MILD STEEL

Product Name	EN/ISO	AWS	Page
OK Autrod 12.58	G 2Si / G 35 2 C1 2Si / G 38 3 M21 2Si	ER70S-3	1-44
OK Autrod 12.64	G 42 3 C1 4Si1 / G 46 5 M20 4Si1 / G 46 5 M21 4Si1 / G 4Si1 / W 46 3 4Si1 / W4Si1	ER70S-6	1-46
OK Autrod 12.64 HP	G 46 3 C1 4Si1 / G 4Si1 / G 50 5 M20 4Si1 / G 50 5 M21 4Si1 / W 4Si1	ER70S-6	1-48
OK Autrod 12.66	G 42 2 C1 4Si1 / G 46 3 M21 4Si1 / G 4Si1 / W 46 3 4Si1 / W 4Si1	ER70S-6	1-50
OK Autrod 42 LSW	G 42 3 M20 Z / G 42 3 M21 Z / G 49A 5 M20 SZ / G Z / SZ	ER70S-9	1-51
Pipeweld 70S-6	G 42 2 C1 4Si1 / G 46 3 M21 4Si1 / G4Si1 / W 46 3 4Si1 / W 4Si1	ER70S-6	1-52
Purus 42	G 38 3 C1 3Si1 / G 3Si1 / G 42 4 M20 3Si1 / G 42 4 M21 3Si1	ER70S-6	1-53
Purus 42 CF	G 38 3 C1 3Si1 / G 3Si1 / G 42 4 M20 3Si1 / G 42 4 M21 3Si1	ER70S-6	1-55
Purus 46	G 42 3 C1 4Si1 / G 46 4 M20 4Si1 / G 46 4 M21 4Si1 / G 4Si1	ER70S-6	1-57
Purus 46 CF	G 42 3 C1 4Si1 / G 46 4 M20 4Si1 / G 46 4 M21 4Si1 / G 4Si1	ER70S-6	1-59
Weld G3Si1	G 38 2 C1 3Si1 / G 3Si1 / G 42 3 M21 3Si1	ER70S-6	1-61
OK Gasrod 98.70	Oil	R60	1-62
OK Tigrod 12.60	W 2Si / W 38 4 2Si	ER70S-3	1-63
OK Tigrod 12.61	W 3Si1 / W 42 3 3Si1	ER70S-6	1-64
OK Tigrod 12.62	W 46 4 2Ti / W2Ti	ER70S-2	1-65
OK Tigrod 12.64	W 46 5 4Si1 / W 4Si1	ER70S-6	1-66
GAS-SHIELDED FLUX-CORED WIRES (FCAW/MCAW)			
Filarc PZ6111	T 42 2 1Ni R C1 3 H10 / T 46 2 1Ni R M21 3 H10	E70T1-G	1-67
Filarc PZ6111HS	T 42 2 1Ni R C1 3 H10 / T 46 2 1Ni R M21 3 H10	E70T1-GC H8 / E70T1-GM H8	1-68
Filarc PZ6113	T 42 3 P C1 1 H5 / T 46 4 P M21 1 H5 / T 46 4 P M24 1 H5	E71T-1C H4 / E71T-1M H8	1-69
Filarc PZ6113S	T 46 3 P C1 2 H5	E71T-9C H4	1-71
Coreweld 46 LS	T 46 4 M M20 2 H5 / T 46 4 M M21 2 H5	E70C-6M H4	1-72
Coreweld 46 RMn	T 46 4 M M21 2 H5	E70C-6M H4	1-73
Dual Shield Prime 71 LT H4	T42 4 P C1 1 H5 / T42 4 P M21 1 H5 / T494T12 1C1A H5 / T494T12 1M21A H5	E71T-1C/1M/9C-J/9M-J-H4 / E71T-12C-J/12M-J-H4	1-74
Dual Shield 46M RMn	T 46 3 P M21 2	E71T-1M H8	1-76

MILD STEEL			
Product Name	EN/ISO	AWS	Page
OK E71T-1	T 42 2 P C1 1 H5 / T 46 2 P M21 1 H10	E71T-1C H4 / E71T-1M H8	1-77
OK Tubrod 14.00S	SA AB 1 67 AC H5	F7A2-EC1	1-78
OK Tubrod 14.10	T 46 4 M M21 2 H5	E70C-6M H4	1-79
OK Tubrod 14.11	T 42 4 M M21 3 H5	E70C-6M H4	1-80
OK Tubrod 14.12	T 42 2 M C1 1 H10 / T 42 2 M M21 1 H10	E70C-6C / E70C-6M	1-81
OK Tubrod 14.13	T 42 2 M M21 2 H5	E70C-6M	1-82
OK Tubrod 15.00	T 42 3 B C1 2 H5 / T 42 3 B M21 2 H5	E71T-5C H4 / E71T-5M H4	1-83
OK Tubrod 15.00S	S 42 4 AB T3 (OK Flux 10.71)	F7A4-EC1 (OK Flux 10.71) / F7A5-EC1 (OK Flux 10.62)	1-84
OK Tubrod 15.14	T 46 2 P C1 1 H5 / T 46 3 P M21 2 H5	E71T-1C H8 / E71T-1M H8	1-85
SELF-SHIELDED FLUX-CORED WIRES (FCAW)			
Coreshield 8	T 42 2 Y N 2	E71T-8	1-86
Coreshield 15		E71T-14/GS	1-87
SUBARC (SAW)			
OK Autrod 12.10	S1	EL12	1-88
OK Autrod 12.20	S2	EM12	1-89
OK Autrod 12.22	S2Si	EM12K	1-90
OK Autrod 12.32	S3Si	EH12K	1-91
OK Autrod 12.40	S4	EH14	1-92
OK Tubrod 14.00S	SA AB 1 67 AC H5	F7A2-EC1	1-93
OK Tubrod 15.00S	S 42 4 AB T3 (OK Flux 10.71)	F7A4-EC1 (OK Flux 10.71) / F7A5-EC1 (OK Flux 10.62)	1-94

LOW ALLOY			
Product Name	EN/ISO	AWS	Page
STICK ELECTRODES (SMAW)			
Filarc 118	E 69 5 Mn2NiMo B 32 H5	E11018-M H4R	2-4
Filarc 76S	E 46 6 Mn1Ni B 32 H5	E7018-G H4R	2-5
Filarc 88S	E 50 6 Mn1Ni B 12 H5	E8016-G H4R	2-6
Filarc 98S	E 55 6 Mn1NiMo B T 32 H5	E9018-G	2-8
OK 48.08	E 46 5 1Ni B 32 H5	E7018-G H4R	2-9
OK 73.08	E 46 5 Z B 32	E8018-G	2-11
OK 73.15	E 46 5 1Ni B 4 2 H5	E8018-C3 H4R / E5518-C3	2-12
OK 73.68	E 46 6 2Ni B 32 H5	E8018-C1	2-14
OK 73.79	E 46 6 3 Ni B 12 H5	E8016-C2	2-16
OK 74.46	E Mo B 3 2 H5	E7018-A1	2-17

LOW ALLOY

Product Name	EN/ISO	AWS	Page
OK 74.70	E 50 4 Z B 42 H5	E8018-G	2-18
OK 74.78	E 55 4 MnMo B 3 2 H5	E9018-D1	2-19
OK 74.86 Tensitrode	E 62 4 Mn1NiMo B T 32 H5	E10018-D2	2-20
OK 75.75	E 69 4 Mn2NiCrMo B 42 H5	E11018-G	2-21
OK 75.78	E 89 6 Z B 32 H5		2-22
OK 76.18	E CrMo1 B 4 2 H5	E8018-B2	2-23
OK 76.28	E CrMo2 B 4 2 H5	E9018-B3	2-24
OK 76.35	E CrMo5 B 4 2 H5	E8015-B6 H4 R	2-25
OK 76.96	E (CrMo9) B 4 2 H5	E8015-B8	2-26
OK 76.98	E CrMo91 B 4 2 H5	E9015-B91 (nearest)	2-27
OK 78.16	E 69 A Z B 42	E9018-G	2-28
OK B2 SC	E CrMo1B 42 H5	E8018-B2-H4R	2-29
OK B3 SC	E CrMo2 B 32 H5	E9018-B3 H4 R	2-31
Pipeweld 90DH	E 55 6 Mn1Ni B 45 H5	E9045-P2 H4R	2-33
Pipeweld 7010 Plus	E 46 2 Z C 21	E8010-P1	2-34
Pipeweld 8010 Plus	E 50 2 1NiMo C 21	E9010-P1	2-35
Pipeweld 9010 Plus	E 42 2 Z C 21	E7010-P1	2-36
MIG WIRES/TIG RODS (GMAW/GTAW)			
OK AristoRod 13.08	G 46 0 C1 4Mo / G 4Mo / G 50 4 M21 4Mo	ER80S-D2	2-37
OK AristoRod 13.09	G 1M3 / G 2Mo / G 38 0 C1 2Mo / G 46 2 M21 2Mo / G MoSi	ER70S-A1 (ER80S-G)	2-38
OK AristoRod 13.12	G 55M 1CM3 / G CrMo1Si	ER80S-G	2-40
OK AristoRod 13.16	G 55 M13 1CM / G Z CrMo1Si	ER80S-B2	2-42
OK AristoRod 13.22	G 62 M 2C1M3 / G CrMo2Si	ER90S-G	2-44
OK AristoRod 13.26	G 42 0 C1 Z 3Ni1Cu / G 46 4 M21 Z 3Ni1Cu / G Z 3Ni1Cu	ER80S-G	2-45
OK AristoRod 55	G 55 4 M20 Mn3NiCrMo / G 55 4 M21 Mn3NiCrMo / G Mn3NiCrMo	ER100S-G	2-47
OK AristoRod 69	G 69 4 M20 Mn3Ni1CrMo / G 69 4 M21 Mn3Ni1CrMo / G Mn3Ni1CrMo	ER110S-G	2-49
OK AristoRod 79	G 79 4 M20 Mn4Ni2CrMo / G 79 4 M21 Mn4Ni2CrMo / G Mn4Ni2CrMo	ER120S-G	2-51
OK AristoRod 89	G 89 4 M20 Mn4Ni2CrMo / G 89 4 M21 Mn4Ni2CrMo / G Mn4Ni2CrMo	ER120S-G	2-52
OK Autrod 13.17	G 62A 2C1M	ER90S-B3	2-53
OK Autrod 13.23	G50 4 M21 Z3Ni / G55A 5 M21 SN2 / G55P 5U M21 SN2	ER80S-Ni1	2-54
OK Autrod 13.25	G 62 6 M21 Mn3Ni1Mo / G Mn-3Ni1Mo	ER100S-G	2-55

LOW ALLOY			
Product Name	EN/ISO	AWS	Page
OK Autrod 13.28	G 2Ni2 / G 46 6 M21 2Ni2	ER80S-Ni2	2-56
OK Autrod 13.29	G 69 4 M20 Mn3Ni1CrMo / G 69 4 M21 Mn3Ni1CrMo / G Mn3Ni1CrMo	ER100S-G	2-58
OK Autrod 13.37	G 55A 9C1M / G CrMo9	ER80S-B8	2-60
OK Tigrod 13.08	4M31 / W 50 3 Z 2Mo / W55A 3 4M31 / Z 2Mo	ER80S-D2	2-61
OK Tigrod 13.09	W 2Mo / W 46 2 2Mo / W 52 1M3 / W MoSi	ER70S-A1 (ER80S-G)	2-62
OK Tigrod 13.12	W 55 I1 1CM3 / W CrMo1Si	ER80S-G	2-64
OK Tigrod 13.16	W 55 1CM / Z CrMo1Si	ER80S-B2	2-65
OK Tigrod 13.17	W 62 2C1M / Z CrMo2Si	ER90S-B3	2-66
OK Tigrod 13.22	W 62 2C1M3 / W CrMo2Si	ER90S-G	2-67
OK Tigrod 13.23	W 46 5 Z3Ni1 / W Z3Ni1	ER80S-Ni1	2-68
OK Tigrod 13.26	W 46 6 Z 3Ni1Cu / W Z 3Ni1Cu	ER80S-G	2-69
OK Tigrod 13.28	W 2Ni2 / W 46 6 2Ni2	ER80S-Ni2	2-70
OK Tigrod 13.32	W 55 5CM / W CrMo5Si	ER80S-B6	2-71
OK Tigrod 13.37	W 55 9C1M / W CrMo9	ER80S-B8	2-72
OK Tigrod 13.38	W 62 I1 9C1MV / W CrMo91	ER90S-B91	2-73
OK Tigrod 55	Mn3NiCrMo / W 55 4 Mn3NiCrMo	ER100S-G	2-75
OK Tigrod B2 SC	W 55 I1 1CM / W Z CrMo1Si	ER80S-B2	2-76
OK Tigrod B3 SC	W 62 2C1M / W Z CrMo2Si	ER90S-B3	2-78
GAS-SHIELDED FLUX-CORED WIRES (FCAW/MCAW)			
Coreweld 46 LT H4	T 46 6 Z M M21 2 H5	E80C-G H4	2-80
Coreweld 55 LT H4	T 55 6 Z M21 2 H5	E90C-G H4	2-81
Coreweld 69 LT H4	T 69 6 Mn2NiMo M M21 2 H5 / T 76 6 T15 0M21A N4M2 U H5	E110C-G-H4	2-82
Coreweld 89	T 89 4 Z M M21 3 H5	E120C-G H4	2-83
Dual Shield 55	T 55 4 Z P M21 2 H5	E91T1-GM21 / E91T1-Ni1M21	2-84
Dual Shield 62	T 62 4 Mn1.5Ni P M21 2 H5	E101T1-G	2-85
Dual Shield 69	T 69 6 Z P M21 2 H5	E111T1-GM	2-86
Dual Shield 110C	T 69 6 Z P C1 2 H5	E111T1 GC H4	2-87
Dual Shield CrMo1	T CrMo1 P M 2 H5	E81T1-B2M	2-88
Dual Shield CrMo2	T CrMo2 P M 2 H5	E91T1-B3M	2-89
Dual Shield MoL	T MoL P M 2 H5	E81T1-A1M	2-90
Dual Shield Prime 81Ni1 H4	T 50 6 1Ni P C1 1 H5 / T556T1-1CA-N2-U-H5	E81T1-Ni1C H4	2-91
Dual Shield Prime 81Ni1M H4	T 50 6 1Ni P M21 1 H5 / T555T1-1M21A-N2-U-H5	E81T1-Ni1M H4	2-92

LOW ALLOY

Product Name	EN/ISO	AWS	Page
Filarc PZ6112	T 42 2 Z P C1 1 H5 / T 46 2 Z P M21 1 H5	E71T1-G H4 / E81T1-GM H8	2-93
Filarc PZ6114	T 46 5 P M21 1 H5 / T 55 5 T12-1 M21 A-U H5	E71T-1MJ H4	2-94
Filarc PZ6115	T 50 5 2Ni P M21 2 H5		2-95
Filarc PZ6116S	T 46 6 1.5Ni P C1 1 H5	E81T1-K2 C JH4	2-96
Filarc PZ6125	T 42 6 1Ni B M21 1 H5	E71T5-K6M H4	2-97
Filarc PZ6138	T 50 6 1Ni P M21 1 H5 / T 55 5 T1 M A N2 U H5	E81T1-Ni1M JH4	2-98
Filarc PZ6138SR	T 46 6 1Ni P M21 1 H5	E81T1-Ni1M J H4	2-99
Filarc PZ6138S SR	T 46 6 1Ni P C1 1 H5	E81T1-Ni1C J	2-100
Filarc PZ6222	T MoL P M 2 H5	E81T1-A1M H4	2-101
OK Tubrod 14.01	T 42 2 Z M M21 2 H5	E70C-GM	2-102
OK Tubrod 14.02	T 50 2 Z M M21 2 H5	E80C-G	2-103
OK Tubrod 14.03	T 69 4 Mn2NiMo M M21 2 H5	E110C-G / E111TG-K3	2-104
OK Tubrod 14.04	T 42 6 2Ni M M21 2 H5	E70C-G	2-105
OK Tubrod 14.05	T 42 4 Z M M21 2 H5	E70C-GM	2-106
OK Tubrod 15.09	T 69 4 2NiMo P M21 2 H5	E111T1-K3MJ-H4	2-107
OK Tubrod 15.11	T 50 6 2Ni P M21 2 H5	E81T1-Ni2M	2-108
OK Tubrod 15.17	T 46 3 1Ni P C1 2 H5 / T 46 4 1Ni P M21 2 H5	E81T1-Ni1MJ / E81T1-Ni1CJ H4	2-109
OK Tubrod 15.19	T 50 5 Z P M21 2 H5	E81T1-Ni1M	2-110
OK Tubrod 15.20		E81T5-B2M H4	2-111
OK Tubrod 15.22		E90T5-B3	2-112
OK Tubrod 15.24S	S 46 4 AB TZ (10.71) / S 46 5 FB T3Ni1 (10.62)	F7P8-EC-G (10.61) / F8A6-EC-G (10.62) / F8A6-EC-G (10.71)	2-113
OK Tubrod 15.27	T 69 5 Mn2.5Ni B M21 3 H5	E110T5-M21A6-G	2-114
OK Tubrod 15.27S	T 69 6 FB TZ H5 (OK Flux 10.62)	F11A8-EC-G (OK Flux 10.62)	2-115
Pipeweld 71T-1	T 42 3 P C1 1 H5 / T 46 4 P M21 1 H5	E71T-1C H4 / E71T-1M H8	2-116
Pipeweld 91T-1	T 55 4 Z P M21 2 H5	E91T1-G	2-117
Pipeweld 101T-1	T 62 4 Mn1Ni P M21 2 H5	E101T1-G	2-118
Pipeweld 111T-1	T 69 4 2NiMo P M21 2 H5	E111T1-K3MJ-H4	2-119
SELF-SHIELDED FLUX-CORED WIRES (FCAW)			
Coreshield 71T-8 OS	T42 4 1Ni Y NO 1	E71T8-Ni1 J H8	2-120
SUBARC (SAW)			
OK Autrod 12.24	S S Mo / S2Mo	EA2	2-121
OK Autrod 12.34	S S MnMo / S3Mo	EA4	2-122
OK Autrod 13.10 SC	S S CrMo1	EB2R	2-123

LOW ALLOY			
Product Name	EN/ISO	AWS	Page
OK Autrod 13.21	S2Ni1	ENi1	2-124
OK Autrod 13.24	S3Ni1Mo0,2	ENi6	2-125
OK Autrod 13.27	S2Ni2	ENi2	2-126
OK Autrod 13.33	S S CrMo5	EB6	2-127
OK Autrod 13.35	S S CrMo91	EB91	2-128
OK Autrod 13.36	S2Ni1Cu	EG	2-129
OK Autrod 13.40	(SUN2M2) / S3Ni1Mo / S3Ni1Mo	EF3	2-130
OK Autrod 13.43	(SUN4C1M3) / S3Ni2,5CrMo	EG	2-131
OK Autrod 13.49	S2Ni3	ENi3	2-132
OK Autrod 13.62	SZ3TiB	EG	2-133
OK Autrod 13.64	S2MoTiB	EA2TiB	2-134
OK Tubrod 15.24S	S 46 4 AB TZ (10.71) / S 46 5 FB T3Ni1 (10.62)	F7P8-EC-G (10.61) / F8A6-EC-G (10.62) / F8A6-EC-G (10.71)	2-135
OK Tubrod 15.27S	T 69 6 FB TZ H5 (OK Flux 10.62)	F11A8-EC-G (OK Flux 10.62)	2-136
OK Autrod B2 SC	S S CrMo1	EB2R	2-137
OK Autrod B3 SC	S S CrMo2	EB3R	2-138

MILD STEEL/LOW ALLOY SUBARC (SAW) FLUXES			
Product Name	EN/ISO	AWS	Page
OK Flux 10.61	S A FB 1 65 DC		3-3
OK Flux 10.62	S A FB 1 55 AC H5 / S A FB 1 55 AC H4 only BlockPac/moisture-protection		3-6
OK Flux 10.63	S A FB 1 55 AC H5		3-12
OK Flux 10.64	S A FB 1 54 DC H5		3-14
OK Flux 10.65	S A FB 1 65 AC H5 / S A FB 1 65 AC H4 only BlockPac/moisture protection		3-15
OK Flux 10.66	S A FB 1 55 AC H5		3-17
OK Flux 10.69	S A CS 4		3-19
OK Flux 10.70	S A AB 1 79 AC		3-20
OK Flux 10.71	S A AB 1 67 AC H5		3-22
OK Flux 10.72	S A AB 1 57 AC H5		3-27
OK Flux 10.74	S A AB 1 67 AC H5		3-30
OK Flux 10.77	S A AB 1 67 AC H5		3-33
OK Flux 10.78	S A AB 1 75 AC		3-36
OK Flux 10.79	S A AB 1 77 AC		3-37
OK Flux 10.81	S A AR 1 97 AC		3-38
OK Flux 10.83	S A AR 1 85 AC		3-41

STAINLESS STEEL

Product Name	EN/ISO	AWS	Page
STICK ELECTRODES (SMAW)			
OK 61.20	E 19 9 L R 1 1	E308L-16	4-9
OK 61.25	E 19 9 H B 2 2	E308H-15	4-10
OK 61.30	E 19 9 L R 1 2	E308L-17	4-11
OK 61.35	E 19 9 L B 2 2	E308L-15	4-12
OK 61.35 Cryo	E 19 9 L B 2 2	E308L-15	4-13
OK 61.50	E 19 9 H R 1 2	E308H-17	4-14
OK 61.80	E 19 9 Nb R 1 2	E347-17	4-15
OK 61.81	E 19 9 Nb R 3 2	E347-16	4-16
OK 61.85	E 19 9 Nb B 2 2	E347-15	4-17
OK 61.86	E 19 9 Nb R 1 2	E347-17	4-18
OK 63.20	E 19 12 3 L R 1 1	E316L-16	4-19
OK 63.30	E 19 12 3 L R 1 2	E316L-17	4-20
OK 63.34	E 19 12 3 L R 1 1	E316L-16	4-22
OK 63.35	E 19 12 3 L B 2 2	E316L-15	4-23
OK 63.41	E 19 12 3 L R 5 3	E316L-26	4-24
OK 63.80	E 19 12 3 Nb R 3 2	E318-17	4-25
OK 63.85	E 19 12 3 Nb B 4 2	E318-15	4-26
OK 64.30	E Z 19 13 4 N L R 3 2	E317L-17	4-27
OK 67.13	E 25 20 R 1 2	E310-16	4-28
OK 67.15	E 25 20 B 2 2	E310-15	4-29
OK 67.43	E 18 8 Mn R 1 2 / E Fe10	(E307-16)	4-30
OK 67.45	E 18 8 Mn B 2 2	(E307-15)	4-31
OK 67.50	E 22 9 3 N L R 3 2	E2209-17	4-32
OK 67.55	E 22 9 3 N L B 2 2	E2209-15	4-33
OK 67.60	E 23 12 L R 3 2	E309L-17	4-34
OK 67.70	E 23 12 2 L R 3 2	E309LMo-17	4-35
OK 67.75	E 23 12 L B 4 2	E309L-15	4-37
OK 68.15	E 13 B 4 2 / E Fe7	E410-15	4-38
OK 68.17	E 13 4 R 3 2 / E Fe7	E410NiMo-16	4-39
OK 68.25	E 13 4 B 4 2 / E Fe7	E410NiMo-15	4-40
OK 68.53	E 25 9 4 N L R 3 2	E2594-16	4-41
OK 68.55	E 25 9 4 N L B 4 2	E2594-15	4-42
OK 68.81	E 29 9 R 3 2 / E Fe11	E312-17	4-43
OK 68.82	E 29 9 R 1 2 / E Fe11	(E312-17)	4-44
OK 69.25	E 20 16 3 Mn N L B 4 2	E316LMn-15	4-45
OK 69.33	E 20 25 5 Cu N L R 3 2	E385-16	4-46

STAINLESS STEEL			
Product Name	EN/ISO	AWS	Page
OK 310Mo-L	E 25 22 2 N L R 1 2	(E310Mo-16)	4-47
Exaton 22.9.3.LB	E 22 9 3 N L B	E2209-15	4-48
Exaton 22.9.3.LR	E 22 9 3 N L R	E2209-17	4-49
Exaton 22.12.HTR	E Z 23 10 N R 12		4-50
Exaton 25.10.4.LB	E 25 9 4 N L B	E2594-15	4-51
Exaton 25.10.4.LR	E 25 9 4 N L R	E2594-16	4-52
Exaton 25.22.2.LMnB	E 25 22 2 N L B 12	(E310Mo-15)	4-53
Exaton 27.31.4.LCuR	E 27 31 4 Cu L R	E383-17	4-54
MIG WIRES/TIG RODS (GMAW/GTAW)			
OK Autrod 16.95	G 18 8 Mn	ER307 (mod)	4-55
OK Autrod 308H	G 19 9 H	ER308H	4-56
OK Autrod 308L	G 19 9 L	ER308L	4-57
OK Autrod 308LSi	G 19 9 L Si	ER308LSi	4-58
OK Autrod 309L	G 23 12 L	ER309L	4-60
OK Autrod 309LSi	G 23 12 L Si	ER309LSi	4-61
OK Autrod 309MoL	G 23 12 2 L	ER 23 12 2 L / ER309LMo (mod)	4-62
OK Autrod 309Si	G 22 12 H	ER309Si	4-63
OK Autrod 310	G 25 20	ER310	4-64
OK Autrod 312	G 29 9	ER312	4-65
OK Autrod 316L	G 19 12 3 L	ER316L	4-66
OK Autrod 316LMn	G 20 16 3 Mn N L	ER316LMn	4-68
OK Autrod 316LSi	G 19 12 3 L Si	ER316LSi	4-69
OK Autrod 317L	G 18 15 3 L	ER317L	4-71
OK Autrod 318Si	G 19 12 3 Nb Si	ER318 (mod)	4-72
OK Autrod 347	G 19 9 Nb	ER347	4-73
OK Autrod 347Si	G 19 9 Nb Si	ER347Si	4-75
OK Autrod 410NiMo	G 13 4		4-76
OK Autrod 430LNb	G 18 L Nb		4-77
OK Autrod 430LNbTi	G 18 L Nb Ti		4-78
OK Autrod 2209	G 22 9 3 N L	ER2209	4-79
OK Autrod 2504	G 25 4		4-81
OK Autrod 2509	G 25 9 4 N L	ER2594	4-82
OK Tigrod 16.95	W 18 8 Mn	ER307 (mod)	4-83
OK Tigrod 308H	W 19 9 H	ER308H	4-84
OK Tigrod 308L	W 19 9 L	ER308L	4-85
OK Tigrod 308LSi	W 19 9 L Si	ER308LSi	4-86
OK Tigrod 309L	W 23 12 L	ER309L	4-87

STAINLESS STEEL

Product Name	EN/ISO	AWS	Page
OK Tigrod 309LSi	W 23 12 L Si	ER309LSi	4-88
OK Tigrod 309MoL	W 23 12 2 L	ER 23 12 2 L / ER309LMo (mod)	4-89
OK Tigrod 310	W 25 20	ER310	4-90
OK Tigrod 312	W 29 9	ER312	4-91
OK Tigrod 316L	W 19 12 3 L	ER316L	4-92
OK Tigrod 316LSi	W 19 12 3 L Si	ER316LSi	4-93
OK Tigrod 317L	W18 15 3 L	ER317L	4-94
OK Tigrod 318Si	W 19 12 3 Nb Si	ER318 (mod)	4-95
OK Tigrod 347	W 19 9 Nb	ER347	4-96
OK Tigrod 347Si	W 19 9 Nb Si	ER347Si	4-97
OK Tigrod 410NiMo	W 13 4		4-98
OK Tigrod 430LNbTi	W 18 L Nb Ti		4-99
Exaton 19.9.L (GMAW)	G/W/P 19 9 L	ER308L	4-100
Exaton 19.9.LSi (GMAW)	G/W/P 19 9 L Si	ER308LSi	4-102
Exaton 19.12.3.LCRYO (GMAW)	G/W/P (19 12 3 L) / SS316L	ER316L	4-104
Exaton 19.12.3.LSiMo (GMAW)	G/W/P 19 12 3 L Si	316LSi	4-106
Exaton 19.13.4.L (GMAW)	G/W/P 19 13 4 L	ER317L	4-107
Exaton 20.25.5.LCu (GMAW)	G/W/P 20 25 5 Cu L	ER385	4-108
Exaton 22.8.3.L (GMAW)	2209 / G/W/P 22 9 3 N L	ER2209	4-110
Exaton 22.8.3.LSi (GMAW)	2209 / G/W/P 22 9 3 N L	ER2209	4-112
Exaton 22.12.HT (GMAW)	G/W/P 21 10 N		4-114
Exaton 24.13.LHF (GMAW)	G/W/P 23 12 L	ER309L	4-115
Exaton 24.13.LNb (GMAW)	G/W/P 23 12 Nb	ER309LNb	4-116
Exaton 25.10.4.L (GMAW)	G/W/P 25 9 4 N L	ER2594	4-117
Exaton 25.20.L (GMAW)	G/W/P Z 25 20 L	ER310 (mod)	4-119
Exaton 25.22.2.LMn (GMAW)	G/W/P 25 22 2 N L	ERG	4-120
Exaton 27.7.5.L (GMAW)	G/W/P Z 27 7 5 L		4-122
Exaton 24.31.4.LCu (GMAW)	G/W/P 27 31 4 Cu L	ER383	4-124
Exaton 29.8.2.L (GMAW)	G/W/P Z 29 8 2 L		4-126
Exaton AXT (GMAW)	G 18 8 Mn	ER(307) modified	4-128
Exaton SAFUREX (GMAW)	G/W/P Z 29 8 2 L		4-129
Exaton SX (GMAW)	G/W/P Z 18 13 Si Cu L		4-130
Exaton 19.9.L (GTAW)	W 19 9 L	ER308L	4-131
Exaton 19.9.LSi (GTAW)	W 19 9 L Si	ER308LSi	4-132
Exaton 19.12.3.LCRYO (GTAW)	SS316L / W (19 12 3 L)	ER316L	4-133
Exaton 19.12.3.LSiMo (GTAW)	W 19 12 3 L Si	316LSi	4-134
Exaton 19.13.4.L (GTAW)	W 19 13 4 L	ER317L	4-135

STAINLESS STEEL			
Product Name	EN/ISO	AWS	Page
Exaton 20.25.5.LCu (GTAW)	W 20 25 5 Cu L	ER385	4-136
Exaton 22.8.3.L (GTAW)	2209 / W 22 9 3 N L	ER2209	4-137
Exaton 22.8.3.LSi (GTAW)	2209 / W 22 9 3 N L	ER2209	4-138
Exaton 22.12.HT (GTAW)	W 21 10 N		4-139
Exaton 24.13.LHF (GTAW)	W 23 12 L	ER309L	4-140
Exaton 25.10.4.L (GTAW)	W 25 9 4 N L	ER2594	4-141
Exaton 25.20.L (GTAW)	W Z 25 20 L	ER310 (mod)	4-142
Exaton 25.22.2.LMn (GTAW)	W 25 22 2 N L	ERG	4-143
Exaton 27.7.5.L (GTAW)	W Z 27 7 5 L		4-144
Exaton 27.31.4.LCu (GTAW)	W 27 31 4 Cu L	ER383	4-145
Exaton 29.8.2.L (GTAW)	W Z 29 8 2 L		4-146
Exaton SAFUREX (GTAW)	W Z 29 8 2 L		4-147
Exaton SX (GTAW)	W Z 18 13 Si Cu L		4-148
GAS-SHIELDED FLUX-CORED WIRES (FCAW/MCAW)			
Arcaloy MC409Ti		EC409	4-150
Arcaloy MC439Ti		EC439	4-151
Filarc PZ6163	T Fe7		4-152
Filarc PZ6166	T 13 4 M M12 2 / T 13 4 M M13 2 / T Fe7		4-153
OK Tubrod 15.31	T 19 12 3 L M M12 2 / T 19 12 3 L M M13 2	EC316L	4-154
OK Tubrod 15.34	T 18 8 Mn M M12 2 / T 18 8 Mn M M13 2 / T 18 8 Mn M M21 2 / T Fe10		4-155
OK Tubrod 15.37	T 22 9 3 N L M M12 2 / T 22 9 3 N L M M13 2 / T Fe11	EC2209	4-156
Shield-Bright 308H	T 19 9 H P C1 2 / T 19 9 H P M21 2	E308HT1-1 / E308HT1-4	4-157
Shield-Bright 308L	T 19 9 L P C1 2 / T 19 9 L P M21 2	E308LT1-1 / E308LT1-4	4-158
Shield-Bright 308L X-tra	T 19 9 L R C1 3 / T 19 9 L R M21 3	E308LT0-1 / E308LT0-4	4-160
Shield-Bright 309L	T 23 12 L P C1 2 / T 23 12 L P M21 2	E309LT1-1 / E309LT1-4	4-161
Shield-Bright 309L X-tra	T 23 12 L R C1 3 / T 23 12 L R M21 3	E309LT0-1 / E309LT0-4	4-163
Shield-Bright 316L	T 19 12 3 L P C1 2 / T 19 12 3 L P M21 2	E316LT1-1 / E316LT1-4	4-166
Shield-Bright 316L X-tra	T 19 12 3 L R C1 3 / T 19 12 3 L R M21 3	E316LT0-1 / E316LT0-4	4-168
Shield-Bright 347	T 19 9 Nb P C1 2 / T 19 9 Nb P M21 2	E347T1-1 / E347T1-4	4-169
Shield-Bright 2209	T 22 9 3 N L P C1 2 / T 22 9 3 N L P M21 2	E2209T1-4, E2209T1-1	4-170
Shield-Bright 2594	T 25 9 4 N L P M21 2	E2594T1-4	4-172

STAINLESS STEEL

Product Name	EN/ISO	AWS	Page
SUBARC (SAW)			
OK Autrod 16.97	S 18 8 Mn		4-173
OK Autrod 308H	S 19 9 H	ER308H	4-174
OK Autrod 308L	S 19 9 L	ER308L	4-175
OK Autrod 309L	S 23 12 L	ER309L	4-176
OK Autrod 309MoL	S 23 12 2 L	ER 23 12 2 L / ER309LMo (mod)	4-177
OK Autrod 310	S 25 20	ER310	4-178
OK Autrod 316H	S 19 12 3 H	ER316H	4-179
OK Autrod 316L	S 19 12 3 L	ER316L	4-180
OK Autrod 316LMn	S 20 16 3 Mn N L	ER316LMn	4-181
OK Autrod 317L	S 18 15 3 L	ER317L	4-182
OK Autrod 318	S 19 12 3 Nb	ER318	4-183
OK Autrod 347	S 19 9 Nb	ER347	4-184
OK Autrod 410		ER410	4-185
OK Autrod 410NiMo	S 13 4		4-186
OK Autrod 430		ER430	4-187
Ok Autrod 2209	S 22 9 3 N L	ER2209	4-188
OK Autrod 2509	S 25 9 4 N L	ER2594	4-189
OK Flux 10.90	S A AF 2 55 53 MnNi DC		4-190
OK Flux 10.92	S A CS 2 57 53 DC		4-192
OK Flux 10.93	S A AF 2 56 54 DC		4-194
OK Flux 10.94	S A AF 2 56 64 DC		4-198
OK Flux 10.95	S A AF 2 56 44 Ni DC		4-200
OK Flux 10.99	S A FB 2 55 53 AC		4-201
Exaton 19.9.L (SAW)	S 19 9 L	ER308L	4-203
Exaton 19.12.3.L CRYO (SAW)	S (19 12 3 L) / SS316L	ER316L	4-204
Exaton 20.5.3.L (SAW)	S Z 20 5 3 L		4-205
Exaton 20.25.5.LCu (SAW)	S 20 25 5 Cu L	ER385	4-206
Exaton 22.8.3.L (SAW)	S 22 9 3 N L	ER2209	4-207
Exaton 22.12.HT (SAW)	S 21 10 N		4-208
Exaton 24.13.LHF (SAW)	S 23 12 L	ER309L	4-209
Exaton 24.13.LNb (SAW)	S 23 12 Nb	ER309LNb	4-210
Exaton 25.10.4.L (SAW)	S 25 9 4 N L	ER2594	4-211
Exaton 25.20.L (SAW)	S Z 25 20 L	ER310 (mod)	4-212
Exaton 25.22.2.LMn (SAW)	S 25 22 2 N L	ERG	4-213
Exaton 27.31.4.LCu (SAW)	S 27 31 4 Cu L	ER383	4-214

STAINLESS STEEL			
Product Name	EN/ISO	AWS	Page
Exaton 10SW	S A CS 2 Cr		4-215
Exaton 15W	S A AF 2		4-217
STRIP CLADDING (SAW/ESW)			
OK Band 308L	B 19 9 L	EQ308L	4-220
OK Band 309L	B 23 12 L	EQ309L	4-221
OK Band 309L ESW	B 22 11 L		4-222
OK Band 309LMo ESW	B 21 13 3 L	EQ309LMo (Mod)	4-223
OK Band 309LNb	B 23 12 L Nb		4-224
OK Band 309LNb ESW	B 22 12 L Nb		4-225
OK Band 316L	B 19 12 3 L	EQ316L	4-226
OK Band 347	B 19 9 Nb	EQ347	4-227
OK Flux 10.05	S A AAS 2B 56 34 DC		4-228
OK Flux 10.10	ES A FB 2B 56 44 DC		4-230
OK Flux 10.14	ES A FB 2B 56 44 DC		4-232
OK Flux 10.26	ES A FB 2B 54 91 NiMo DC		4-233
Exaton 19.9.L (ESW)	B 19 9 L	EQ308L	4-234
Exaton 19.9.LNb (ESW)	B 19 9 Nb	EQ347	4-235
Exaton 19.12.3.L (ESW)	B 19 12 3 L	EQ316L	4-236
Exaton 19.13.4.L (ESW)	B 19 13 4 L	EQ317L	4-237
Exaton 20.25.5.LCu (ESW)	B 20 25 5 Cu L	EQ385	4-238
Exaton 21.11.LNb (ESW)	B 22 11 L Nb	EQ"309LNb"	4-239
Exaton 21.13.3.L (ESW)	B 21 13 3 L	EQ(309LMo)	4-240
Exaton 22.8.3.L (ESW)	B 22 9 3 N L	EQ2209	4-241
Exaton 22.11.L (ESW)	B 22 11 L	EQ(309L)	4-242
Exaton 24.13.L (ESW)	B 23 12 L	EQ309L	4-243
Exaton 24.13.LNb (ESW)	B 23 12 Nb	EQ309LNb	4-244
Exaton 25.22.2.LMn (ESW)	B 25 22 2 N L	EQG	4-245
Exaton 29.8.2.L (ESW)	B Z 29 8 2 L		4-246
Exaton 10SW	S A CS 2 Cr		4-247
Exaton 31S	S A AB 2		4-249
Exaton 37S	ES A FB 2B		4-250
Exaton 47S	ES A FB 2B		4-251
Exaton 48S	ES A FB 2B		4-254
Exaton 49S	ES A FB 2B		4-255

NICKEL

Product Name	EN/ISO	AWS	Page
STICK ELECTRODES (SMAW)			
OK 92.55	E Ni 6620 (NiCr14Mo7Fe)	ENiCrMo-6	5-5
OK Ni-1	E Ni 2061 (NiTi3)	ENi-1	5-6
OK Ni-CI	E C Ni-CI 3	ENi-CI	5-7
OK NiFe-CI-A	E C NiFe-1 3	ENiFe-CI	5-8
OK NiCrFe-2	E Ni 6133 (NiCr16Fe12NbMo)	ENiCrFe-2	5-9
OK NiCrFe-3	E Ni 6182 (NiCr15Fe6Mn)	ENiCrFe-3	5-10
OK NiCrMo-3	E Ni 6625 (NiCr22Mo9Nb)	ENiCrMo-3	5-11
OK NiCrMo-5	E Z Ni2		5-12
OK NiCu-1	E C NiCu 1		5-13
OK NiCu-7	E Ni 4060 (NiCu30Mn3Ti)	ENiCu-7	5-14
Exaton Ni59	E Ni 6059 (NiCr23Mo16)	ENiCrMo-13	5-15
Exaton Ni60	E Ni 6625 (NiCr22Mo9Nb)	ENiCrMo-3	5-16
MIG WIRES/TIG RODS (GMAW/GTAW)			
OK Autrod Ni-1	S Ni 2061 (NiTi3)	ERNi-1	5-17
OK Autrod NiCrMo-3	S Ni 6625 / S Ni 6625 (NiCr22Mo9Nb)	ERNiCrMo-3 / ERNiCrMo-3	5-18
OK Autrod NiCrMo-4	S Ni 6276 (NiCr15Mo16Fe6W4) / S Ni 6276 (NiCr15Mo16Fe6W4)	ERNiCrMo-4 / ERNiCrMo-4	5-20
OK Autrod NiCu-7	S Ni 4060 (NiCu30Mn3Ti)	ERNiCu-7	5-21
OK Tigrod Ni-1	S Ni 2061 (NiTi3)	ERNi-1	5-22
OK Tigrod NiCrMo-3	S Ni 6625	ERNiCrMo-3	5-23
OK Tigrod NiCrMo-4	S Ni 6276 (NiCr15Mo16Fe6W4)	ERNiCrMo-4	5-24
OK Tigrod NiCu-7	S Ni 4060 (NiCu30Mn3Ti)	ERNiCu-7	5-25
Exaton Ni41Cu (GMAW)	S Ni 8065 (NiFe30Cr21Mo3)	ERNiFeCr-1	5-26
Exaton Ni53 (GMAW)	S Ni 6617 (NiCr22Co12Mo9)	ERNiCrCoMo-1	5-27
Exaton Ni54 (GMAW)	S Ni 6022 (NiCr21Mo13Fe4W3)	ERNiCrMo-10	5-28
Exaton Ni55 (GMAW)	S Ni6686 (NiCr21Mo16W4)	ERNiCrMo-14	5-29
Exaton Ni56 (GMAW)	S Ni 6276 (NiCr15Mo16Fe6W4)	ERNiCrMo-4	5-30
Exaton Ni59 (GMAW)	S Ni 6059 (NiCr23Mo16)	ERNiCrMo-13	5-31
Exaton Ni60 (GMAW)	S Ni 6625 (NiCr22Mo9Nb)	ERNiCrMo-3	5-32
Exaton Ni60 Overlay	S Ni 6625 (NiCr22Mo9Nb)	ERNiCrMo-3	5-34
Exaton Ni72HP (GMAW)	S Ni 6082 (NiCr20Mn3Nb)	ERNiCr-3	5-35
Exaton Ni41Cu (GTAW)	S Ni 8065 (NiFe30Cr21Mo3)	ERNiFeCr-1	5-36
Exaton Ni53 (GTAW)	S Ni 6617 (NiCr22Co12Mo9)	ERNiCrCoMo-1	5-37
Exaton Ni54 (GTAW)	S Ni 6022 (NiCr21Mo13Fe4W3)	ERNiCrMo-10	5-38
Exaton Ni55 (GTAW)	S Ni 6686 (NiCr21Mo16W4)	ERNiCrMo-14	5-39
Exaton Ni56 (GTAW)	S Ni 6276 (NiCr15Mo16Fe6W4)	ERNiCrMo-4	5-40

NICKEL			
Product Name	EN/ISO	AWS	Page
Exaton Ni59 (GTAW)	S Ni 6059 (NiCr23Mo16)	ERNiCrMo-13	5-41
Exaton Ni60 (GTAW)	S Ni 6625 (NiCr22Mo9Nb)	ERNiCrMo-3	5-42
Exaton Ni72HP (GTAW)	S Ni 6082 (NiCr20Mn3Nb)	ERNiCr-3	5-43
GAS-SHIELDED FLUX-CORED WIRES (FCAW/MCAW)			
Cryo-Shield Ni9			5-44
Shield-Bright NiCrMo-3	T Ni 6625 P M21 2	ENiCrMo3T1-4	5-45
SUBARC (SAW)			
OK Autrod NiCrMo-3	S Ni 6625 / S Ni 6625 (NiCr22Mo9Nb)	ERNiCrMo-3 / ERNiCrMo-3	5-46
OK Autrod NiCrMo-4	S Ni 6276 (NiCr15Mo16Fe6W4) / S Ni 6276 (NiCr15Mo16Fe6W4)	ERNiCrMo-4 / ERNiCrMo-4	5-47
OK Flux 10.16	S A FB 2 55 43 DC		5-48
OK Flux 10.17	S A FB 2B 57 24 DC		5-49
OK Flux 10.90	S A AF 2 55 53 MnNi DC		5-50
OK Flux 10.93	S A AF 2 56 54 DC		5-52
OK Flux 10.99	S A FB 2 55 53 AC		5-56
Exaton Ni41Cu (SAW)	S Ni 8065	ERNiFeCr-1	5-58
Exaton Ni56 (SAW)	S Ni 6276 (NiCr15Mo16Fe6W4)	ERNiCrMo-4	5-59
Exaton Ni59 (SAW)	S Ni 6059 (NiCr23Mo16)	ERNiCrMo-13	5-60
Exaton Ni60 (SAW)	S Ni 6625 (NiCr22Mo9Nb)	ERNiCrMo-3	5-61
Exaton Ni72HP (SAW)	S Ni 6082 (NiCr20Mn3Nb)	ERNiCr-3	5-62
Exaton 15W	S A AF 2		5-63
Exaton 50SW	S A AF 2		5-66
STRIP CLADDING (SAW/ESW)			
OK Band NiCrMo3	B Ni 6625 (NiCr22Mo9Nb)	EQNiCrMo-3	5-67
OK Band NiFeCr1	B Ni 8065 (NiFe30Cr21Mo3)	EQNiFeCr-1	5-68
OK Flux 10.11	ES A FB 2B 56 44 DC		5-69
OK Flux 10.16	S A FB 2 55 43 DC		5-70
OK Flux 10.17	S A FB 2B 57 24 DC		5-71
Exaton Ni41Cu (ESW)	B Ni 8065	EQNiFeCr-1	5-72
Exaton Ni56 (ESW)	B Ni6276 (NiCr15Mo16Fe6W4)	EQNiCrMo-4	5-73
Exaton Ni60 (ESW)	B Ni 6625 (NiCr22Mo9Nb)	EQNiCrMo-3	5-74
Exaton Ni72HP (ESW)	B Ni 6082	EQNiCr-3	5-75
Exaton 50SW	S A AF 2		5-76
Exaton 69S	ES A FB 2B		5-77
Exaton 79S	ES A FB 2B DC		5-78

ALUMINIUM

Product Name	EN/ISO	AWS	Page
STICK ELECTRODES (SMAW)			
OK AlMn1	AlMn1		6-7
OK AlSi5	AlSi5		6-8
OK AlSi12	AlSi12		6-9
MIG WIRES/TIG RODS (GMAW/GTAW)			
OK Autrod 1070	S Al 1070 (Al99,7)		6-10
OK Autrod 1100	S Al 1100 (Al99,0Cu)	ER1100	6-11
OK Autrod 1450	S Al 1450 (Al99,5Ti)		6-12
OK Autrod 4043	S Al 4043 (AlSi5)	ER4043	6-13
OK Autrod 4047	S Al 4047 (AlSi12)	ER4047	6-14
OK Autrod 5087	S Al 5087 (AlMg4,5MnZr)	ER5087	6-15
OK Autrod 5183	S Al 5183 (AlMg4,5Mn0,7(A))	ER5183	6-16
OK Autrod 5356	S Al 5356 (AlMg5Cr(A))	ER5356	6-17
OK Autrod 5554	S Al 5554 (AlMg2,7Mn)	ER5554	6-18
OK Autrod 5556	S Al 5556A (AlMg5Mn1Ti)	ER5556	6-19
OK Tigrod 1070	S Al 1070 (Al99,7)		6-20
OK Tigrod 1100	S Al 1100 (Al99,0Cu)	R1100	6-21
OK Tigrod 1450	S Al 1450 (Al99,5Ti)		6-22
OK Tigrod 4043	S Al 4043 (AlSi5)	R4043	6-23
OK Tigrod 4047	S Al 4047 (AlSi12)	R4047	6-24
OK Tigrod 5087	S Al 5087 (AlMg4,5MnZr)	R5087	6-25
OK Tigrod 5183	S Al 5183 (AlMg4,5Mn0,7(A))	R5183	6-26
OK Tigrod 5356	S Al 5356 (AlMg5Cr(A))	R5356	6-27
OK Tigrod 5554	S Al 5554 (AlMg2,7Mn)	R5554	6-28

COPPER

Product Name	EN/ISO	AWS	Page
STICK ELECTRODES (SMAW)			
OK 94.25	E Cu Z (CuSn7)		7-5
OK 94.35	E Cu 7158 (CuNi30Mn2FeTi)	ECuNi	7-6
MIG WIRES/TIG RODS (GMAW/GTAW)			
OK Autrod 19.12	CuSn1	ERCu	7-7
OK Autrod 19.30	CuSi3Mn1	ERCuSi-A	7-8
OK Autrod 19.40	S Cu 6100 (CuAl7)	ERCuAl-A1	7-9
OK Autrod 19.41	CuAl8Ni2Fe2Mn2		7-10
OK Autrod 19.46	CuMn13Al8Fe3Ni2	ERCuMnNiAl	7-11
OK Autrod 19.49	S Cu 7158 (CuNi30)	ERCuNi	7-12

COPPER			
Product Name	EN/ISO	AWS	Page
OK Autrod CuSi Laser	Cu 6560 (CuSi3Mn1)	ERCuSi-A	7-13
OK Tigrod 19.12	CuSn1	ERCu	7-14
OK Tigrod 19.30	CuSi3Mn1	ERCuSi-A	7-15
OK Tigrod 19.40	CuAl7	ERCuAl-A1	7-16
OK Tigrod 19.41			7-17
OK Tigrod 19.49	S Cu 7158 (CuNi30Mn1FeTi)	ERCuNi	7-18

HARDFACING			
Product Name	EN/ISO	AWS	Page
STICK ELECTRODES (SMAW)			
OK 13Mn	E Fe9		8-9
OK 14MnNi	E Z Fe9		8-10
OK Tooltrode 50	E Z Fe3		8-11
OK Tooltrode 60	E Fe4		8-12
OK Weartrode 30	E Z Fe1		8-13
OK Weartrode 30 HD	E Fe1		8-14
OK Weartrode 35	E Fe1		8-15
OK Weartrode 40	E Z Fe2		8-16
OK Weartrode 45	E Z Fe3		8-17
OK Weartrode 50	E Z Fe2		8-18
OK Weartrode 50 T	E Z Fe8		8-19
OK Weartrode 55	E Z Fe3		8-20
OK Weartrode 55 HD	E Z Fe6		8-21
OK Weartrode 60	E Z Fe2		8-22
OK Weartrode 60 T	E Z Fe14		8-23
OK Weartrode 62			8-24
OK Weartrode 65 T	E Fe16		8-25
MIG WIRES/TIG RODS (GMAW/GTAW)			
OK Autrodur 38 G M	Fe2		8-26
OK Autrodur 56 G M	Fe8		8-27
OK Autrodur 58 G M	ZFe8		8-28
GAS-SHIELDED FLUX-CORED WIRES (FCAW/MCAW)			
OK Tubrodur 13Cr G	T Z Fe7		8-29
OK Tubrodur 35 G M	T Fe1		8-30
OK Tubrodur 53 G M	T Fe3		8-31
OK Tubrodur 60 G M	T Z Fe2		8-32

HARDFACING

Product Name	EN/ISO	AWS	Page
SELF-SHIELDED FLUX-CORED WIRES (FCAW)			
OK Tubrodur 13Mn O/G	T Fe9		8-33
OK Tubrodur 15CrMn O/G	T Fe9		8-34
OK Tubrodur 30 O M	T Z Fe1		8-35
OK Tubrodur 35 O M	T Z Fe3		8-36
OK Tubrodur 40 O M	T Z Fe2		8-37
OK Tubrodur 55 O A	T Z Fe14		8-38
OK Tubrodur 58 O/G M	T Fe6		8-39
OK Tubrodur 200 O D	T Fe10		8-40
SUBARC (SAW)			
OK Tubrodur 12Cr S	T Fe7		8-41
OK Tubrodur 13Cr S	T Fe7		8-42
OK Tubrodur 23 Cr S	T Fe7		8-43
OK Tubrodur 35 S M	T Fe1		8-44
OK Tubrodur 40 S M	T Z Fe1		8-45
OK Tubrodur 58 S M	T Fe6		8-46
OK Flux 10.33	S A FB 2 56 53 DC		8-47
OK Flux 10.96	S A GS 3 Cr3 DC		8-48
OK Flux 10.97	S A AB 3 Cr1 Mn2 DC		8-49
STRIP CLADDING (SAW/ESW)			
OK Band 11.84			8-50
OK Band 430	B 17		8-51
OK Flux 10.07	S A GS 3 Ni4 Mo1 DC		8-52
OK Flux 10.10	ES A FB 2B 56 44 DC		8-53

REPAIR & MAINTENANCE

Product Name	EN/ISO	AWS	Page
ALUMINIUM STICK ELECTRODES (SMAW)			
OK AlMn1	AlMn1		9-3
OK AlSi5	AlSi5		9-4
OK AlSi12	AlSi12		9-5
OTHER			
OK GPC			9-6
OK Ni-CI	E C Ni-CI 3	ENi-CI	9-7
OK NiFe-CI	E C NiFe-1 3	ENiFe-CI	9-8
OK NiFe-CI-A	E C NiFe-CI-A 1	ENiFe-CI-A	9-9
OK NiCu 1	E C NiCu 1		9-10
Nicore 55			9-11



Mild Steel / Low Alloy

Welding of Mild and Low-Alloy Steels	1-4
STICK ELECTRODES.....	1-6
OK 43.32.....	1-6
OK 46.00.....	1-7
OK 46.16.....	1-8
OK 46.30.....	1-9
OK 46.44.....	1-10
OK 48.00.....	1-11
OK 48.04.....	1-13
OK 48.10 RMn	1-14
OK 48.50.....	1-15
OK 48.60.....	1-16
OK 50.40.....	1-17
OK 53.05.....	1-18
OK 53.16 Spezial	1-19
OK 53.68.....	1-20
OK 53.70.....	1-21
OK 55.00.....	1-22
OK Femax 33.60	1-24
OK Femax 33.80	1-25
OK Femax 38.65	1-26
OK Femax 38.95	1-27
OK Femax 39.50	1-28
OK GoldRox.....	1-29
Pipeweld 6010 Plus.....	1-30
MIG WIRES/TIG RODS (GMAW/GTAW)	1-31
Filarc PZ6500	1-31
OK AristoRod 12.50	1-32
OK AristoRod 12.57	1-34
OK AristoRod 12.62	1-36
OK AristoRod 12.63	1-37
OK AristoRod 38 Zn	1-39
OK Autrod 12.51	1-41
OK Autrod 12.56	1-43
OK Autrod 12.58	1-44
OK Autrod 12.64	1-46
OK Autrod 12.64 HP	1-48
OK Autrod 12.66	1-50
OK Autrod 42 LSW.....	1-51
Pipeweld 70S-6.....	1-52
Purus 42.....	1-53
Purus 42 CF.....	1-55
Purus 46.....	1-57
Purus 46 CF	1-59
Weld G3Si1	1-61
OK Gasrod 98.70.....	1-62
OK Tigrod 12.60	1-63
OK Tigrod 12.61	1-64
OK Tigrod 12.62.....	1-65
OK Tigrod 12.64.....	1-66



GAS-SHIELDED FLUX-CORED WIRES (FCAW/MCAW)	1-67
Filarc PZ6111	1-67
Filarc PZ6111HS	1-68
Filarc PZ6113	1-69
Filarc PZ6113S	1-71
Coreweld 46 LS	1-72
Coreweld 46 RMn	1-73
Dual Shield Prime 71 LT H4	1-74
Dual Shield 46M RMn	1-76
OK E71T-1	1-77
OK Tubrod 14.00S	1-78
OK Tubrod 14.10	1-79
OK Tubrod 14.11	1-80
OK Tubrod 14.12	1-81
OK Tubrod 14.13	1-82
OK Tubrod 15.00	1-83
OK Tubrod 15.00S	1-84
OK Tubrod 15.14	1-85
SELF-SHIELDED FLUX-CORED WIRES (FCAW)	1-86
Coreshield 8	1-86
Coreshield 15	1-87
SUBARC (SAW)	1-88
OK Autrod 12.10	1-88
OK Autrod 12.20	1-89
OK Autrod 12.22	1-90
OK Autrod 12.32	1-91
OK Autrod 12.40	1-92
OK Tubrod 14.00S	1-93
OK Tubrod 15.00S	1-94

1. Materials

This section contains information on selecting the appropriate welding consumable for unalloyed steels and fine-grained steels with minimum yield strengths up to 485 MPa.

2. Welding and Heat Treatment

2.1 General

The general rules of engineering apply; during processing, take greater care as the yield strength and material thickness increase. When welding begins, the weld joints must be dry and free of slag, rust, scale and contaminants. For better resistance to cold cracking, welding consumables that generate a low hydrogen content in the weld metal should be used for steels with yield strengths > 355 MPa; for example, the use of rutile or rutile cellulose-coated electrodes is not suitable.

High-quality basic welding consumables meet all requirements. These should be stored in a dry place and, if necessary, dried again before use. Using stick electrodes in vacuum packaging (VacPac™) can eliminate these time and cost expenditures.

For severe environments such as acids and ammonia, special attention must be paid to the chemical composition and the mechanical and corrosion resistant properties of the grade of electrode selected. ESAB consultants are available to assist in selecting the optimal solution for your needs.

2.2 Preheating, Interpass Temperature and Post-Weld Heat Treatment

The preheating must be selected with consideration for the carbon equivalent, metal thickness, cross-sectional area and heat input. Preheating is primarily used to avoid brittle hardening zones in the HAZ. For low temperature applications even with relatively low material thickness (from approx. 12 mm) preheating to approx. 80 - 150°C is recommended.

In many standards, the minimum preheating temperature is defined to avoid cold cracking, however, this does not guarantee sufficient toughness of the heat-affected zone (HAZ).

On the other hand, maintaining the maximum interpass temperature serves to prevent grain growth in the HAZ. Coarse grain formation is associated with a decrease in toughness and a slight increase in hardness. The interpass temperature is usually at least 50°C above the preheating temperature, but max. 250°C.

Very low heat input (e.g. short, thin tacks on thick sheets without preheating) leads to fast cooling and thus hardening and the risk of cracking. If welding is "too hot" (e.g. very wide weave beads in the vertically up position), this can lead to coarse grain formation and a decrease in toughness.

For the steels listed below, stress relieving is usually the only heat treatment that can be considered. Before a welding consumable is selected, the resulting impact on the weld metal properties (decrease in strength and toughness, if applicable) must be taken into consideration.

2.3 Notes on welding

- Welding consumables whose strength is not necessarily high compared to the parent material should be selected.
- Tack and root welding is often performed with “softer” welding consumables to avoid cracking.
- If the demands placed on the Charpy V-notch properties are higher, the multi-run technique should be used.
- The weld build-up should be started at the weld edges; the subsequent bead has a positive effect on the heat-affected zone.
- Smaller electrode diameters must be used when welding vertical seams.
- If the component temperature is below +5°C, preheating is always required prior to welding.
- If tack welds form part of the weld joint, the welding consumables used must be adapted to the parent material. These welds must be checked for cracks before being welded over.
- The arc must be ignited on the component in the weld groove.

For further information, refer to:

- Steel-Iron Material Data Sheet SEW 088: Weldable fine-grain steels and SEW 088 supplements, SEW 063, SEW 086, SEW 090
- DVS leaflet 0916: Metal gas-shielded arc welding of fine-grain structural steels
- DVS leaflet 0918: Submerged-arc welding of fine-grain structural steels
- EN 1011: Welding – Recommendations for welding of metallic materials
 - Part 1: General instructions for Arc welding
 - Part 2: Arc welding of Ferritic steels

OK 43.32



Easy-to-weld rutile type electrode for welding in the flat position. The good flowing properties of the weld metal give a good finish of the weld beads both on butt and fillet welds. Good slag detachability. The stable arc, also on low welding currents, makes the electrode very suitable for sheet metal welding.

Specifications

Classifications	SFA/AWS A5.1 : E6013 EN ISO 2560-A : E 42 0 RR 12
Approvals	ABS : 2 BV : 2 CE : EN 13479 DB : 10.039.36 DNV : 2 LR : 2 UKCA : EN 13479 VdTÜV : 00621

Approvals are based on factory location. Please contact ESAB for more information.

Welding Current	AC, DC+-
Alloy Type	Carbon Manganese
Coating Type	Rutile thick covering
Min AC OCV	50V

Typical Tensile Properties

Condition	Yield Strength	Tensile Strength	Elongation
ISO			
As Welded	460 MPa	520 MPa	27 %

Typical Charpy V-Notch Properties

Condition	Testing Temperature	Impact Value
ISO		
As Welded	0 °C	60 J

Typical Weld Metal Analysis %

C	Mn	Si
0.08	0.5	0.4

Deposition Data

Diameter	Current	Voltage	Efficiency (%)	Fusion time per electrode at 90% I max	Deposition Rate
2.0 x 300 mm	50-80 A	23 V	54 %	36 sec	0.6 kg/h
2.5 x 350 mm	50-110 A	25 V	54 %	46 sec	0.9 kg/h
3.2 x 350 mm	80-150 A	26 V	57 %	57 sec	1.3 kg/h
3.2 x 450 mm	80-140 A	26 V	54 %	74 sec	1.3 kg/h
4.0 x 350 mm	120-210 A	25 V	52 %	63 sec	1.6 kg/h
4.0 x 450 mm	120-210 A	27 V	54 %	76 sec	1.9 kg/h
5.0 x 450 mm	170-290 A	26 V	56 %	87 sec	2.5 kg/h
6.0 x 450 mm	230-370 A	31 V	52 %	105 sec	2.8 kg/h

OK 46.00



OK 46.00 is an excellent performing, easy to use, rutile electrode and is relatively insensitive to rust or other surface impurities. It deposits smooth weld beads in all positions including vertical down with self releasing slag. Good striking and restriking properties making it ideal for short welds, root runs and tacking, also useful for bridging gaps.

Specifications	
Classifications	SFA/AWS A5.1 : E6013 EN ISO 2560-A : E 38 0 RC 11
Approvals	ABS : 2 BV : 2 CE : EN 13479 DB : 10.039.05 DNV : 2 LR : 2 UKCA : EN 13479 VdTÜV : 00623

Approvals are based on factory location. Please contact ESAB for more information.

Welding Current	AC, DC+-
Alloy Type	Carbon Manganese
Coating Type	Rutile-cellulosic covering
Min AC OCV	50

Typical Tensile Properties			
Condition	Yield Strength	Tensile Strength	Elongation
ISO			
As Welded	400 MPa	510 MPa	28 %

Typical Charpy V-Notch Properties		
Condition	Testing Temperature	Impact Value
ISO		
As Welded	0 °C	70 J

Typical Weld Metal Analysis %		
C	Mn	Si
0.08	0.42	0.30

Deposition Data					
Diameter	Current	Voltage	Efficiency (%)	Fusion time per electrode at 90% I max	Deposition Rate
1.6 x 300 mm	30-60 A	26 V	63 %	36 sec	0.38 kg/h
2.0 x 300 mm	50-80 A	25 V	60 %	38 sec	0.55 kg/h
2.5 x 350 mm	60-100 A	22 V	65 %	50 sec	0.8 kg/h
3.2 x 350 mm	80-150 A	22 V	65 %	57 sec	1.3 kg/h
4.0 x 350 mm	100-230 A	22 V	60 %	65 sec	1.6 kg/h
4.0 x 450 mm	100-230 A	27 V	69 %	71 sec	1.77 kg/h
5.0 x 350 mm	150-290 A	24 V	60 %	87 sec	2.3 kg/h
5.0 x 450 mm	150-290 A	24 V	60 %	114 sec	2.3 kg/h

OK 46.16



All-round, all-positional rutile electrode for thin and medium thick plates. Good striking and restriking properties. A relatively thick coating makes the electrode weld quietly with little spatter.

Specifications

Classifications	SFA/AWS A5.1 : E7014 EN ISO 2560-A : E 38 0 RC 11
Approvals	ABS : 2 BV : 2 CE : EN 13479 DB : 10.039.37 DNV : 2 UKCA : EN 13479 VdTÜV : 02528

Approvals are based on factory location. Please contact ESAB for more information.

Welding Current	AC, DC+-
Alloy Type	Carbon Manganese
Coating Type	Rutile-cellulosic covering
Min AC OCV	50V

Typical Tensile Properties

Condition	Yield Strength	Tensile Strength	Elongation
ISO			
As Welded	440 MPa	510 MPa	26 %

Typical Charpy V-Notch Properties

Condition	Testing Temperature	Impact Value
ISO		
As Welded	0 °C	60 J

Typical Weld Metal Analysis %

C	Mn	Si
0.09	0.5	0.4

Deposition Data

Diameter	Current	Voltage	Efficiency (%)	Fusion time per electrode at 90% I max	Deposition Rate
2.0 x 300 mm	50-70 A	24 V	57 %	40 sec	0.54 kg/h
2.5 x 350 mm	60-100 A	25 V	60 %	49 sec	0.9 kg/h
3.2 x 350 mm	80-150 A	23 V	58 %	59 sec	1.3 kg/h
4.0 x 350 mm	100-200 A	24 V	59 %	65 sec	1.8 kg/h

OK 46.30



All-round, general purpose rutile electrode for thin and medium thick plates. Good striking and restriking properties, suitable for tack welding. Useful for bridging gaps.

Specifications	
Classifications	SFA/AWS A5.1 : E6013 EN ISO 2560-A : E 38 0 R 12
Approvals	CE : EN 13479 UKCA : EN 13479

Approvals are based on factory location. Please contact ESAB for more information.

Welding Current	AC, DC+(-)
Alloy Type	Carbon Manganese
Coating Type	Rutile covering
Min AC OCV	50V

Typical Tensile Properties			
Condition	Yield Strength	Tensile Strength	Elongation
ISO			
As Welded	440 MPa	515 MPa	26 %

Typical Charpy V-Notch Properties		
Condition	Testing Temperature	Impact Value
ISO		
As Welded	0 °C	70 J

Typical Weld Metal Analysis %		
C	Mn	Si
0.07	0.49	0.31

Deposition Data					
Diameter	Current	Voltage	Efficiency (%)	Fusion time per electrode at 90% I max	Deposition Rate
2.5 x 350 mm	70-100 A	24 V	60 %	58 sec	0.7 kg/h
3.2 x 350 mm	100-140 A	23 V	61 %	60 sec	1.1 kg/h
4.0 x 450 mm	120-170 A	21 V	64 %	96 sec	1.4 kg/h
5.0 x 450 mm	160-250 A	21 V	66 %	105 sec	2.0 kg/h

OK 46.44



Rutile cellulosic electrode particularly suitable for vertical-down welding. Good ability to bridge gaps.

Specifications

Classifications	SFA/AWS A5.1 : E6013 EN ISO 2560-A : E 38 0 RC 11
Approvals	ABS : 2 BV : 2 CE : EN 13479 DB : 10.039.01 DNV : 2 LR : 2 UKCA : EN 13479 VdTÜV : 00674

Approvals are based on factory location. Please contact ESAB for more information.

Welding Current	AC, DC+-
Alloy Type	Carbon Manganese
Coating Type	Rutile-cellulosic covering
Min AC OCV	42

Typical Tensile Properties

Condition	Yield Strength	Tensile Strength	Elongation
ISO			
As Welded	460 MPa	530 MPa	26 %

Typical Charpy V-Notch Properties

Condition	Testing Temperature	Impact Value
ISO		
As Welded	0 °C	60 J

Typical Weld Metal Analysis %

C	Mn	Si
0.07	0.5	0.4

Deposition Data

Diameter	Current	Voltage	Efficiency (%)	Fusion time per electrode at 90% I max	Deposition Rate
2.5 x 350 mm	70-100 A	26 V	61 %	58 sec	0.78 kg/h
3.2 x 350 mm	90-150 A	30 V	51 %	52 sec	1.0 kg/h
4.0 x 350 mm	110-200 A	22 V	62 %	62 sec	1.58 kg/h

OK 48.00



A reliable, general purpose electrode for manual metal arc welding of carbon steels, carbon manganese steels and fine-grained carbon manganese steels with elevated yield strength. OK 48.00 deposits a tough, crack-resistant weld metal. The coating is of the low moisture absorption type. High welding speed in the vertical-up position. OK 48.00 is insensitive to the composition of the base material within fairly wide limits. The electrode can be used for welding structures where difficult stress conditions cannot be avoided. Tested according to NACE TM0177 and TM0284. Diffusible Hydrogen tested in various conditions show values below 3 ml/100g.

Specifications	
Classifications	SFA/AWS A5.1 : E7018 H4 R EN ISO 2560-A : E 42 4 B 42 H5
Approvals	ABS : 3Y H5 BV : 3Y H5 CE : EN 13479 DB : 10.039.12 DNV-GL : 3 YH5 LR : 3Y H5 PRS : 3Y H5 RINA : 3Y H5 UKCA : EN 13479 VdTÜV : 00690

Approvals are based on factory location. Please contact ESAB for more information.

Welding Current	DC+(-)
Diffusible Hydrogen	< 4.0 ml/100g
Alloy Type	Carbon Manganese
Coating Type	Basic covering

Typical Tensile Properties			
Condition	Yield Strength	Tensile Strength	Elongation
ISO			
As Welded	475 MPa	565 MPa	29 %

Typical Charpy V-Notch Properties		
Condition	Testing Temperature	Impact Value
AWS		
As Welded	-30 °C	130 J
ISO		
As Welded	-40 °C	115 J

Typical Weld Metal Analysis %		
C	Mn	Si
0.06	1.1	0.5

Deposition Data					
Diameter	Current	Voltage	Efficiency (%)	Fusion time per electrode at 90° I max	Deposition Rate
1.6 x 300 mm	30-55 A	24 V	59 %	50 sec	0.38 kg/h
2.0 x 300 mm	55-90 A	22 V	65 %	45 sec	0.63 kg/h
2.5 x 350 mm	70-110 A	24 V	67 %	57 sec	0.96 kg/h
3.2 x 350 mm	90-140 A	23 V	70 %	68 sec	1.24 kg/h

OK 48.00

Deposition Data

Diameter	Current	Voltage	Efficiency (%)	Fusion time per electrode at 90% I max	Deposition Rate
3.2 x 450 mm	90-140 A	23 V	73 %	85 sec	1.33 kg/h
4.0 x 350 mm	120-190 A	24 V	70 %	75 sec	1.63 kg/h
4.0 x 450 mm	120-190 A	24 V	71 %	92 sec	1.76 kg/h
5.0 x 450 mm	190-260 A	24 V	75 %	99 sec	2.61 kg/h
6.0 x 450 mm	220-340 A	26 V	80 %	97 sec	3.88 kg/h
7.0 x 450 mm	280-410 A	27 V	79 %	104 sec	4.83 kg/h

OK 48.04



AC/DC, general purpose, LMA electrode for welding mild and low alloy steels. It has very good welding properties and deposits a high quality weld metal with good mechanical properties. The electrode can be used for welding restrained structures where high stresses cannot be avoided.

Specifications	
Classifications	SFA/AWS A5.1 : E7018 EN ISO 2560-A : E 42 4 B 32 H5
Approvals	ABS : E7018 ABS : 3Y H5 BV : 3Y H5 CE : EN 13479 DNV-GL : 3 YH5 LR : 3Y H15 PRS : 3Y H5 UKCA : EN 13479 VdTÜV : 00050

Approvals are based on factory location. Please contact ESAB for more information.

Welding Current	AC, DC+(-)
Diffusible Hydrogen	< 5.0 ml/100g
Alloy Type	Carbon Manganese
Coating Type	Basic covering
Min AC OCV	65 V

Typical Tensile Properties			
Condition	Yield Strength	Tensile Strength	Elongation
ISO			
As Welded	480 MPa	560 MPa	28 %

Typical Charpy V-Notch Properties		
Condition	Testing Temperature	Impact Value
ISO		
As Welded	-40 °C	100 J

Typical Weld Metal Analysis %		
C	Mn	Si
0.07	1.12	0.35

Deposition Data					
Diameter	Current	Voltage	Efficiency (%)	Fusion time per electrode at 90% I max	Deposition Rate
2.5 x 350 mm	75-110 A	23 V	64 %	59 sec	1.0 kg/h
3.2 x 350 mm	90-155 A	22 V	63 %	62.4 sec	1.37 kg/h
3.2 x 450 mm	90-155 A	25 V	67 %	92 sec	1.5 kg/h
4.0 x 450 mm	125-200 A	26 V	68 %	101 sec	2.0 kg/h
5.0 x 450 mm	190-260 A	26 V	72 %	106 sec	2.8 kg/h

OK 48.10 RMn



Low Mn emission welding electrode for manual metal arc welding of carbon steels, carbon manganese steels and fine-grained carbon manganese steels. OK 48.10 RMn deposits a tough, crack-resistant weld metal. The coating is of the low moisture absorption type. Diffusible Hydrogen tested in various conditions shows values below 3 ml/100g.

Specifications

Classifications	SFA/AWS A5.1 : E7018 H4 R EN ISO 2560-A : E 42 4 B 42 H5
Approvals	CE : EN13479 DNV : 3 YH5 RINA : 3YH5 UKCA : EN13479

Approvals are based on factory location. Please contact ESAB for more information.

Welding Current	DC+(-)
Diffusible Hydrogen	< 4.0 ml/100g
Alloy Type	Carbon Manganese
Coating Type	Basic covering

Typical Tensile Properties

Condition	Yield Strength	Tensile Strength	Elongation
AWS			
As Welded	480 MPa	560 MPa	25 %
ISO			
As Welded	460 MPa	560 MPa	28 %

Typical Charpy V-Notch Properties

Condition	Testing Temperature	Impact Value
AWS		
As Welded	-30 °C	160 J
ISO		
As Welded	-40 °C	140 J

Typical Weld Metal Analysis %

C	Mn	Si	S	P	Ni	Cr	Mo	V
0.07	0.6	0.6	0.01	0.01	0.2	0.15	0.05	0.02

Deposition Data

Diameter	Current	Voltage	Efficiency (%)	Fusion time per electrode at 90% I max	Deposition Rate
2.5 x 350 mm	70-110 A	24 V	67 %	57 sec	0.96 kg/h
3.2 x 450 mm	90-140 A	23 V	73 %	85 sec	1.33 kg/h
4.0 x 450 mm	120-190 A	24 V	71 %	92 sec	1.76 kg/h

OK 48.50



General purpose AC and DC(-) basic electrode for mild and low alloy steels. The running characteristics are very good. It is a Low Moisture Absorption (LMA) type coating.

Specifications	
Classifications	SFA/AWS A5.1 : E7018-1 H4R EN ISO 2560-A : E 42 4 B 32 H5
Approvals	ABS : 3Y H5 BV : 3Y H5 CE : EN 13479 DNV : 3Y H5 LR : 3Y H5 RINA : 3Y H5 UKCA : EN 13479 VdTÜV : 11813

Approvals are based on factory location. Please contact ESAB for more information.

Welding Current	AC, DC+(-)
Diffusible Hydrogen	< 4.0 ml/100g
Alloy Type	Carbon Manganese
Coating Type	Basic covering
Min AC OCV	65 V

Typical Tensile Properties			
Condition	Yield Strength	Tensile Strength	Elongation
ISO			
As Welded	500 MPa	570 MPa	28 %

Typical Charpy V-Notch Properties		
Condition	Testing Temperature	Impact Value
ISO		
As Welded	-40 °C	70 J

Typical Weld Metal Analysis %		
C	Mn	Si
0.07	1.09	0.49

Deposition Data					
Diameter	Current	Voltage	Efficiency (%)	Fusion time per electrode at 90° I max	Deposition Rate
2.0 x 300 mm	55-90 A	22 V	65 %	45 sec	0.63 kg/h
2.5 x 300 mm	70-110 A	23 V	60 %	53 sec	0.8 kg/h
2.5 x 350 mm	70-110 A	22 V	63 %	63 sec	0.8 kg/h
3.2 x 450 mm	100-150 A	23 V	64 %	92 sec	1.2 kg/h
4.0 x 450 mm	130-200 A	22 V	65 %	101 sec	1.6 kg/h
5.0 x 450 mm	160-260 A	22 V	68 %	109 sec	2.3 kg/h

OK 48.60



General purpose basic DC+ electrode for mild and low alloy steels. Very good running characteristics.

Specifications	
Classifications	SFA/AWS A5.1 : E7018 EN ISO 2560-A : E 42 4 B 42 H5
Approvals	ABS : 3Y H5 BV : 3Y H5 CE : EN 13479 DB : 10.039.23 DNV : 3Y H5 LR : 3Y H5 UKCA : EN 13479 VdTÜV : 10094

Approvals are based on factory location. Please contact ESAB for more information.

Welding Current	DC+
Diffusible Hydrogen	< 5.0 ml/100g
Alloy Type	Carbon Manganese
Coating Type	Basic covering

Typical Tensile Properties			
Condition	Yield Strength	Tensile Strength	Elongation
ISO			
As Welded	445 MPa	540 MPa	28 %

Typical Charpy V-Notch Properties		
Condition	Testing Temperature	Impact Value
ISO		
As Welded	-40 °C	70 J

Typical Weld Metal Analysis %		
C	Mn	Si
0.06	1.1	0.5

Deposition Data					
Diameter	Current	Voltage	Efficiency (%)	Fusion time per electrode at 90% I max	Deposition Rate
2.5 x 350 mm	70-110 A	24 V	67 %	57 sec	0.96 kg/h
3.2 x 350 mm	90-140 A	23 V	70 %	68 sec	1.24 kg/h
3.2 x 450 mm	90-140 A	23 V	73 %	85 sec	1.33 kg/h
4.0 x 350 mm	120-190 A	24 V	70 %	75 sec	1.63 kg/h
4.0 x 450 mm	120-190 A	24 V	71 %	92 sec	1.76 kg/h
5.0 x 450 mm	190-260 A	24 V	75 %	99 sec	2.61 kg/h

OK 50.40



OK 50.40 is an all-round electrode for positional welding mild steel, also well suited for pipe welding. It is particularly good for welding in the vertical upward position and for welding root beads.

Specifications	
Classifications	SFA/AWS A5.1 : E6013 EN ISO 2560-A : E 42 2 RB 12
Approvals	CE : EN 13479 DB : 10.039.14 UKCA : EN 13479 VdTÜV : 00629

Approvals are based on factory location. Please contact ESAB for more information.

Welding Current	AC, DC+-
Alloy Type	Carbon Manganese
Coating Type	Rutile-basic covering
Min AC OCV	60V

Typical Tensile Properties			
Condition	Yield Strength	Tensile Strength	Elongation
ISO			
As Welded	470 MPa	540 MPa	25 %

Typical Charpy V-Notch Properties		
Condition	Testing Temperature	Impact Value
ISO		
As Welded	-20 °C	75 J

Typical Weld Metal Analysis %		
C	Mn	Si
0.07	0.9	0.4

Deposition Data					
Diameter	Current	Voltage	Efficiency (%)	Fusion time per electrode at 90% I max	Deposition Rate
2.5 x 350 mm	50-100 A	23 V	80 %	51 sec	0.8 kg/h
3.2 x 350 mm	80-150 A	24 V	55 %	53 sec	1.15 kg/h
4.0 x 450 mm	130-190 A	22 V	150 %	90 sec	1.5 kg/h

OK 53.05



OK 53.05 is a low-hydrogen electrode with especially good running characteristics and very good mechanical properties. Because of its double coating, it produces a deep crater, which stabilises the arc and gives good protection in inclined positions.

Specifications	
Classifications	SFA/AWS A5.1 : E7016 EN ISO 2560-A : E 42 4 B 22 H10
Approvals	ABS : 3Y CE : EN 13479 DB : 10.039.32 DNV : 3Y H10 LR : 3Y H10 UKCA : EN 13479 VdTUV : 03180

Approvals are based on factory location. Please contact ESAB for more information.

Welding Current	DC+-
Alloy Type	Carbon Manganese
Coating Type	Basic covering

Typical Tensile Properties			
Condition	Yield Strength	Tensile Strength	Elongation
ISO			
As Welded	470 MPa	540 MPa	28 %

Typical Charpy V-Notch Properties		
Condition	Testing Temperature	Impact Value
ISO		
As Welded	-40 °C	80 J

Typical Weld Metal Analysis %		
C	Mn	Si
0.06	0.96	0.54

Deposition Data					
Diameter	Current	Voltage	Efficiency (%)	Fusion time per electrode at 90° I max	Deposition Rate
2.5 x 350 mm	50-100 A	24 V	63 %	49 sec	1.0 kg/h
3.2 x 350 mm	80-140 A	26 V	60 %	57 sec	1.2 kg/h
3.2 x 450 mm	80-140 A	26 V	61 %	70 sec	1.3 kg/h
4.0 x 350 mm	110-180 A	25 V	63 %	60 sec	1.8 kg/h
4.0 x 450 mm	110-180 A	24 V	63 %	82 sec	1.7 kg/h

OK 53.16 SPEZIAL



OK 53.16 is a double coated electrode combining the running characteristics of a rutile with the mechanical properties of a basic electrode. The double coating enables it to be used with small transformers with low OCV. OK 53.16 welds on both AC and DC.

Specifications	
Classifications	SFA/AWS A5.1 : E7016 EN ISO 2560-A : E 38 2B 32 H10
Approvals	ABS : 3Y BV : 3Y H10 CE : EN 13479 DB : 10.039.29 DNV : 3 YH10 LR : 3Y UKCA : EN 13479 VdTÜV : 02762

Approvals are based on factory location. Please contact ESAB for more information.

Welding Current	AC, DC+-
Diffusible Hydrogen	< 10.0 ml/100g
Alloy Type	Carbon Manganese
Coating Type	Basic covering
Min AC OCV	50 V

Typical Tensile Properties			
Condition	Yield Strength	Tensile Strength	Elongation
ISO			
As Welded	450 MPa	530 MPa	28 %

Typical Weld Metal Analysis %		
C	Mn	Si
0.07	1.0	0.6

Deposition Data					
Diameter	Current	Voltage	Efficiency (%)	Fusion time per electrode at 90% I max	Deposition Rate
2.5 x 350 mm	50-90 A	27 V	58 %	59 sec	0.73 kg/h
3.2 x 350 mm	90-150 A	31 V	54 %	56 sec	1.2 kg/h
3.2 x 450 mm	90-150 A	30 V	57 %	72 sec	1.27 kg/h
4.0 x 450 mm	120-190 A	28 V	59 %	90 sec	1.65 kg/h
5.0 x 450 mm	160-230 A	28 V	61 %	109 sec	2.14 kg/h

OK 53.68



A high quality LMA electrode, particularly suitable for on site welding. The electrode yields a homogeneous, high quality weld metal with extra low content of impurities. It operates well on AC as well as DC positive and negative. DC negative is preferred, as it produces a small easily controlled weld pool, minimising the risk of burn through or undercutting. The electrode is CTOD tested.

Specifications

Classifications	SFA/AWS A5.1 : E7016-1 H4 R EN ISO 2560-A : E 42 5 B 12 H5
Approvals	ABS : 3Y H5 BV : 3Y H5 CE : EN 13479 DNV-GL : 4 YH5 PRS : 3Y H5 VdTÜV : 06807

Approvals are based on factory location. Please contact ESAB for more information.

Welding Current	AC, DC+(-)
Diffusible Hydrogen	< 4.0 ml/100g
Alloy Type	Carbon Manganese
Coating Type	Basic covering
Min AC OCV	65 V

Typical Tensile Properties

Condition	Yield Strength	Tensile Strength	Elongation
ISO			
As Welded	470 MPa	550 MPa	30 %

Typical Charpy V-Notch Properties

Condition	Testing Temperature	Impact Value
ISO		
As Welded	-45 °C	150 J
As Welded	-50 °C	140 J

Typical Weld Metal Analysis %

C	Mn	Si
0.06	1.2	0.4

Deposition Data

Diameter	Current	Voltage	Efficiency (%)	Fusion time per electrode at 90% I max	Deposition Rate
2.5 x 350 mm	55-85 A	22 V	58 %	50 sec	0.8 kg/h
3.2 x 450 mm	80-130 A	22 V	61 %	73 sec	1.2 kg/h
4.0 x 450 mm	110-170 A	22 V	65 %	83 sec	1.7 kg/h

OK 53.70



A low hydrogen AC/DC electrode for one side welding of pipes and general structures. The root penetration is good, leaving a flat bead with easy removable slag. The stable arc and the well balanced slag system make the electrode easy to weld in all positions. Suitable for welding of transmission pipelines made from pipe steels up to API 5LX56. It is also suitable for welding the root in higher strength pipes, API 5LX60, 5LX65, 5LX70.

Specifications	
Classifications	SFA/AWS A5.1 : E7016-1 EN ISO 2560-A : E42 5 B 12 H5
Approvals	ABS : E7016-H4 ABS : 3Y H5 CE : EN 13479 DNV-GL : 3 YH5 LR : 3Y H5 UKCA : EN 13479

Approvals are based on factory location. Please contact ESAB for more information.

Welding Current	AC, DC+(-)
Diffusible Hydrogen	< 5.0 ml/100g
Alloy Type	Carbon Manganese
Coating Type	Basic covering
Min AC OCV	60V

Typical Tensile Properties			
Condition	Yield Strength	Tensile Strength	Elongation
ISO			
As Welded	440 MPa	530 MPa	30 %

Typical Charpy V-Notch Properties		
Condition	Testing Temperature	Impact Value
ISO		
As Welded	-50 °C	100 J

Typical Weld Metal Analysis %		
C	Mn	Si
0.06	1.1	0.4

Deposition Data					
Diameter	Current	Voltage	Efficiency (%)	Fusion time per electrode at 90° I max	Deposition Rate
2.0 x 300 mm	50-90 A	27 V	61 %	18 sec	1.63 kg/h
2.5 x 350 mm	60-85 A	26 V	63 %	57 sec	0.7 kg/h
3.2 x 350 mm	80-130 A	24 V	59 %	61 sec	1.1 kg/h
4.0 x 450 mm	115-190 A	24 V	63 %	86 sec	1.7 kg/h
5.0 x 450 mm	150-250 A	24 V	66 %	104 sec	2.26 kg/h

OK 55.00



OK 55.00 is a reliable, high-quality, LMA electrode, particularly suitable for welding high strength low-alloy steels. The good, low-temperature impact strength of the weld metal should be noted. The weld metal is also very resistant to hot cracking. The electrode is also suitable for welding high strength ships steel, grades A, D and E. Tested according to NACE TM0177 and TM0284. Diffusible Hydrogen tested in various conditions show values below 3 ml/100g.

Specifications

Classifications	SFA/AWS A5.1 : E7018-1H4 R CSA W48 : E4918-1-H4 EN ISO 2560-A : E 46 5 B 32 H5
Approvals	ABS : 4YQ420 H5 BV : 3Y H5 CE : EN 13479 CWB : E4918-1-H4 DB : 10.039.03 DNV-GL : 3Y H5 LR : 3Y H5 UKCA : EN 13479 VdTUV : 00632

Approvals are based on factory location. Please contact ESAB for more information.

Welding Current	AC, DC+
Diffusible Hydrogen	< 4.0 ml/100g
Alloy Type	Carbon Manganese
Coating Type	Basic covering
Min AC OCV	65 V

Typical Tensile Properties

Condition	Yield Strength	Tensile Strength	Elongation
ISO			
As Welded	500 MPa	590 MPa	28 %

Typical Charpy V-Notch Properties

Condition	Testing Temperature	Impact Value
AWS		
As Welded	-45 °C	105 J
ISO		
As Welded	-50 °C	100 J

Typical Weld Metal Analysis %

C	Mn	Si
0.06	1.5	0.5

Deposition Data

Diameter	Current	Voltage	Efficiency (%)	Fusion time per electrode at 90% I max	Deposition Rate
2.5 x 350 mm	80-110 A	23 V	64 %	64 sec	0.9 kg/h
3.2 x 350 mm	110-140 A	23 V	62 %	72 sec	1.2 kg/h
3.2 x 450 mm	110-140 A	24 V	69 %	88 sec	1.4 kg/h
4.0 x 350 mm	110-200 A	23 V	62 %	72 sec	1.77 kg/h

OK 55.00

Deposition Data

Diameter	Current	Voltage	Efficiency (%)	Fusion time per electrode at 90% I max	Deposition Rate
4.0 x 450 mm	110-200 A	24 V	70 %	94 sec	2.0 kg/h
5.0 x 450 mm	200-270 A	24 V	72 %	94 sec	3.0 kg/h
6.0 x 450 mm	215-360 A	25 V	72 %	98 sec	4.0 kg/h

OK Femax 33.60



High-recovery rutile electrode particularly suitable for horizontal- vertical fillet welding of thin and medium thick plates. Suitable for long run-out lengths.

Specifications

Classifications	SFA/AWS A5.1 : E7024 EN ISO 2560-A : E 42 0 RR 53
Approvals	CE : EN 13479 DB : 10.039.11 DNV-GL : 2 VdTUV : 01030

Approvals are based on factory location. Please contact ESAB for more information.

Welding Current	AC, DC+(-)
Alloy Type	Carbon Manganese
Coating Type	Rutile thick covering
Min AC OCV	50

Typical Tensile Properties

Condition	Yield Strength	Tensile Strength	Elongation
ISO			
As Welded	460 MPa	540 MPa	27 %

Typical Charpy V-Notch Properties

Condition	Testing Temperature	Impact Value
ISO		
As Welded	0 °C	60 J

Typical Weld Metal Analysis %

C	Mn	Si
0.07	0.7	0.4

Deposition Data

Diameter	Current	Voltage	Efficiency (%)	Fusion time per electrode at 90% I max	Deposition Rate
3.2 x 450 mm	130-170 A	30 V	68 %	71 sec	2.2 kg/h
4.0 x 450 mm	150-230 A	33 V	68 %	77 sec	3.1 kg/h
5.0 x 450 mm	200-350 A	35 V	68 %	78 sec	4.9 kg/h
6.0 x 450 mm	280-450 A	36 V	68 %	83 sec	6.4 kg/h

OK Femax 33.80



High-recovery rutile electrode for high productivity welding of fillets in the horizontal-vertical position. Particularly suitable for welding thick plates and for long run-out lengths. Good bead appearance. Easy slag removal.

Specifications	
Classifications	SFA/AWS A5.1 : E7024 EN ISO 2560-A : E 42 0 RR 73
Approvals	ABS : 2Y ABS : E7024 BV : 2Y CE : EN 13479 CWB : E4924 DB : 10.039.28 DNV-GL : 2Y LR : 2Y PRS : 2Y RINA : 2Y UKCA : EN 13479 VdTUV : 00634

Approvals are based on factory location. Please contact ESAB for more information.

Welding Current	AC, DC+-
Alloy Type	Carbon Manganese
Coating Type	Rutile thick covering
Min AC OCV	50

Typical Tensile Properties			
Condition	Yield Strength	Tensile Strength	Elongation
ISO			
As Welded	460 MPa	550 MPa	27 %

Typical Charpy V-Notch Properties		
Condition	Testing Temperature	Impact Value
ISO		
As Welded	0 °C	60 J

Typical Weld Metal Analysis %		
C	Mn	Si
0.09	0.7	0.4

Deposition Data					
Diameter	Current	Voltage	Efficiency (%)	Fusion time per electrode at 90° I max	Deposition Rate
3.2 x 450.0 mm	130-170 A	28 V	68 %	69 sec	2.5 kg/h
4.0 x 450.0 mm	180-230 A	30 V	68 %	69 sec	3.8 kg/h
5.0 x 450.0 mm	250-340 A	30 V	67 %	68 sec	5.8 kg/h
6.0 x 450.0 mm	300-430 A	35 V	68 %	79 sec	7.1 kg/h

OK Femax 38.65



High-recovery zircon-basic electrode, especially developed for making butt welds and fillet welds in the flat position in carbon steels, carbon manganese steels and fine-grained manganese steels with elevated yield strength. Good slag removal.

Specifications

Classifications	SFA/AWS A5.1 : E7028 EN ISO 2560-A : E 42 4 B 73 H5
Approvals	ABS : E7028 ABS : 3Y H5 BV : 3Y H5 CE : EN 13479 DB : 10.039.15 DNV-GL : 3 YH5 LR : 3Y H5 PRS : 3Y H5 VdTÜV : 00635

Approvals are based on factory location. Please contact ESAB for more information.

Welding Current	AC, DC+
Diffusible Hydrogen	< 5.0 ml/100g
Alloy Type	Carbon Manganese
Coating Type	Basic covering
Min AC OCV	65

Typical Tensile Properties

Condition	Yield Strength	Tensile Strength	Elongation
ISO			
As Welded	440 MPa	550 MPa	28 %

Typical Charpy V-Notch Properties

Condition	Testing Temperature	Impact Value
ISO		
As Welded	-20 °C	100 J
As Welded	-40 °C	85 J

Typical Weld Metal Analysis %

C	Mn	Si
0.08	1.1	0.4

Deposition Data

Diameter	Current	Voltage	Efficiency (%)	Fusion time per electrode at 90% I max	Deposition Rate
4.0 x 450 mm	170-240 A	36 V	68 %	70 sec	3.7 kg/h
5.0 x 450 mm	225-355 A	40 V	69 %	72 sec	5.7 kg/h

OK Femax 38.95



High-recovery, iron powder electrode, giving approximately 240% recovery. OK 38.95 gives a welding speed comparable to submerged-arc welding: up to 240g of weld metal /minute with 6.0mm electrode. Primarily designed for welding butt and fillet joints in the flat position where it gives a smooth transition to the base material. For welding of carbon steels, carbon manganese steels and fine-grained carbon manganese steels with elevated yield strength.

Specifications

Classifications	SFA/AWS A5.1 : E7028 EN ISO 2560-A : E 38 4 B 73 H10
Approvals	ABS : 3Y H10 BV : 3Y H10 DNV-GL : 3 YH10 LR : 3Y H10

Approvals are based on factory location. Please contact ESAB for more information.

Welding Current	AC, DC+
Diffusible Hydrogen	<8.0 ml/100g
Alloy Type	Carbon - Manganese
Coating Type	Zircon Basic
Min AC OCV	65

Typical Tensile Properties

Condition	Yield Strength	Tensile Strength	Elongation
ISO			
As Welded	400 MPa	500 MPa	30 %

Typical Charpy V-Notch Properties

Condition	Testing Temperature	Impact Value
ISO		
As Welded	-40 °C	90 J

Typical Weld Metal Analysis %

C	Mn	Si
0.06	1.25	0.52

Deposition Data

Diameter	Current	Voltage	Efficiency (%)	Fusion time per electrode at 90% I max	Deposition Rate
4.0 x 450 mm	170-240 A	35 V	67 %	67 sec	3.6 kg/h
5.0 x 450 mm	330-400 A	40 V	70 %	63 sec	9.0 kg/h
6.0 x 450 mm	400-520 A	50 V	71 %	65 sec	13.3 kg/h

OK Femax 39.50



Very fast, high recovery acid electrode for horizontal-vertical fillets, lap and butt joints in mild steels. The electrode gives excellent profile with good, easy removable slag. Tolerates a wide range of run-out lengths.

Specifications

Classifications	SFA/AWS A5.1 : E7027 EN ISO 2560-A : E 42 2 RA 53
Approvals	ABS : 3Y BV : 3Y CE : EN 13479 DB : 10.039.07 DNV-GL : 3 Y LR : 3Y PRS : 3 VdTÜV : 00636

Approvals are based on factory location. Please contact ESAB for more information.

Welding Current	AC, DC+
Alloy Type	Carbon Manganese
Coating Type	Rutile-acid covering
Min AC OCV	65

Typical Tensile Properties

Condition	Yield Strength	Tensile Strength	Elongation
ISO			
As Welded	430 MPa	520 MPa	28 %

Typical Charpy V-Notch Properties

Condition	Testing Temperature	Impact Value
ISO		
As Welded	-20 °C	65 J
As Welded	-30 °C	55 J

Typical Weld Metal Analysis %

C	Mn	Si
0.07	0.7	0.3

Deposition Data

Diameter	Current	Voltage	Efficiency (%)	Fusion time per electrode at 90% I max	Deposition Rate
3.2 x 450 mm	130-170 A	31 V	68 %	69 sec	2.3 kg/h
4.0 x 450 mm	150-230 A	32 V	70 %	71 sec	3.2 kg/h
5.0 x 450 mm	200-350 A	37 V	70 %	65 sec	5.5 kg/h
6.0 x 450 mm	280-400 A	35 V	71 %	86 sec	6.4 kg/h

OK GoldRox



OK GoldRox is a true all-round and all-position rutile electrode. With exceptional arc stability and reduced spatter for decreased cleaning time, start and restart properties that allow for easy tack welds, and brilliant slag removal, novice and experienced welders can rely on OK GoldRox. Available in different package sizes – all fully recyclable – to make sure each pack fits specific job requirements.

Specifications	
Classifications	SFA/AWS A5.1 : E6013 EN ISO 2560-A : E 42 0 RC 11
Approvals	ABS : 2 BV : 2 CE : EN 13479 DB : 10.039.48 DNV : 2 LR : 2 UKCA : EN 13479 VdTÜV : 19622

Approvals are based on factory location. Please contact ESAB for more information.

Welding Current	DC+-, AC
Alloy Type	Carbon Manganese
Coating Type	Rutile-cellulosic covering
Min AC OCV	50 V

Typical Tensile Properties			
Condition	Yield Strength	Tensile Strength	Elongation
ISO			
As Welded	450 MPa	520 MPa	26 %

Typical Charpy V-Notch Properties		
Condition	Testing Temperature	Impact Value
ISO		
As Welded	0 °C	60 J

Typical Weld Metal Analysis %		
C	Mn	Si
0.07	0.45	0.42

Deposition Data					
Diameter	Current	Voltage	Efficiency (%)	Fusion time per electrode at 90° l max	Deposition Rate
2.0 x 300 mm	50-70 A	25 V	60 %	38 sec	0.55 kg/h
2.5 x 350 mm	60-90 A	25 V	62 %	49 sec	0.8 kg/h
3.2 x 350 mm	90-140 A	24 V	59 %	57 sec	1.1 kg/h
4.0 x 350 mm	110-185 A	26 V	58 %	64 sec	1.4 kg/h

PIPEWELD 6010 PLUS



Cellulosic-coated electrode designed for welding of pipes and pipelines in all positions using conventional and stovepipe techniques. Deep penetration in all positions especially vertical down. Suitable for welding pipe steels API 5L up to X56, root pass up to X80. Even though DC+ is advised and easier to control, DC- can be used for root run.

Specifications

Classifications	SFA/AWS A5.1 : E6010 EN ISO 2560-A : E 38 2 C 21
Approvals	F BTS : E 6010

Approvals are based on factory location. Please contact ESAB for more information.

Welding Current	DC+(-)
Alloy Type	Carbon Manganese
Coating Type	Cellulosic covering

Typical Tensile Properties

Condition	Yield Strength	Tensile Strength	Elongation
AWS			
As Welded	480 MPa	590 MPa	22 %

Typical Charpy V-Notch Properties

Condition	Testing Temperature	Impact Value
AWS		
As Welded	-20 °C	50 J
As Welded	-30 °C	40 J

Typical Weld Metal Analysis %

C	Mn	Si
0.11	0.44	0.13

Deposition Data

Diameter	Current	Voltage	Efficiency (%)	Fusion time per electrode at 90% I max	Deposition Rate
2.5 x 350 mm	60-80 A	34 V	79 %	54 sec	0.7 kg/h
3.2 x 350 mm	75-130 A	25 V	69 %	57 sec	1.0 kg/h
4.0 x 350 mm	100-190 A	30 V	63 %	58 sec	1.2 kg/h
5.0 x 350 mm	160-240 A	28 V	71 %	65 sec	1.9 kg/h

FILARC PZ6500

A copper coated, manganese-silicon alloyed rod for GTAW of all general engineering and structural steels with a minimum yield strength of max 420 MPa. The rod is usually welded with pure argon (I1) as the shielding gas.

Specifications	
Classifications	EN ISO 636-A : W 42 3 3Si1 EN ISO 636-A : W 3Si1 SFA/AWS A5.18 : ER70S-6
Approvals	CE : EN 13479 UKCA : EN 13479 VdTÜV : 11842

Approvals are based on factory location. Please contact ESAB for more information.

Alloy Type	Carbon-manganese steel
Shielding Gas	I1 (EN ISO 14175)

Typical Tensile Properties			
Condition	Yield Strength	Tensile Strength	Elongation
EN Ar (I1)			
As Welded	470 MPa	560 MPa	26 %

Typical Charpy V-Notch Properties		
Condition	Testing Temperature	Impact Value
EN Ar (I1)		
As Welded	-30 °C	70 J
As Welded	-40 °C	60 J

Typical Weld Metal Analysis %				
C	Mn	Si	S	P
Ar				
0.05	1.4	0.8	0.015	0.015

Typical Wire Composition %		
C	Mn	Si
0.078	1.46	0.85

OK AristoRod 12.50

The non copper coated OK AristoRod 12.50 is a manganese-silicon alloyed solid wire for GMAW of unalloyed steels, such as general structural, pressure vessel, ship building and for fine-grained carbon-manganese steels for the same purpose with a minimum yield strength of max 420 MPa. The electrode can be welded with either a gas mixture or with pure CO₂ as the shielding gas. The AristoRod wires are suitable for operating at high currents with maintained disturbance free wire feeding giving a stable arc with a low amount of spatter. OK AristoRod 12.50 delivered in the unique Esab Octagonal Marathon Pac is excellent in mechanised welding applications.

Specifications	
Classifications	EN ISO 14341-A : G 38 3 C1 3Si1 EN ISO 14341-A : G 42 4 M20 3Si1 EN ISO 14341-A : G 42 4 M21 3Si1 EN ISO 14341-A : G 3Si1 SFA/AWS A5.18 : ER70S-6 CSA W48 : B-G 49A 3 C1 S6 JIS Z 3312 : YGW 12 (C1)
Approvals	ABS : 3Y SA BV : SA3YM CE : EN 13479 CWB : B-G 49A 3 C1 S6 DB : 42.039.29 DNV-GL : III YMS LR : 3YS H15 PRS : 3YS (C1, M21) UKCA : EN 13479 VdTUV : 10052 CWB : B-G 49A 3 C1 S6 JIS : YGW12 (C1) RINA : 3Y S

Approvals are based on factory location. Please contact ESAB for more information.

Alloy Type	Carbon-manganese steel (Mn/Si-alloyed)
Shielding Gas	M20, M21, C1 (EN ISO 14175)

Typical Tensile Properties			
Condition	Yield Strength	Tensile Strength	Elongation
AWS C1			
As Welded	430 MPa	530 MPa	30 %
EN C1			
As Welded	440 MPa	540 MPa	25 %
EN M21			
As Welded	470 MPa	560 MPa	26 %
Stress Relieved 15 hour(s) 620 °C	370 MPa	495 MPa	28 %

Typical Charpy V-Notch Properties		
Condition	Testing Temperature	Impact Value
AWS C1		
As Welded	-30 °C	75 J
EN C1		
As Welded	20 °C	110 J
As Welded	-30 °C	75 J
EN M21		
As Welded	20 °C	130 J

OK AristoRod 12.50

Typical Charpy V-Notch Properties

Condition	Testing Temperature	Impact Value
Stress Relieved 15 hour(s) 620 °C	20 °C	120 J
As Welded	-20 °C	120 J
Stress Relieved 15 hour(s) 620 °C	-20 °C	90 J
As Welded	-30 °C	100 J
As Welded	-40 °C	90 J
As Welded	-50 °C	70 J

Typical Weld Metal Analysis %

C	Mn	Si	S	P	Cu	Ti+Zr
C1						
0.08	0.94	0.63	0.012	0.013	0.07	<0.01
M21						
0.10	1.11	0.72	0.012	0.013	0.07	<0.01

Typical Wire Composition %

C	Mn	Si
0.08	1.46	0.85

Deposition Data

Diameter	Current	Voltage	Wire Feed Speed	Deposition Rate
0.8 mm	60-200 A	18-24 V	3.2-10.0 m/min	0.8-2.3 kg/h
0.9 mm	70-250 A	18-26 V	3.0-12.0 m/min	0.9-3.5 kg/h
1.0 mm	80-300 A	18-32 V	2.7-15.0 m/min	1.0-5.5 kg/h
1.14 mm	100-350 A	18-34 V	2.6-15.0 m/min	1.2-7.0 kg/h
1.2 mm	120-380 A	18-35 V	2.5-15.0 m/min	1.3-8.0 kg/h
1.32 mm	130-400 A	19-35 V	2.4-15.0 m/min	1.5-8.5 kg/h
1.4 mm	150-420 A	22-36 V	2.3-12.0 m/min	1.6-8.7 kg/h
1.6 mm	225-550 A	28-38 V	2.3-10.0 m/min	2.1-9.4 kg/h
2.0 mm	300-650 A	32-44 V	3.0-7.0 m/min	4.4-10.2 kg/h

OK AristoRod 12.57

The non copper coated OK AristoRod 12.57 is a manganese-silicon bearing solid wire for welding of unalloyed steels, such as general structural, pressure vessel and ship building steels with a minimum tensile strength of 500 MPa, and for fine-grained carbon-manganese steels for the same purpose with a minimum yield strength of max 400 MPa. The electrode can be welded with Ar/20CO₂ or with pure CO₂ as the shielding gas. The wire electrode is suitable for welding at high currents.

Specifications

Classifications	EN ISO 14341-A : G 35 2 C1 2Si EN ISO 14341-A : G 38 3 M21 2Si EN ISO 14341-A : G 2Si SFA/AWS A5.18 : ER70S-3 CAN/CSA-ISO 14341 : B-G 49A 2 C1 S3
Approvals	CE : EN 13479 CWB : B-G 49A 2 C1 S3 DB : 42.039.10 UKCA : EN 13479 VdTUV : 10615

Approvals are based on factory location. Please contact ESAB for more information.

Alloy Type	Carbon-manganese steel (Mn/Si-alloyed)
Shielding Gas	M20, M21, C1 (EN ISO 14175)

Typical Tensile Properties

Condition	Yield Strength	Tensile Strength	Elongation
EN 80Ar/20CO₂ (M21)			
As Welded	420 MPa	515 MPa	26 %
EN CO₂ (C1)			
As Welded	375 MPa	485 MPa	25 %

Typical Charpy V-Notch Properties

Condition	Testing Temperature	Impact Value
EN 80Ar/20CO₂ (M21)		
As Welded	20 °C	140 J
As Welded	-20 °C	110 J
As Welded	-30 °C	90 J
EN CO₂ (C1)		
As Welded	20 °C	125 J
As Welded	-20 °C	90 J

Typical Weld Metal Analysis %

C	Mn	Si	S	P	Cu
CO₂ (C1)					
0.10	0.67	0.41	0.011	0.015	0.07
80Ar/20CO₂ (M21)					
0.10	0.80	0.46	0.011	0.015	0.07

Typical Wire Composition %

C	Mn	Si
0.074	1.05	0.55

OK AristoRod 12.57

Deposition Data				
Diameter	Current	Voltage	Wire Feed Speed	Deposition Rate
0.9 mm	70-250 A	18-26 V	3.0-12.0 m/min	0.9-3.5 kg/h
1.0 mm	80-300 A	18-32 V	2.7-15.0 m/min	1.0-5.6 kg/h
1.2 mm	120-380 A	18-34 V	2.5-15.0 m/min	1.3-8.0 kg/h
1.6 mm	120-380 A	18-34 V	2.5-15.0 m/min	1.3-8.0 kg/h

OK AristoRod 12.62

The Triple desoxidized non copper coated OK AristoRod 12.62 is a wire electrode designed for GMAW of mild and fine grained structural- and pressure vessel steels as well as ship building steels and Onshore-Offshore applications. The wire electrode is capable of producing high quality welds in semi-killed and rimmed steel as well as steel of various carbon levels. Because of added desoxidants, Al-Ti-Zr, the wire electrode can also be used for welding steels with a rusty or dirty surface, without any sacrifice of weld quality. The less fluid weld puddle of OK AristoRod 12.62 makes it easy to control when used out of position. OK AristoRod 12.62 is the preferred wire for all position welding of small diameter pipe.

Specifications

Classifications	EN ISO 14341-A : G 42 3 C1 2Ti EN ISO 14341-A : G 46 4 M21 2Ti EN ISO 14341-A : G 2Ti SFA/AWS A5.18 : ER70S-2
------------------------	--

Alloy Type	Carbon-manganese steel (Mn/Si-alloyed)
Shielding Gas	M21, C1 (EN ISO 14175)

Typical Tensile Properties

Condition	Yield Strength	Tensile Strength	Elongation
EN 80Ar/20CO₂ (M21)			
As Welded	570 MPa	625 MPa	26 %

Typical Charpy V-Notch Properties

Condition	Testing Temperature	Impact Value
EN 80Ar/20CO₂ (M21)		
As Welded	-40 °C	180 J

Typical Weld Metal Analysis %

C	Mn	Si	S	P
CO₂ (C1)				
0.05	0.72	0.46	0.010	0.010
80Ar/20CO₂ (M21)				
0.07	0.85	0.51	0.010	0.010

Typical Wire Composition %

C	Mn	Si
0.06	1.1	0.60

Deposition Data

Diameter	Current	Voltage	Wire Feed Speed	Deposition Rate
0.8 mm	60-200 A	18-24 V	3.2-10.0 m/min	0.8-2.5 kg/h
0.9 mm	70-250 A	18-26 V	3.0-12.0 m/min	0.8-3.3 kg/h
1.0 mm	80-300 A	18-32 V	2.7-15.0 m/min	1.0-5.5 kg/h
1.2 mm	120-380 A	18-35 V	2.5-15.0 m/min	1.3-8.0 kg/h
1.6 mm	225-550 A	28-38 V	2.3-10.0 m/min	2.1-9.4 kg/h

OK AristoRod 12.63

A non copper coated G4Si1/ER70S-6 solid wire with a carefully controlled wire chemistry and a unique surface technology that serves for high feeding and welding performance providing a superior weld metal quality at high currents. Compared with OK AristoRod 12.50, OK AristoRod 12.63 has a slightly higher silicon and manganese content, which increases the weld metal strength. The high silicon content promotes low sensitivity to surface impurities and contributes to smooth, sound welds. The wire is designed for welding of all general structural and engineering unalloyed and low-alloyed carbon-manganese steels. OK AristoRod 12.63 delivered in the unique Esab Octagonal Marathon Pac is an excellent choice in mechanised welding applications

Specifications	
Classifications	EN ISO 14341-A : G 42 3 C1 4Si1 EN ISO 14341-A : G 46 5 M20 4Si1 EN ISO 14341-A : G 46 5 M21 4Si1 EN ISO 14341-B : G 55A 5 M21 S6 EN ISO 14341-A : G 4Si1 SFA/AWS A5.18 : ER70S-6 CSA W48 : B-G 49A 3 C1 S6 EN ISO 14341-B : G S6
Approvals	ABS : 3Y SA BV : SA3YM (C1, M21) CE : EN 13479 CWB : B-G 49A 3 C1 S6 DB : 42.039.30 DNV-GL : III YMS (C1, M21) LR : 3YS H15 (C1, M21) UKCA : EN 13479 VdTÜV : 10051

Approvals are based on factory location. Please contact ESAB for more information.

Alloy Type	Carbon-Manganese steel (Mn/Si-alloyed)
Shielding Gas	M20, M21, C1 (EN ISO 14175)

Typical Tensile Properties			
Condition	Yield Strength	Tensile Strength	Elongation
AWS C1			
As Welded	450 MPa	550 MPa	30 %
EN C1			
As Welded	460 MPa	570 MPa	28 %
EN M20			
As Welded	528 MPa	617 MPa	22 %
EN M21			
As Welded	490 MPa	590 MPa	29 %
Stress Relieved 15 hour(s) 650 °C	385 MPa	520 MPa	-

Typical Charpy V-Notch Properties		
Condition	Testing Temperature	Impact Value
AWS C1		
As Welded	-30 °C	100 J
EN C1		
As Welded	20 °C	110 J
As Welded	-30 °C	75 J
EN M20		
As Welded	-50 °C	102 J
EN M21		
As Welded	20 °C	130 J

OK AristoRod 12.63

Typical Charpy V-Notch Properties

Condition	Testing Temperature	Impact Value
Stress Relieved 15 hour(s) 650 °C	20 °C	120 J
As Welded	-20 °C	120 J
Stress Relieved 15 hour(s) 650 °C	-20 °C	90 J
As Welded	-30 °C	100 J
As Welded	-40 °C	90 J
As Welded	-50 °C	80 J

Typical Weld Metal Analysis %

C	Mn	Si	S	P	Cu
C1					
0.09	1.08	0.70	0.013	0.013	0.05
M20					
0.07	1.39	0.67	0.009	0.01	0.04
M21					
0.10	1.28	0.80	0.013	0.013	0.05

Typical Wire Composition %

C	Mn	Si
0.074	1.68	0.95

Deposition Data

Diameter	Current	Voltage	Wire Feed Speed	Deposition Rate
0.8 mm	60-185 A	18-24 V	3.2-10.0 m/min	0.8-2.5 kg/h
0.9 mm	70-250 A	18-26 V	3.0-12.0 m/min	0.8-3.3 kg/h
1.0 mm	80-300 A	18-32 V	2.7-15.0 m/min	1.0-5.5 kg/h
1.2 mm	120-380 A	18-35 V	2.3-15.0 m/min	1.2-8.0 kg/h
1.4 mm	150-420 A	22-36 V	2.3-12.0 m/min	1.6-8.7 kg/h
1.6 mm	225-550 A	28-38 V	2.3-12.0 m/min	2.1-11.4 kg/h

OK AristoRod 38 Zn

The non copper coated OK AristoRod 38 Zn is a manganese-silicon alloyed solid wire for GMAW of galvanised steels with an outstanding performance in terms of low porosity, low spatter and low risk of burnthrough. The electrode can be welded with a gas mixture (M20/M21). OK AristoRod 38 Zn delivered in the unique ESAB Octagonal Marathon Pac is excellent for mechanised welding applications.

Specifications	
Classifications	EN ISO 14341-A : G 42 3 M20 Z 3Si1 EN ISO 14341-A : G 42 3 M21 Z 3Si1 EN ISO 14341-A : G Z 3Si1 SFA/AWS A5.18 : ER70S-G
Approvals	CE : EN 13479 UKCA : EN 13479

Approvals are based on factory location. Please contact ESAB for more information.

Alloy Type	Carbon-manganese steel (Mn/Si-alloyed)
Shielding Gas	M20, M21 (EN ISO 14175)

Typical Tensile Properties			
Condition	Yield Strength	Tensile Strength	Elongation
AWS M21			
As Welded	440 MPa	540 MPa	29 %
M21 EN ISO			
As Welded	440 MPa	540 MPa	29 %
EN ISO M20			
As Welded	440 MPa	550 MPa	30 %
AWS M20			
As Welded	450 MPa	550 MPa	30 %

Typical Charpy V-Notch Properties		
Condition	Testing Temperature	Impact Value
AWS M21		
As Welded	-30 °C	120 J
M21 EN ISO		
As Welded	-30 °C	100 J
As Welded	-40 °C	100 J
EN ISO M20		
As Welded	-30 °C	110 J
As Welded	-40 °C	110 J
AWS M20		
As Welded	-30 °C	140 J

Typical Weld Metal Analysis %				
C	Mn	Si	S	P
AWS M21				
0.07	1.1	0.6	0.01	0.01

Typical Wire Composition %		
C	Mn	Si
0.07	1.4	0.8

OK AristoRod 38 Zn

Deposition Data

Diameter	Current	Voltage	Wire Feed Speed	Deposition Rate
0.8 mm	50-150 A	15-21.5 V	3.2-11.7 m/min	0.72-2.66 kg/h
1.0 mm	100-300 A	16.5-34.5 V	4.0-14.6 m/min	1.37-5.15 kg/h
1.2 mm	100-300 A	15.5-28 V	2.5-9.6 m/min	1.2-4.8 kg/h

OK Autrod 12.51

A copper coated, G3Si1/ER70S-6 solid wire for GMAW of all general structural and engineering unalloyed and low-alloyed carbon-manganese steels. The electrode may be welded with either a gas mixture or with pure CO₂ as the shielding gas. OK Autrod 12.51 delivered in the unique Esab Octagonal Marathon Pac is an excellent choice in mechanised welding applications

Specifications	
Classifications	EN ISO 14341-A : G 38 3 C1 3Si1 EN ISO 14341-A : G 42 4 M20 3Si1 EN ISO 14341-A : G 42 4 M21 3Si1 EN ISO 14341-A : G 3Si1 SFA/AWS A5.18 : ER70S-6 CSA W48 : B-G 49A 3 C1 S6 JIS Z 3312 : YGW 12(C1)
Approvals	ABS : 3YSA, 3 BV : SA3YM (C1,M21) CE : EN 13479 DB : 42.039.06 DNV-GL : III YMS LR : 3YS H15 UKCA : EN 13479 VdTÜV : 00899 CWB : B-G 49A 3 C1 S6 JIS : YGW12 PRS : 3YS RINA : 3YS RINA : 3YS

Approvals are based on factory location. Please contact ESAB for more information.

Alloy Type	Carbon-manganese steel (Mn/Si-alloyed)
Shielding Gas	M20, M21, C1 (EN ISO 14175)

Typical Tensile Properties			
Condition	Yield Strength	Tensile Strength	Elongation
EN M21			
As Welded	460 MPa	560 MPa	26 %
Stress Relieved 15 hour(s) 620 °C	370 MPa	495 MPa	28 %
EN C1			
As Welded	440 MPa	540 MPa	25 %
AWS C1			
As Welded	430 MPa	530 MPa	30 %

Typical Charpy V-Notch Properties		
Condition	Testing Temperature	Impact Value
EN M21		
As Welded	20 °C	130 J
Stress Relieved 15 hour(s) 620 °C	20 °C	120 J
As Welded	-20 °C	120 J
Stress Relieved 15 hour(s) 620 °C	-20 °C	90 J
As Welded	-30 °C	100 J
As Welded	-40 °C	90 J
EN C1		

OK Autrod 12.51

Typical Charpy V-Notch Properties

Condition	Testing Temperature	Impact Value
As Welded	20 °C	110 J
As Welded	-30 °C	75 J
AWS C1		
As Welded	-30 °C	75 J

Typical Weld Metal Analysis %

C	Mn	Si	S	P
C1				
0.08	0.94	0.63	0.012	0.013
M21				
0.10	1.11	0.72	0.012	0.013

Typical Wire Composition %

C	Mn	Si
0.078	1.46	0.85

Deposition Data

Diameter	Current	Voltage	Wire Feed Speed	Deposition Rate
0.6 mm	30-100 A	15-20 V	5.5-13.0 m/min	0.7-1.7 kg/h
0.8 mm	60-200 A	18-24 V	3.2-10.0 m/min	0.8-2.3 kg/h
0.9 mm	70-250 A	18-26 V	3.0-12.0 m/min	0.9-3.5 kg/h
1.0 mm	80-300 A	18-32 V	2.7-15.0 m/min	1.0-5.5 kg/h
1.14 mm	100-350 A	18-34 V	2.6-15.0 m/min	1.2-7.0 kg/h
1.2 mm	120-380 A	18-35 V	2.5-15.0 m/min	1.3-8.0 kg/h
1.32 mm	130-400 A	19-35 V	2.4-15.0 m/min	1.5-8.5 kg/h
1.4 mm	150-420 A	22-36 V	2.3-12.0 m/min	1.6-8.7 kg/h
1.6 mm	225-550 A	28-38 V	2.3-10.0 m/min	2.1-9.4 kg/h

OK Autrod 12.56

A copper coated, G3Si1 solid wire for GMAW of all general structural and engineering unalloyed and low-alloyed carbon-manganese steels. Compared with OK Autrod 12.51, OK Autrod 12.56 has a slightly wider chemical analysis. The electrode may be welded with either a gas mixture or with pure CO₂ as the shielding gas.

Specifications	
Classifications	EN ISO 14341-A : G 38 2 C1 3Si1 EN ISO 14341-A : G 42 3 M21 3Si1 EN ISO 14341-A : G 3Si1
Approvals	CE : EN 13479 DB : 42.039.01 UKCA : EN 13479 VdTÜV : 05682

Approvals are based on factory location. Please contact ESAB for more information.

Alloy Type	Carbon-manganese steel (Mn/Si-alloyed)
Shielding Gas	M20, M21, C1 (EN ISO 14175)

Typical Tensile Properties			
Condition	Yield Strength	Tensile Strength	Elongation
EN 80Ar/20CO₂ (M21)			
As Welded	420 MPa	530 MPa	26 %
EN CO₂ (C1)			
As Welded	440 MPa	520 MPa	25 %

Typical Charpy V-Notch Properties		
Condition	Testing Temperature	Impact Value
EN 80Ar/20CO₂ (M21)		
As Welded	20 °C	130 J
As Welded	-20 °C	90 J
As Welded	-30 °C	70 J
EN CO₂ (C1)		
As Welded	20 °C	110 J
As Welded	-20 °C	70 J

Typical Weld Metal Analysis %				
C	Mn	Si	S	P
CO₂ (C1)				
0.05	0.89	0.63	0.012	0.013
80Ar/20CO₂ (M21)				
0.06	1.06	0.72	0.012	0.013

Typical Wire Composition %		
C	Mn	Si
0.078	1.46	0.85

Deposition Data				
Diameter	Current	Voltage	Wire Feed Speed	Deposition Rate
0.8 mm	60-200 A	18-24 V	3.2-13.0 m/min	0.8-3.0 kg/h
1.0 mm	80-250 A	18-30 V	2.7-15.0 m/min	1.0-5.6 kg/h
1.2 mm	120-300 A	18-34 V	2.3-15.0 m/min	1.3-8.0 kg/h
1.6 mm	225-550 A	28-38 V	2.3-12.0 m/min	2.1-11.4 kg/h

OK Autrod 12.58

A copper coated, G2Si/ER70S-3 solid wire for GMAW of all general structural and engineering unalloyed and low-alloyed carbon-manganese steels. The electrode may be welded with either a gas mixture or with pure CO₂ as the shielding gas. OK Autrod 12.58 can even be delivered in the unique Esab Octagonal Marathon Pac, which is an excellent choice in mechanised welding applications

Specifications

Classifications	EN ISO 14341-A : G 35 2 C1 2Si EN ISO 14341-A : G 38 3 M21 2Si EN ISO 14341-A : G 2Si SFA/AWS A5.18 : ER70S-3 CSA W48 : B-G 49A 2 C1 S3
Approvals	ABS : 3YSA (C1, M21) BV : SA3YM (C1, M21) CE : EN 13479 DB : 42.039.17 DNV-GL : III YMS (C1, M21) LR : 3YS H15, 3YM H15 (C1, M21) UKCA : EN 13479 VdTÜV : 07653

Approvals are based on factory location. Please contact ESAB for more information.

Alloy Type	Carbon-manganese steel (Mn/Si-alloyed)
Shielding Gas	M20, M21, C1 (EN ISO 14175)

Typical Tensile Properties

Condition	Yield Strength	Tensile Strength	Elongation
EN C1			
As Welded	400 MPa	500 MPa	30 %
EN M21			
As Welded	420 MPa	515 MPa	26 %

Typical Charpy V-Notch Properties

Condition	Testing Temperature	Impact Value
EN C1		
As Welded	20 °C	125 J
As Welded	-20 °C	90 J
EN M21		
As Welded	20 °C	140 J
As Welded	-20 °C	130 J
As Welded	-30 °C	90 J

Typical Weld Metal Analysis %

C	Mn	Si	S	P
C1				
0.08	0.67	0.41	0.011	0.015
M21				
0.10	0.80	0.46	0.011	0.015

Typical Wire Composition %

C	Mn	Si
0.074	1.05	0.55

OK Autrod 12.58

Deposition Data				
Diameter	Current	Voltage	Wire Feed Speed	Deposition Rate
0.6 mm	30-100 A	15-20 V	5.5-13.0 m/min	0.7-1.7 kg/h
0.8 mm	60-200 A	18-24 V	3.2-10.0 m/min	0.8-3.0 kg/h
0.9 mm	70-250 A	18-26 V	3.0-12.0 m/min	0.9-3.6 kg/h
1.0 mm	80-300 A	18-32 V	2.7-15.0 m/min	1.0-5.6 kg/h
1.2 mm	120-380 A	18-34 V	2.5-15.0 m/min	1.3-8.0 kg/h
1.6 mm	225-550 A	28-38 V	2.3-12.0 m/min	2.1-11.4 kg/h

OK Autrod 12.64

A copper coated, G4Si1/ER70S-6 solid wire for GMAW of general structural and engineering unalloyed and low-alloyed carbon-manganese steels. Compared with OK Autrod 12.51, OK Autrod 12.64 has a slightly higher silicon and manganese content, which increases the weld metal strength. The high silicon content promotes low sensitivity to surface impurities and contributes to smooth, sound welds. The electrode may be welded with either a gas mixture or with pure CO₂ as the shielding gas. OK Autrod 12.64 can even be delivered in the unique Esab Octagonal Marathon Pac, which is an excellent choice in mechanised welding applications.

Specifications	
Classifications	EN ISO 636-A : W 46 3 4Si1 EN ISO 14341-A : G 42 3 C1 4Si1 EN ISO 14341-A : G 46 5 M20 4Si1 EN ISO 14341-A : G 46 5 M21 4Si1 EN ISO 636-A : W4Si1 EN ISO 14341-A : G 4Si1 SFA/AWS A5.18 : ER70S-6
Approvals	ABS : 3Y SA BV : SA3YM (C1, M21) CE : EN 13479 CWB : B-G 49A 3 C1 S6 DB : 42.039.11 DNV-GL : III YMS (C1, M21) LR : 3YS H15 (C1, M21) UKCA : EN 13479 VdTUV : 04294

Approvals are based on factory location. Please contact ESAB for more information.

Alloy Type	Carbon-manganese steel (Mn/Si-alloyed)
Shielding Gas	M20, M21, C1 (EN ISO 14175)

Typical Tensile Properties			
Condition	Yield Strength	Tensile Strength	Elongation
AWS C1			
As Welded	450 MPa	550 MPa	30 %
EN M21			
Stress Relieved 15 hour(s) 620 °C	385 MPa	520 MPa	-
EN C1			
As Welded	460 MPa	570 MPa	28 %
EN M20			
As Welded	528 MPa	617 MPa	22 %
EN M21			
As Welded	490 MPa	590 MPa	29 %

Typical Charpy V-Notch Properties		
Condition	Testing Temperature	Impact Value
AWS C1		
As Welded	-30 °C	100 J
EN M21		
Stress Relieved 15 hour(s) 620 °C	20 °C	120 J
Stress Relieved 15 hour(s) 620 °C	-20 °C	90 J
EN C1		
As Welded	20 °C	110 J

OK Autrod 12.64

Typical Charpy V-Notch Properties

Condition	Testing Temperature	Impact Value
As Welded	-30 °C	75 J
EN M20		
As Welded	-50 °C	105 J
EN M21		
As Welded	20 °C	130 J
As Welded	-20 °C	120 J
As Welded	-30 °C	100 J
As Welded	-40 °C	90 J
As Welded	-50 °C	80 J

Typical Weld Metal Analysis %

C	Mn	Si	S	P
C1				
0.09	1.08	0.70	0.013	0.013
M20				
0.07	1.39	0.67	0.009	0.01
M21				
0.10	1.28	0.80	0.013	0.013

Typical Wire Composition %

C	Mn	Si
0.074	1.68	0.95

Deposition Data

Diameter	Current	Voltage	Wire Feed Speed	Deposition Rate
0.8 mm	60-185 A	18-24 V	3.2-10.0 m/min	0.8-2.5 kg/h
0.9 mm	70-250 A	18-26 V	3.0-12.0 m/min	0.8-3.3 kg/h
1.0 mm	80-300 A	18-32 V	2.7-15.0 m/min	1.0-5.5 kg/h
1.2 mm	120-380 A	18-35 V	2.3-15.0 m/min	1.2-8.0 kg/h
1.4 mm	150-420 A	22-36 V	2.5-12.0 m/min	1.7-8.5 kg/h
1.6 mm	225-550 A	28-38 V	2.3-12.0 m/min	2.1-11.4 kg/h
2.0 mm	300-650 A	32-44 V	4.0-15.0 m/min	3.2-12.5 kg/h

OK Autrod 12.64 HP



A copper coated, G4Si1/ER70S-6 solid wire for GMAW of unalloyed and low-alloyed carbon-manganese steels. Compared with typical G4Si1/ER70S-6 wires, OK Autrod 12.64 HP has a slightly higher content of strengthening elements and very low level of impurity elements, which provides higher strength and good impact toughness down to -50°C. The high silicon content promotes low sensitivity to surface impurities and contributes to smooth, sound welds. OK Autrod 12.64 HP has excellent feedability, very consistent welding performance and is particularly suited to be used in general construction, automotive components and mobile machinery industries and in robotic applications. The wire may be welded with either a gas mixture or with pure CO₂ as shielding gas.

Specifications	
Classifications	EN ISO 14341-A : G 46 3 C1 4Si1 EN ISO 14341-A : G 50 5 M20 4Si1 EN ISO 14341-A : G 50 5 M21 4Si1 EN ISO 636-A : W 4Si1 EN ISO 14341-A : G 4Si1 SFA/AWS A5.18 : ER70S-6
Approvals	CE : EN 13479 UKCA : EN 13479 VdTÜV : 20123

Approvals are based on factory location. Please contact ESAB for more information.

Alloy Type	Carbon-manganese steel (Mn/Si-alloyed)
Shielding Gas	M20, M21, C1 (EN ISO 14175)

Typical Tensile Properties			
Condition	Yield Strength	Tensile Strength	Elongation
EN M21			
As Welded	540 MPa	630 MPa	26 %
AWS C1			
As Welded	470 MPa	575 MPa	29 %
EN C1			
As Welded	480 MPa	570 MPa	25 %
EN M20			
As Welded	550 MPa	640 MPa	26 %

Typical Charpy V-Notch Properties		
Condition	Testing Temperature	Impact Value
EN M21		
As Welded	-40 °C	120 J
As Welded	-50 °C	95 J
As Welded	-60 °C	85 J
AWS C1		
As Welded	-20 °C	100 J
As Welded	-29 °C	80 J
EN C1		
As Welded	-30 °C	65 J
EN M20		
As Welded	-40 °C	125 J
As Welded	-50 °C	115 J
As Welded	-60 °C	85 J

OK Autrod 12.64 HP

Typical Weld Metal Analysis %

C	Mn	Si	S	P
M20/M21				
0.08	1.55	0.85	0.008	0.009

Typical Wire Composition %

C	Mn	Si
0.09	1.65	0.97

Deposition Data

Diameter	Current	Voltage	Efficiency (%)	Fusion time per electrode at 90% I max	Deposition Rate
2.5 x 350.0 mm	80-110 A	22 V	62 %	62 sec	0.81 kg/h
3.15 x 350.0 mm	110-140 A	23 V	61 %	70 sec	1.17 kg/h
4.0 x 350.0 mm	140-200 A	23 V	53 %	69 sec	1.84 kg/h
4.0 x 450.0 mm	140-200 A	24 V	68 %	86 sec	1.89 kg/h
5.0 x 450.0 mm	200-270 A	25 V	69 %	93 sec	2.88 kg/h

OK Autrod 12.66

A copper coated solid wire especially designed for downhill circumferential GMAW on pipes in materials such as API 5L (grade 52 up to grade 70). The main applications are pipelines, compressor stations and associated works in the oil and gas distribution industries with special requirements. To meet these requirements the electrode is a "clean" type of EN ISO 14341-A G4Si1 as regards chemical analysis.

Specifications	
Classifications	EN ISO 636-A : W 46 3 4Si1 EN ISO 14341-A : G 42 2 C1 4Si1 EN ISO 14341-A : G 46 3 M21 4Si1 EN ISO 636-A : W 4Si1 EN ISO 14341-A : G 4Si1 SFA/AWS A5.18 : ER70S-6
Approvals	VdTÜV : 10035

Approvals are based on factory location. Please contact ESAB for more information.

Alloy Type	Carbon-manganese steel (Mn/Si-alloyed)
Shielding Gas	M20, M21, C1 (EN ISO 14175)

Typical Tensile Properties			
Condition	Yield Strength	Tensile Strength	Elongation
AWS C1			
As Welded	470 MPa	575 MPa	29 %
EN C1			
As Welded	495 MPa	575 MPa	25 %
EN M21			
As Welded	545 MPa	600 MPa	26 %

Typical Charpy V-Notch Properties		
Condition	Testing Temperature	Impact Value
AWS C1		
As Welded	-20 °C	100 J
As Welded	-29 °C	80 J
EN C1		
As Welded	20 °C	120 J
As Welded	-20 °C	80 J
EN M21		
As Welded	20 °C	140 J
As Welded	-20 °C	100 J
As Welded	-30 °C	80 J

Typical Weld Metal Analysis %				
C	Mn	Si	S	P
C1				
0.06	1.05	0.72	0.009	0.009
M21				
0.07	1.25	0.82	0.009	0.009

Typical Wire Composition %		
C	Mn	Si
0.09	1.65	0.97

OK Autrod 42 LSW

Copper coated OK Autrod 42 LSW is an engineered chemistry filler metal designed to create minimal slag and silica islands on the weld bead. It is recommended for robotic welding applications.

Specifications	
Classifications	EN ISO 14341-A : G 42 3 M20 Z EN ISO 14341-A : G 42 3 M21 Z AWS A5.18 : ER70S-9 EN ISO 14341-B : G 49A 5 M20 SZ EN ISO 14341-A : G Z AWS A5.18 : ER70S-9 EN ISO 14341-B : SZ

Alloy Type	Carbon-manganese steel
Shielding Gas	M20, M21 (EN ISO 14175)

Typical Tensile Properties			
Condition	Yield Strength	Tensile Strength	Elongation
EN ISO M20			
As Welded	470 MPa	555 MPa	23 %
AWS M20			
As Welded	460 MPa	550 MPa	28 %

Typical Charpy V-Notch Properties		
Condition	Testing Temperature	Impact Value
EN ISO M20		
As Welded	-30 °C	160 J
As Welded	-50 °C	130 J
AWS M20		
As Welded	-30 °C	125 J

Typical Wire Composition %				
C	Mn	Si	S	P
0.08	1.6	0.07	0.005	0.01

Pipeweld 70S-6

A copper coated solid wire especially designed for downhill circumferential GMAW on pipes in materials such as API 5L (grade 52 up to grade 70). The main applications are pipelines, compressor stations and associated works in the oil and gas distribution industries with special requirements. To meet these requirements the electrode is a "clean" type of EN ISO 14341-A G4Si1 as regards chemical analysis.

Specifications

Classifications	EN ISO 636-A : W 46 3 4Si1 EN ISO 14341-A : G 42 2 C1 4Si1 EN ISO 14341-A : G 46 3 M21 4Si1 EN ISO 636-A : W 4Si1 EN ISO 14341-A : G4Si1 SFA/AWS A5.18 : ER70S-6
Approvals	VdTÜV : 12430

Approvals are based on factory location. Please contact ESAB for more information.

Alloy Type	Carbon-manganese steel (Mn/Si-alloyed)
-------------------	--

Typical Tensile Properties

Condition	Yield Strength	Tensile Strength	Elongation
AWS C1			
As Welded	470 MPa	575 MPa	29 %
EN C1			
As Welded	485 MPa	575 MPa	25 %
EN M21			
As Welded	535 MPa	600 MPa	26 %

Typical Charpy V-Notch Properties

Condition	Testing Temperature	Impact Value
AWS C1		
As Welded	-20 °C	100 J
As Welded	-29 °C	80 J
EN C1		
As Welded	20 °C	120 J
As Welded	-20 °C	80 J
EN M21		
As Welded	20 °C	140 J
As Welded	-20 °C	100 J
As Welded	-30 °C	80 J

Typical Weld Metal Analysis %

C	Mn	Si	S	P
C1				
0.06	1.05	0.72	0.009	0.009
M21				
0.07	1.25	0.82	0.009	0.009

Typical Wire Composition %

C	Mn	Si
0.09	1.65	0.97

Purus 42

A copper coated, G3Si1/ER70S-6 solid wire for GMAW of carbon-manganese steels. Purus 42 is particularly suited to be used in general construction, automotive components and mobile machinery industries. The wire may be welded with either a gas mixture or with pure CO₂ as the shielding gas. Purus 42 is designed to give a clean weld bead with a minimum of silica islands and low spatter. The wire is suitable for robotic applications at high deposition rates.

Specifications	
Classifications	EN ISO 14341-A : G 38 3 C1 3Si1 EN ISO 14341-A : G 42 4 M20 3Si1 EN ISO 14341-A : G 42 4 M21 3Si1 EN ISO 14341-A : G 3Si1 SFA/AWS A5.18 : ER70S-6
Approvals	CE : EN 13479 CWB : B-G 49A 3 C1 S6 DB : 42.039.43 DNV-GL : III YMS (C1, M21) UKCA : EN 13479 VdTUV : 19190

Approvals are based on factory location. Please contact ESAB for more information.

Alloy Type	Carbon-manganese steel (Mn/Si-alloyed)
Shielding Gas	M20, M21, C1 (EN ISO 14175)

Typical Tensile Properties			
Condition	Yield Strength	Tensile Strength	Elongation
EN M21			
As Welded	470 MPa	560 MPa	25 %
AWS C1			
As Welded	420 MPa	530 MPa	30 %
EN C1			
As Welded	430 MPa	530 MPa	24 %
EN M20			
As Welded	475 MPa	570 MPa	26 %

Typical Charpy V-Notch Properties		
Condition	Testing Temperature	Impact Value
EN M21		
As Welded	20 °C	130 J
As Welded	-30 °C	90 J
As Welded	-40 °C	80 J
AWS C1		
As Welded	-30 °C	80 J
EN C1		
As Welded	20 °C	110 J
As Welded	-30 °C	75 J
As Welded	-40 °C	65 J
EN M20		
As Welded	20 °C	150 J
As Welded	-30 °C	100 J
As Welded	-40 °C	75 J

Typical Wire Composition %		
C	Mn	Si

Purus 42

Typical Wire Composition %

C	Mn	Si
0.08	1.45	0.85

Deposition Data

Diameter	Current	Voltage	Wire Feed Speed	Deposition Rate
0.8 mm	60-200 A	18-24 V	3.2-10.0 m/min	0.8-2.3 kg/h
0.9 mm	70-250 A	18-26 V	3.0-12.0 m/min	0.9-3.5 kg/h
1.0 mm	80-300 A	18-32 V	2.7-15.0 m/min	1.0-5.5 kg/h
1.14 mm	100-350 A	18-34 V	2.6-15.0 m/min	1.2-7.0 kg/h
1.2 mm	120-380 A	18-35 V	2.5-15.0 m/min	1.3-8.0 kg/h
1.32 mm	130-400 A	19-35 V	2.4-15.0 m/min	1.5-8.5 kg/h
1.4 mm	150-420 A	22-36 V	2.3-12.0 m/min	1.6-8.7 kg/h
1.6 mm	225-550 A	28-38 V	2.3-10.0 m/min	2.1-9.4 kg/h

Purus 42 CF

A non copper coated, G3Si1/ER70S-6 solid wire for GMAW of carbon-manganese steels. Purus 42 CF is particularly suited to be used in general construction, automotive components and mobile machinery industries. The wire may be welded with either a gas mixture or with pure CO₂ as the shielding gas. Purus 42 CF is designed to give a clean weld bead with a minimum of silica islands, low fumes and extremely low spatter levels. The wire is suitable for robotic applications at high deposition rates.

Specifications	
Classifications	EN ISO 14341-A : G 38 3 C1 3Si1 EN ISO 14341-A : G 42 4 M20 3Si1 EN ISO 14341-A : G 42 4 M21 3Si1 EN ISO 14341-A : G 3Si1 SFA/AWS A5.18 : ER70S-6
Approvals	CE : EN 13479 CWB : B-G 49A 3 C1 S6 DB : 42.039.44 DNV-GL : III YMS (C1, M21) UKCA : EN 13479 VdTÜV : 19260

Approvals are based on factory location. Please contact ESAB for more information.

Alloy Type	Carbon-manganese steel (Mn/Si-alloyed)
Shielding Gas	M20, M21, C1 (EN ISO 14175)

Typical Tensile Properties			
Condition	Yield Strength	Tensile Strength	Elongation
AWS C1			
As Welded	420 MPa	530 MPa	30 %
EN C1			
As Welded	430 MPa	530 MPa	24 %
EN M21			
As Welded	470 MPa	560 MPa	25 %
EN M20			
As Welded	475 MPa	570 MPa	26 %

Typical Charpy V-Notch Properties		
Condition	Testing Temperature	Impact Value
AWS C1		
As Welded	-30 °C	80 J
EN C1		
As Welded	20 °C	110 J
As Welded	-30 °C	75 J
As Welded	-40 °C	65 J
EN M21		
As Welded	20 °C	130 J
As Welded	-30 °C	90 J
As Welded	-40 °C	80 J
EN M20		
As Welded	20 °C	150 J
As Welded	-30 °C	100 J
As Welded	-40 °C	75 J

Purus 42 CF

Typical Wire Composition %

C	Mn	Si
0.08	1.45	0.85

Deposition Data

Diameter	Current	Voltage	Wire Feed Speed	Deposition Rate
0.8 mm	60-200 A	18-24 V	3.2-10.0 m/min	0.8-2.3 kg/h
0.9 mm	70-250 A	18-26 V	3.0-12.0 m/min	0.9-3.5 kg/h
1.0 mm	80-300 A	18-32 V	2.7-15.0 m/min	1.0-5.5 kg/h
1.14 mm	100-350 A	18-34 V	2.6-15.0 m/min	1.2-7.0 kg/h
1.2 mm	120-380 A	18-35 V	2.5-15.0 m/min	1.3-8.0 kg/h
1.32 mm	130-400 A	19-35 V	2.4-15.0 m/min	1.5-8.5 kg/h
1.4 mm	150-420 A	22-36 V	2.3-12.0 m/min	1.6-8.7 kg/h
1.6 mm	225-550 A	28-38 V	2.3-10.0 m/min	2.1-9.4 kg/h

Purus 46

A copper coated G4Si1/ER70S-6 solid wire for GMAW of carbon-manganese steels. Purus 46 is particularly suited to be used in general construction, automotive components and mobile machinery industries. It has a slightly higher manganese and silicon content than Purus 42 to increase the weld metal strength. The wire may be welded with either a gas mixture or with pure CO₂ as shielding gas. Purus 46 is designed to give a clean weld bead with a minimum of silica islands and spatter. The wire is suitable for robotic applications at high deposition rates.

Specifications	
Classifications	EN ISO 14341-A : G 42 3 C1 4Si1 EN ISO 14341-A : G 46 4 M20 4Si1 EN ISO 14341-A : G 46 4 M21 4Si1 EN ISO 14341-A : G 4Si1 SFA/AWS A5.18 : ER70S-6
Approvals	CE : EN 13479 DB : 42.039.40 DNV-GL : III YMS (C1) DNV-GL : III YMS (M21) UKCA : EN 13479 VdTÜV : 19261

Approvals are based on factory location. Please contact ESAB for more information.

Alloy Type	Carbon-manganese steel (Mn/Si-alloyed)
Shielding Gas	M20, M21, C1 (EN ISO 14175)

Typical Tensile Properties			
Condition	Yield Strength	Tensile Strength	Elongation
EN 80Ar/20CO₂ (M21)			
As Welded	475 MPa	585 MPa	26 %
EN CO₂ (C1)			
As Welded	450 MPa	560 MPa	26 %
EN 92Ar/8CO₂ (M20)			
As Welded	500 MPa	600 MPa	25 %
AWS CO₂ (C1)			
As Welded	450 MPa	560 MPa	29 %

Typical Charpy V-Notch Properties		
Condition	Testing Temperature	Impact Value
EN 80Ar/20CO₂ (M21)		
As Welded	20 °C	130 J
As Welded	-30 °C	70 J
As Welded	-40 °C	60 J
EN CO₂ (C1)		
As Welded	20 °C	120 J
As Welded	-30 °C	70 J
EN 92Ar/8CO₂ (M20)		
As Welded	-30 °C	90 J
As Welded	-40 °C	80 J
AWS CO₂ (C1)		
As Welded	-30 °C	70 J

Typical Wire Composition %		
C	Mn	Si
0.08	1.65	0.90

Purus 46

Deposition Data

Diameter	Current	Voltage	Wire Feed Speed	Deposition Rate
0.8 mm	60-200 A	18-24 V	3.2-10.0 m/min	0.8-2.3 kg/h
0.9 mm	70-250 A	18-26 V	3.0-12.0 m/min	0.9-3.5 kg/h
1.0 mm	80-300 A	18-32 V	2.7-15.0 m/min	1.0-5.5 kg/h
1.14 mm	100-350 A	18-34 V	2.6-15.0 m/min	1.2-7.0 kg/h
1.2 mm	120-380 A	18-35 V	2.5-15.0 m/min	1.3-8.0 kg/h
1.32 mm	130-400 A	19-35 V	2.4-15.0 m/min	1.5-8.5 kg/h
1.4 mm	150-420 A	22-36 V	2.3-12.0 m/min	1.6-8.7 kg/h
1.6 mm	225-550 A	28-38 V	2.3-10.0 m/min	2.1-9.4 kg/h

Purus 46 CF

A non copper coated G4Si1/ER70S-6 solid wire for GMAW of carbon-manganese steels. Purus 46 CF is particularly suited to be used in general construction, automotive components and mobile machinery industries. It has a slightly higher manganese and silicon content than Purus 42 CF to increase the weld metal strength. The wire may be welded with either a gas mixture or with pure CO₂ as shielding gas. Purus 46 CF is designed to give a clean weld bead with a minimum of silica islands, low fumes and extremely low spatter levels. The wire is suitable for robotic applications at high deposition rates.

Specifications	
Classifications	EN ISO 14341-A : G 42 3 C1 4Si1 EN ISO 14341-A : G 46 4 M20 4Si1 EN ISO 14341-A : G 46 4 M21 4Si1 EN ISO 14341-A : G 4Si1 SFA/AWS A5.18 : ER70S-6
Approvals	CE : EN 13479 DB : 42.039.42 DNV-GL : III YMS (C1) DNV-GL : III YMS (M21) UKCA : EN 13479 VdTUV : 19262

Approvals are based on factory location. Please contact ESAB for more information.

Typical Tensile Properties			
Condition	Yield Strength	Tensile Strength	Elongation
EN 80Ar/20CO₂ (M21)			
As Welded	475 MPa	585 MPa	26 %
EN CO₂ (C1)			
As Welded	450 MPa	560 MPa	26 %
EN 92Ar/8CO₂ (M20)			
As Welded	500 MPa	600 MPa	25 %
AWS CO₂ (C1)			
As Welded	450 MPa	560 MPa	29 %

Typical Charpy V-Notch Properties		
Condition	Testing Temperature	Impact Value
EN 80Ar/20CO₂ (M21)		
As Welded	20 °C	130 J
As Welded	-30 °C	70 J
As Welded	-40 °C	60 J
EN CO₂ (C1)		
As Welded	20 °C	120 J
As Welded	-30 °C	70 J
EN 92Ar/8CO₂ (M20)		
As Welded	-30 °C	90 J
As Welded	-40 °C	80 J
AWS CO₂ (C1)		
As Welded	-30 °C	70 J

Typical Wire Composition %		
C	Mn	Si
0.08	1.65	0.90

Purus 46 CF

Deposition Data

Diameter	Current	Voltage	Wire Feed Speed	Deposition Rate
0.8 mm	60-200 A	18-24 V	3.2-10.0 m/min	0.8-2.3 kg/h
0.9 mm	70-250 A	18-26 V	3.0-12.0 m/min	0.9-3.5 kg/h
1.0 mm	80-300 A	18-32 V	2.7-15.0 m/min	1.0-5.5 kg/h
1.14 mm	100-350 A	18-34 V	2.6-15.0 m/min	1.2-7.0 kg/h
1.2 mm	120-380 A	18-35 V	2.5-15.0 m/min	1.3-8.0 kg/h
1.32 mm	130-400 A	19-35 V	2.4-15.0 m/min	1.5-8.5 kg/h
1.6 mm	225-550 A	28-38 V	2.3-10.0 m/min	2.1-9.4 kg/h

Weld G3Si1

A copper coated, G3Si1 solid wire for GMAW of all general structural and engineering unalloyed and low-alloyed carbon-manganese steels. The electrode may be welded with either a gas mixture or with pure CO₂ as the shielding gas.

Specifications	
Classifications	EN ISO 14341-A : G 38 2 C1 3Si1 EN ISO 14341-A : G 42 3 M21 3Si1 EN ISO 14341-A : G 3Si1 SFA/AWS A5.18 : ER70S-6
Approvals	CE : EN 13479 DB : 42.039.39 UKCA : EN 13479 VdTÜV : 13038

Approvals are based on factory location. Please contact ESAB for more information.

Alloy Type	Carbon-manganese steel (Mn/Si-alloyed)
Shielding Gas	M21, C1 (EN ISO 14175)

Typical Tensile Properties			
Condition	Yield Strength	Tensile Strength	Elongation
EN M21			
As Welded	470 MPa	560 MPa	26 %

Typical Charpy V-Notch Properties		
Condition	Testing Temperature	Impact Value
EN M21		
As Welded	-30 °C	70 J

Typical Wire Composition %		
C	Mn	Si
0.078	1.46	0.85

Deposition Data				
Diameter	Current	Voltage	Wire Feed Speed	Deposition Rate
0.8 mm	60-180 A	18-22 V	3.2-11.0 m/min	0.8-2.6 kg/h
1.0 mm	80-250 A	18-30 V	2.7-13.0 m/min	1.0-4.8 kg/h
1.2 mm	120-330 A	18-34 V	2.3-13.0 m/min	1.3-6.9 kg/h

OK Gasrod 98.70

Unalloyed bare welding rods for gas welding of unalloyed steels in applications such as tanks and pipings.

Specifications

Classifications

EN 12536 : O11
SFA/AWS A5.2 : R60

Alloy Type

Non alloyed steel (with 1 % Mn)

Typical Weld Metal Analysis %

C	Mn	Si	S	P
0.1	0.8	0.05	0.02	0.02

Typical Wire Composition %

C	Mn	Si
0.10	1.00	0.22

OK Tigrod 12.60

A copper coated, manganese-silicon alloyed rod for GTAW of all general engineering and structural steels with a minimum yield strength of 380 MPa. The rod is usually welded with pure argon (I1) as the shielding gas.

Specifications	
Classifications	EN ISO 636-A : W 38 4 2Si EN ISO 636-A : W 2Si SFA/AWS A5.18 : ER70S-3
Approvals	ABS : 3Y ABS : ER 70S-3 BV : 3YM CE : EN 13479 DNV-GL : III YM (I1) UKCA : EN 13479 VdTÜV : 11141

Approvals are based on factory location. Please contact ESAB for more information.

Alloy Type	Carbon-manganese steel
Shielding Gas	I1 (EN ISO 14175)

Typical Tensile Properties			
Condition	Yield Strength	Tensile Strength	Elongation
Ar (I1) AWS			
As Welded	450 MPa	540 MPa	33 %
Ar (I1) EN			
As Welded	420 MPa	515 MPa	29 %

Typical Charpy V-Notch Properties		
Condition	Testing Temperature	Impact Value
Ar (I1) AWS		
As Welded	-20 °C	250 J
As Welded	-50 °C	150 J
Ar (I1) EN		
As Welded	-20 °C	260 J
As Welded	-40 °C	160 J
As Welded	-50 °C	150 J

Typical Weld Metal Analysis %				
C	Mn	Si	S	P
Ar				
0.10	1.11	0.72	0.012	0.013

Typical Wire Composition %		
C	Mn	Si
0.10	1.11	0.72

OK Tigrod 12.61

A copper coated, manganese-silicon alloyed rod for GTAW of all general engineering and structural steels with a minimum yield strength of max 420 MPa. The rod is usually welded with pure argon (I1) as the shielding gas.

Specifications

Classifications	EN ISO 636-A : W 42 3 3Si1 EN ISO 636-A : W 3Si1 SFA/AWS A5.18 : ER70S-6
Approvals	CE : EN 13479 DB : 42.039.07 UKCA : EN 13479 VdTÜV : 09124

Approvals are based on factory location. Please contact ESAB for more information.

Alloy Type	Carbon-manganese steel
Shielding Gas	I1 (EN ISO 14175)

Typical Tensile Properties

Condition	Yield Strength	Tensile Strength	Elongation
Ar (I1) EN			
As Welded	470 MPa	560 MPa	26 %

Typical Charpy V-Notch Properties

Condition	Testing Temperature	Impact Value
Ar (I1) EN		
As Welded	-30 °C	70 J
As Welded	-40 °C	60 J

Typical Weld Metal Analysis %

C	Mn	Si	S	P
Ar				
0.05	1.4	0.8	0.015	0.015

Typical Wire Composition %

C	Mn	Si
0.078	1.46	0.85

OK Tigrod 12.62

A tripple desoxidized copper coated rod designed for GTAW of mild and fine grained structural- and pressure vessel steels as well as ship building steels. The rod is capable of producing high quality welds in semi-killed and rimmed steel as well as steel of various carbon levels. Because of added desoxidants, Al-Ti-Zr, the rod can also be used for welding steels with a rusty or dirty surface, without any sacrifice of weld quality.

Specifications	
Classifications	EN ISO 636-A : W 46 4 2Ti EN ISO 636-A : W2Ti SFA/AWS A5.18 : ER70S-2
Approvals	CE : EN 13479 UKCA : EN 13479

Approvals are based on factory location. Please contact ESAB for more information.

Alloy Type	Carbon-manganese steel
Shielding Gas	I1 (EN ISO 14175)

Typical Tensile Properties			
Condition	Yield Strength	Tensile Strength	Elongation
Ar (I1) EN			
As Welded	570 MPa	625 MPa	26 %

Typical Charpy V-Notch Properties		
Condition	Testing Temperature	Impact Value
Ar (I1) EN		
As Welded	-40 °C	180 J

Typical Weld Metal Analysis %				
C	Mn	Si	S	P
Ar				
0.05	1.11	0.72	0.012	0.013

Typical Wire Composition %		
C	Mn	Si
0.06	1.1	0.6

OK Tigrod 12.64

A copper coated, G4Si1/ER70S-6 rod for GTAW of general structural and engineering unalloyed and low-alloyed carbon-manganese steels. Compared with OK Tigrod 12.61, OK Tigrod 12.64 has a slightly higher silicon and manganese content, which increases the weld metal strength. The high silicon content promotes low sensitivity to surface impurities and contributes to smooth, sound welds.

Specifications	
Classifications	EN ISO 636-A : W 46 5 4Si1 EN ISO 636-A : W 4Si1 SFA/AWS A5.18 : ER70S-6
Approvals	ABS : 3Y (I1) BV : 3YM CE : EN 13479 DNV-GL : III YM (I1) LR : 3Y H15 (I1) UKCA : EN 13479 VdTÜV : 05260

Approvals are based on factory location. Please contact ESAB for more information.

Alloy Type	Carbon-manganese steel
Shielding Gas	I1 (EN ISO 14175)

Typical Tensile Properties			
Condition	Yield Strength	Tensile Strength	Elongation
Ar (I1) AWS			
As Welded	510 MPa	610 MPa	30 %
Stress Relieved 2 hour(s) 620 °C	400 MPa	525 MPa	32 %
Ar (I1) EN			
As Welded	525 MPa	595 MPa	26 %

Typical Charpy V-Notch Properties		
Condition	Testing Temperature	Impact Value
Ar (I1) AWS		
As Welded	-46 °C	100 J
Stress Relieved 2 hour(s) 620 °C	-46 °C	80 J
Ar (I1) EN		
As Welded	-40 °C	150 J
As Welded	-50 °C	90 J

Typical Weld Metal Analysis %				
C	Mn	Si	S	P
Ar				
0.08	1.28	0.80	0.013	0.015

Typical Wire Composition %		
C	Mn	Si
0.074	1.68	0.95

FILARC PZ6111

A downhand rutile cored wire for use with C1 or M21 shielding gas.

Specifications	
Classifications	SFA/AWS A5.29 : E70T1-G EN ISO 17632-A : T 42 2 1Ni R C1 3 H10 EN ISO 17632-A : T 46 2 1Ni R M21 3 H10
Approvals	ABS : 3SA, 3YSA H10 BV : S3M, S3YM HH CE : EN 13479 DB : 42.105.06 DNV : III YMS (H10) LR : 3YM H10 LR : 3YS H10 PRS : 3YS H10 UKCA : EN 13479 VdTÜV : 03013

Approvals are based on factory location. Please contact ESAB for more information.

Welding Current	DC+
Alloy Type	Low alloy (<1% Ni)

Typical Tensile Properties			
Condition	Yield Strength	Tensile Strength	Elongation
M21 shielding gas			
As Welded	495 MPa	576 MPa	22 %
C1 shielding gas			
As Welded	465 MPa	530 MPa	22 %

Typical Charpy V-Notch Properties		
Condition	Testing Temperature	Impact Value
M21 shielding gas		
As Welded	-20 °C	114 J
C1 shielding gas		
As Welded	-20 °C	89 J

Typical Weld Metal Analysis %			
C	Mn	Si	Ni
Shielding Gas M21			
0.062	1.07	0.53	0.70

Deposition Data				
Diameter	Current	Voltage	Wire Feed Speed	Deposition Rate
1.2 mm	150-350 A	27-38 V	5.8-20.7 m/min	2.1-7.5 kg/h
1.4 mm	150-350 A	26-36 V	3.4-12.0 m/min	1.8-6.3 kg/h
1.6 mm	150-450 A	24-40 V	2.8-12.4 m/min	1.6-8.1 kg/h

FILARC PZ6111HS

A high fill downhand rutile cored wire for high speed welding using either C1 or M21 shielding gas.

Specifications	
Classifications	SFA/AWS A5.29 : E70T1-GC H8 SFA/AWS A5.29 : E70T1-GM H8 EN ISO 17632-A : T 42 2 1Ni R C1 3 H10 EN ISO 17632-A : T 46 2 1Ni R M21 3 H10
Approvals	ABS : 3SA, 3YSA H10 BV : S3YM HH (C1) BV : S3YM HH (M21) CE : EN 13479 DB : 42.105.18 DNV : III Y40MS (H5) (C1) DNV : III Y40MS (H10) (M21) LR : 3YS H10, 3YM H10 UKCA : EN 13479 VdTUV : 07668

Approvals are based on factory location. Please contact ESAB for more information.

Welding Current	DC+
Alloy Type	Low alloy (<1% Ni)
Shielding Gas	M21, C1 (EN ISO 14175)

Typical Tensile Properties			
Condition	Yield Strength	Tensile Strength	Elongation
M21 shielding gas			
As Welded	490 MPa	560 MPa	26 %
C1 shielding gas			
As Welded	465 MPa	540 MPa	27 %

Typical Charpy V-Notch Properties		
Condition	Testing Temperature	Impact Value
M21 shielding gas		
As Welded	-20 °C	97 J
C1 shielding gas		
As Welded	-20 °C	78 J

Typical Weld Metal Analysis %				
C	Mn	Si	S	Ni
Shielding Gas M21				
0.052	1.04	0.53	0.019	0.70

Deposition Data				
Diameter	Current	Voltage	Wire Feed Speed	Deposition Rate
1.6 mm	250-450 A	26-40 V	6.5-19.1 m/min	4.0-12.1 kg/h

FILARC PZ6113

A multi-purpose all positional rutile cored wire for use with C1 or M21 shielding gas.

Specifications	
Classifications	SFA/AWS A5.20 : E71T-1C H4 SFA/AWS A5.20 : E71T-1M H8 EN ISO 17632-A : T 42 3 P C1 1 H5 EN ISO 17632-A : T 46 4 P M21 1 H5 EN ISO 17632-A : T 46 4 P M24 1 H5
Approvals	ABS : 3YSA H5 (C1) ABS : 4YSA H10 (M21) BV : SA3M, SA3YM H5 (C1) BV : SA4YM H5 (M21) CE : EN 13479 DB : 42.105.07 DNV : III YMS(H5) DNV : IV YMS(H5) LR : 3YM H5 LR : 3YS H5 LR : 4YM H10 LR : 4YS H10 PRS : 3YS H5 (C1) PRS : 4YS H10 (M21) RINA : 2Y S H5 RINA : 4Y S H10 UKCA : EN 13479 VdTÜV : 04902

Approvals are based on factory location. Please contact ESAB for more information.

Typical Tensile Properties			
Condition	Yield Strength	Tensile Strength	Elongation
M21 Shielding gas			
As Welded	535 MPa	601 MPa	25 %
C1 Shielding gas			
As Welded	495 MPa	585 MPa	25 %

Typical Charpy V-Notch Properties		
Condition	Testing Temperature	Impact Value
M21 Shielding gas		
As Welded	-40 °C	70 J
C1 Shielding gas		
As Welded	-30 °C	65 J

Typical Weld Metal Analysis %		
C	Mn	Si
C1 shielding gas		
0.06	1.20	0.40

Deposition Data				
Diameter	Current	Voltage	Wire Feed Speed	Deposition Rate
1.0 mm	100-300 A	22-35 V	4.5-23.0 m/min	1.2-6.2 kg/h
1.2 mm	150-350 A	23-35 V	5.8-20.7 m/min	2.1-7.5 kg/h
1.4 mm	150-350 A	22-34 V	3.3-11.6 m/min	1.8-6.3 kg/h



FILARC PZ6113

Deposition Data

Diameter	Current	Voltage	Wire Feed Speed	Deposition Rate
1.6 mm	150-450 A	22-36 V	2.8-12.4 m/min	1.8-8.1 kg/h

FILARC PZ6113S

A multi-purpose all-positional rutile cored wire for use with C1 shielding gas. Diameters less than 1.4mm are all-positional except vertical down.

Specifications	
Classifications	SFA/AWS A5.20 : E71T-9C H4 EN ISO 17632-A : T 46 3 P C1 2 H5
Approvals	CE : EN 13479 DNV : III YMS(H10) UKCA : EN 13479 VdTUV : 07085

Approvals are based on factory location. Please contact ESAB for more information.

Welding Current	DC+
Alloy Type	CMn
Shielding Gas	C1 (EN ISO 14175)

Typical Tensile Properties			
Condition	Yield Strength	Tensile Strength	Elongation
C1 shielding gas			
As Welded	560 MPa	628 MPa	23.3 %

Typical Charpy V-Notch Properties		
Condition	Testing Temperature	Impact Value
C1 shielding gas		
As Welded	0 °C	140 J
As Welded	-20 °C	125 J
As Welded	-30 °C	109 J

Typical Weld Metal Analysis %		
C	Mn	Si
C1 shielding gas		
0.065	1.27	0.43

Deposition Data				
Diameter	Current	Voltage	Wire Feed Speed	Deposition Rate
1.2 mm	150-350 A	27-38 V	5.8-20.7 m/min	2.1-7.5 kg/h

Coreweld 46 LS

A metal cored wire which gives a very low amount of silica on the weld surface. Designed for welding thin plate (>1mm) as well as thicker sections with argon / carbon dioxide shielding gas. The wider welding arc produced means larger gaps can be bridged than with solid wire.

Specifications	
Classifications	SFA/AWS A5.18 : E70C-6M H4 EN ISO 17632-A : T 46 4 M M20 2 H5 EN ISO 17632-A : T 46 4 M M21 2 H5
Approvals	ABS : 4Y400M H5 BV : 4Y40 H5 (M20 & M21) BV : 4Y40 H5 CE : EN 13479 DB : 42.039.38 DNV : IV Y40MS(H5) (M20 & M21) DNV : IV Y40MS(H5) UKCA : EN 13479 VdTÜV : 12152

Approvals are based on factory location. Please contact ESAB for more information.

Welding Current	DC+
Diffusible Hydrogen	< 4 ml/100g
Alloy Type	C Mn steel
Shielding Gas	M20, M21 (EN ISO 14175)

Typical Tensile Properties			
Condition	Yield Strength	Tensile Strength	Elongation
As Welded	485 MPa	545 MPa	29 %

Typical Charpy V-Notch Properties		
Condition	Testing Temperature	Impact Value
As Welded	-40 °C	72 J

Typical Weld Metal Analysis %			
C	Mn	Si	Ni
0.04	1.25	0.63	0.35

Deposition Data				
Diameter	Current	Voltage	Wire Feed Speed	Deposition Rate
1.2 mm	100-360 A	16-32 V	1.8-13.0 m/min	1.3-8.0 kg/h
1.4 mm	150-380 A	18-34 V	2.5-9.0 m/min	1.8-7.0 kg/h
1.6 mm	150-450 A	17-36 V	2.0-9.3 m/min	1.7-7.8 kg/h

Coreweld 46 RMn

A metal cored wire designed to give both low Mn as well as total welding fume levels. This wire, along with other measures, will assist in meeting new, stricter Health and Safety regulations. The excellent mechanical properties and welding performance associated with ESAB metal cored wires are not comprised at all. Designed for use with Ar/CO₂ shielding gas mixtures.

Specifications

Classifications	SFA/AWS A5.18 : E70C-6M H4 EN ISO 17632-A : T 46 4 M M21 2 H5
Approvals	CE : EN 13479 UKCA : EN 13479

Approvals are based on factory location. Please contact ESAB for more information.

Welding Current	DC+
Diffusible Hydrogen	< 4 ml/100g
Alloy Type	C Mn steel
Shielding Gas	M21 (EN ISO 14175)

Typical Tensile Properties

Condition	Yield Strength	Tensile Strength	Elongation
As Welded	475 MPa	535 MPa	28 %

Typical Charpy V-Notch Properties

Condition	Testing Temperature	Impact Value
As Welded	-20 °C	120 J
As Welded	-40 °C	110 J

Deposition Data

Diameter	Current	Voltage	Wire Feed Speed	Deposition Rate
1.2 mm	100-360 A	16-32 V	1.8-13.0 m/min	1.3-8.0 kg/h

Dual Shield Prime 71 LT H4

A seamless, copper free, cored wire designed to weld thick steel components. The diffusible hydrogen level is consistently below 4ml/100g of deposited weld metal and with the seam of the wire being laser welded this ensures no moisture pick up. The wire is not copper coated which means there is no chance of copper flakes contaminating feed liners, torches and contact tips. Dual Shield Prime 71 LT H4 is designed to weld medium strength steels (>420 MPa, >61 ksi yield strength) and provides excellent impact toughness down to -40 degrees C. Dual Shield Prime 71 LT H4 is designed to be used with either CO₂ (C1) or Ar/CO₂ (M21) shielding gas mixtures.

Specifications

Classifications	EN ISO 17632-B : T494T12 1C1A H5 EN ISO 17632-B : T494T12 1M21A H5 SFA/AWS A5.20 : E71T-1C/1M/9C-J/9M-J-H4 SFA/AWS A5.20 : E71T-12C-J/12M-J-H4 JIS Z 3313 : T49 4 T1-1 C/M A-H5 KS D 7104 : YFL-A503R/YFL-C503R EN ISO 17632-A : T42 4 P C1 1 H5 EN ISO 17632-A : T42 4 P M21 1 H5
Approvals	ABS : 4Y400SA H5 CE : EN 13479 CWB : E491T1-C1A4-CS2-H4 (E491T-12J-H4) CWB : E491T1-M21A4-CS2-H4 (E491T-12MJ-H4) DNV : IV Y40MS H5 (C1) DNV : IV Y40MS H5 (M21) LR : 4Y40S H5 UKCA : EN 13479

Approvals are based on factory location. Please contact ESAB for more information.

Welding Current	DC+
Diffusible Hydrogen	< 4 ml/100g
Alloy Type	C Mn
Shielding Gas	M21, C1 (EN ISO 14175)

Typical Tensile Properties

Condition	Yield Strength	Tensile Strength	Elongation
C1 Shielding gas According to AWS			
As Welded	450 MPa	525 MPa	32 %
M21 Shielding gas According to AWS			
As Welded	480 MPa	540 MPa	32 %

Typical Charpy V-Notch Properties

Condition	Testing Temperature	Impact Value
C1 Shielding gas According to AWS		
As Welded	-30 °C	97 J
As Welded	-40 °C	54 J
M21 Shielding gas According to AWS		
As Welded	-30 °C	117 J
As Welded	-40 °C	78 J

Typical Weld Metal Analysis %

C	Mn	Si	Ni
0.04	1.30	0.40	0.45

Dual Shield Prime 71 LT H4

Deposition Data				
Diameter	Current	Voltage	Wire Feed Speed	Deposition Rate
1.2 mm	170-310 A	25-35 V	6.0-16.5 m/min	2.5-6.2 kg/h
1.6 mm	180-420 A	24-38 V	3.0-13.0 m/min	1.8-7.5 kg/h

Dual Shield 46M RMn

An all-positional rutile cored wire designed to give reduced Mn (RMn) content in the welding fume when used with Ar/CO₂ shielding gas. This wire, along with other measures, will assist in meeting new Health and Safety regulations imposed on users.

Specifications

Classifications	SFA/AWS A5.20 : E71T-1M H8 EN ISO 17632-A : T 46 3 P M21 2
Approvals	CE : EN 13479 UKCA : EN 13479

Approvals are based on factory location. Please contact ESAB for more information.

Welding Current	DC+
Alloy Type	C Mn
Shielding Gas	M21 (EN ISO 14175)

Typical Tensile Properties

Condition	Yield Strength	Tensile Strength	Elongation
M21			
As Welded	497 MPa	588 MPa	27 %

Typical Charpy V-Notch Properties

Condition	Testing Temperature	Impact Value
M21		
As Welded	-20 °C	110 J
As Welded	-30 °C	75 J

Typical Weld Metal Analysis %

C	Mn	Si
M21		
0.05	0.5	0.54

Deposition Data

Diameter	Current	Voltage	Wire Feed Speed	Deposition Rate
1.2 mm	115-300 A	21-31 V	3.2-14.5 m/min	1.3-5.8 kg/h

OK E71T-1

A multi-purpose all positional rutile cored wire for use with C1 or M21 shielding gas.

Specifications	
Classifications	SFA/AWS A5.20 : E71T-1C H4 SFA/AWS A5.20 : E71T-1M H8 EN ISO 17632-A : T 42 2 P C1 1 H5 EN ISO 17632-A : T 46 2 P M21 1 H10
Approvals	ABS : 3YSA H5 (C1) BV : SA3M, SA3YM H5, A3M, A3YM H5 BV : SA4YM H10, A4YM H10 CE : EN 13479 DNV : III YMS(H5) DNV : III YMS(H10) LR : 3Y H5 (C1) LR : 3YM H5 LR : 3YS H5 LR : 4Y40M H5 PRS : 3YS H5 (C1) RINA : 2Y S H5 RINA : 3Y S H5 UKCA : EN 13479

Approvals are based on factory location. Please contact ESAB for more information.

Welding Current	DC+
Alloy Type	C Mn
Shielding Gas	M21, C1 (EN ISO 14175)

Typical Tensile Properties			
Condition	Yield Strength	Tensile Strength	Elongation
M21 shielding gas			
As Welded	490 MPa	580 MPa	26 %
C1 shielding gas			
As Welded	490 MPa	580 MPa	26 %

Typical Charpy V-Notch Properties		
Condition	Testing Temperature	Impact Value
M21 shielding gas		
As Welded	-20 °C	95 J
C1 shielding gas		
As Welded	-20 °C	95 J

Deposition Data				
Diameter	Current	Voltage	Wire Feed Speed	Deposition Rate
1.0 mm	100-300 A	22-35 V	4.5-23.0 m/min	1.2-6.2 kg/h
1.2 mm	150-350 A	23-35 V	5.8-20.7 m/min	2.1-7.5 kg/h
1.4 mm	150-350 A	22-34 V	3.3-11.6 m/min	1.8-6.3 kg/h

OK Tubrod 14.00S

A metal cored wire for submerged arc welding.

Specifications

Classifications	EN ISO 14174 : SA AB 1 67 AC H5 SFA/AWS A5.17 : F7A2-EC1
Approvals	ABS : 3YM (10.71) BV : 3YM (10.71) CE : EN 13479 (10.71) CE : EN 13479 DB : 52.039.13 - 51.039.05 (10.71) DNV : III YM (10.71) GL : 3YM (10.71) LR : 3YM (10.71) VdTÜV : 09143 (10.71)

Approvals are based on factory location. Please contact ESAB for more information.

Welding Current	DC+, AC
Diffusible Hydrogen	< 10 ml/100g
Alloy Type	C Mn

Typical Tensile Properties

Condition	Yield Strength	Tensile Strength	Elongation
EN with OK Flux 10.71			
As Welded	454 MPa	538 MPa	30 %

Typical Charpy V-Notch Properties

Condition	Testing Temperature	Impact Value
EN with OK Flux 10.71		
As Welded	-20 °C	132 J

Typical Weld Metal Analysis %

C	Mn	Si
with OK Flux 10.71		
0.06	1.52	0.47

Deposition Data

Diameter	Current	Voltage	Wire Feed Speed	Deposition Rate
2.4 mm	250-450 A	28-38 V	2.0-5.0 m/min	4.0-9.0 kg/h
3.0 mm	400-700 A	28-40 V	2.5-5.5 m/min	5.5-12.0 kg/h
4.0 mm	500-850 A	28-40 V	2.0-5.0 m/min	6.5-12.5 kg/h

OK Tubrod 14.10

A metal cored wire suitable for the welding of thin plate (>3mm) using M21 shielding gas.

Specifications	
Classifications	SFA/AWS A5.18 : E70C-6M H4 EN ISO 17632-A : T 46 4 M M21 2 H5
Approvals	CE : EN 13479 DB : 42.039.22 DNV : IV YMS(H5) DNV-GL : IV YMS(H5) LR : 4Y46M LR : 4Y46S UKCA : EN 13479 VdTÜV : 05018

Approvals are based on factory location. Please contact ESAB for more information.

Welding Current	DC+
Alloy Type	C Mn
Shielding Gas	M21 (EN ISO 14175)

Typical Tensile Properties			
Condition	Yield Strength	Tensile Strength	Elongation
M21 shielding gas			
As Welded	485 MPa	570 MPa	28.9 %

Typical Charpy V-Notch Properties		
Condition	Testing Temperature	Impact Value
M21 shielding gas		
As Welded	-40 °C	75 J

Typical Weld Metal Analysis %		
C	Mn	Si
M21 shielding gas		
0.075	1.55	0.65

Deposition Data				
Diameter	Current	Voltage	Wire Feed Speed	Deposition Rate
1.2 mm	130-350 A	16-34 V	4.6-18.5 m/min	2.0-8.0 kg/h

OK Tubrod 14.11

A metal cored wire for robotic or automated welding of single and multi-pass fillet welds using M21 and M12 shielding gas. Used in the downhand and horizontal / vertical positions.

Specifications

Classifications	SFA/AWS A5.18 : E70C-6M H4 EN ISO 17632-A : T 42 4 M M21 3 H5
Approvals	ABS : 4Y400SA H5 BV : S3YMH5 BV : S3YM H5 CE : EN 13479 DB : 42.039.28 DNV : IV Y40(H5) DNV-GL : IV Y40(H5) LR : 4Y40M H5 LR : 4Y40S H5 UKCA : EN 13479 VdTÜV : 10010

Approvals are based on factory location. Please contact ESAB for more information.

Welding Current	DC+
Alloy Type	C Mn
Shielding Gas	M12, M21 (EN ISO 14175)

Typical Tensile Properties

Condition	Yield Strength	Tensile Strength	Elongation
M21			
As Welded	453 MPa	558 MPa	32 %

Typical Charpy V-Notch Properties

Condition	Testing Temperature	Impact Value
M21		
As Welded	-40 °C	55 J

Typical Weld Metal Analysis %

C	Mn	Si
Shielding gas: M21		
0.048	1.45	0.64
Shielding gas: M12		
0.050	1.9	0.9

Deposition Data

Diameter	Current	Voltage	Wire Feed Speed	Deposition Rate
1.2 mm	100-350 A	14-32 V	1.8-18.5 m/min	1.3-8.0 kg/h
1.4 mm	150-350 A	18-33 V	3.5-12.1 m/min	2.1-7.2 kg/h

OK Tubrod 14.12

A general purpose metal cored wire for use with M21 or C1 shielding gas. Diameters less than 1.4mm are all-positional.

Specifications	
Classifications	SFA/AWS A5.18 : E70C-6C SFA/AWS A5.18 : E70C-6M EN ISO 17632-A : T 42 2 M C1 1 H10 EN ISO 17632-A : T 42 2 M M21 1 H10
Approvals	ABS : 3YSAH10 ABS : 3YSAH10 BV : SA3YM H10 CE : EN 13479 DB : 42.039.24 DNV : III YMS LR : 3YS H10 RINA : 3Y S UKCA : EN 13479 VdTUV : 06649

Approvals are based on factory location. Please contact ESAB for more information.

Welding Current	DC+-
Diffusible Hydrogen	< 10 ml/100g
Alloy Type	C Mn
Shielding Gas	M21, C1 (EN ISO 14175)

Typical Tensile Properties			
Condition	Yield Strength	Tensile Strength	Elongation
M21 shielding gas EN			
As Welded	481 MPa	586 MPa	27 %

Typical Charpy V-Notch Properties		
Condition	Testing Temperature	Impact Value
M21 shielding gas EN		
As Welded	-20 °C	96 J
As Welded	-29 °C	82 J

Typical Weld Metal Analysis %		
C	Mn	Si
M21 shielding gas		
0.08	1.43	0.60

Deposition Data				
Diameter	Current	Voltage	Wire Feed Speed	Deposition Rate
1.0 mm	80-250 A	14-30 V	2.5-10.0 m/min	1.2-4.2 kg/h
1.2 mm	100-320 A	16-32 V	1.8-12.0 m/min	1.3-7.5 kg/h
1.6 mm	140-450 A	18-36 V	1.5-8.5 m/min	1.6-8.0 kg/h

OK Tubrod 14.13

A general purpose metal cored wire for use with M21 shielding gas. Diameters less than 1.4mm are all-positional except vertical down.

Specifications	
Classifications	SFA/AWS A5.18 : E70C-6M EN ISO 17632-A : T 42 2 M M21 2 H5
Approvals	ABS : 3YSA H5 BV : SA3YM CE : EN 13479 DB : 42.039.03 DNV-GL : III YMS LR : 3YS H5 UKCA : EN 13479 VdTÜV : 09086

Approvals are based on factory location. Please contact ESAB for more information.

Welding Current	DC+
Diffusible Hydrogen	< 5 ml/100g
Alloy Type	C Mn
Shielding Gas	M21 (EN ISO 14175)

Typical Tensile Properties			
Condition	Yield Strength	Tensile Strength	Elongation
M21 shielding gas EN			
As Welded	503 MPa	611 MPa	26 %

Typical Charpy V-Notch Properties		
Condition	Testing Temperature	Impact Value
M21 shielding gas EN		
As Welded	-20 °C	106 J
As Welded	-29 °C	85 J

Typical Weld Metal Analysis %		
C	Mn	Si
M21 Shielding gas		
0.08	1.51	0.63

Deposition Data				
Diameter	Current	Voltage	Wire Feed Speed	Deposition Rate
1.2 mm	100-320 A	16-32 V	1.8-12.0 m/min	1.3-7.5 kg/h
1.4 mm	120-380 A	16-34 V	2.0-9.0 m/min	1.6-7.5 kg/h
1.6 mm	140-450 A	18-36 V	1.5-8.5 m/min	1.6-8.0 kg/h

OK Tubrod 15.00

A basic cored wire for use with M21 or C1 shielding gas. Diameters less than 1.4mm are all-positional.

Specifications	
Classifications	SFA/AWS A5.20 : E71T-5C H4 SFA/AWS A5.20 : E71T-5M H4 EN ISO 17632-A : T 42 3 B C1 2 H5 EN ISO 17632-A : T 42 3 B M21 2 H5
Approvals	CE : EN 13479 DB : 42.039.12 DB : 81.039.03 DNV-GL : III YMS(H5) LR : 3YS H5 (M21) RINA : 3Y S H5 (M21) UKCA : EN 13479 VdTÜV : 02181

Approvals are based on factory location. Please contact ESAB for more information.

Welding Current	DC-
Diffusible Hydrogen	< 4 ml/100g
Alloy Type	C Mn
Shielding Gas	M21, C1 (EN ISO 14175)

Typical Tensile Properties			
Condition	Yield Strength	Tensile Strength	Elongation
M21 shielding gas EN			
As Welded	456 MPa	569 MPa	28 %

Typical Charpy V-Notch Properties		
Condition	Testing Temperature	Impact Value
M21 shielding gas EN		
As Welded	-20 °C	145 J
As Welded	-30 °C	129 J

Typical Weld Metal Analysis %		
C	Mn	Si
M21 shielding gas		
0.06	1.44	0.70

Deposition Data				
Diameter	Current	Voltage	Wire Feed Speed	Deposition Rate
1.0 mm	100-230 A	14-30 V	4.5-13.0 m/min	1.2-4.0 kg/h
1.2 mm	120-300 A	16-32 V	4.0-15.0 m/min	1.7-6.5 kg/h
1.6 mm	140-400 A	24-34 V	3.0-10.5 m/min	2.0-8.0 kg/h
2.4 mm	250-500 A	28-38 V	1.5-6.0 m/min	3.5-9.5 kg/h

OK Tubrod 15.00S

A basic cored wire for submerged arc welding.

Specifications

Classifications	SFA/AWS A5.17 : F7A4-EC1 (OK Flux 10.71) SFA/AWS A5.17 : F7A5-EC1 (OK Flux 10.62) EN ISO 14171-A : S 42 4 AB T3 (OK Flux 10.71)
Approvals	ABS : 3YM BV : A3YM CE : EN 13479 (10.71) CE : EN 13479 DB : 52.039.14 DNV-GL : III YM LR : 3YM PRS : 3YM UKCA : EN 13479 VdTÜV : 09144

Approvals are based on factory location. Please contact ESAB for more information.

Welding Current	DC+, AC
Diffusible Hydrogen	<5ml/100g
Alloy Type	C Mn

Typical Tensile Properties

Condition	Yield Strength	Tensile Strength	Elongation
OK Flux 10.71			
As Welded	463 MPa	556 MPa	29 %
OK Flux 10.62			
As Welded	465 MPa	540 MPa	26 %

Typical Charpy V-Notch Properties

Condition	Testing Temperature	Impact Value
OK Flux 10.71		
As Welded	-40 °C	114 J
OK Flux 10.62		
As Welded	-40 °C	140 J
As Welded	-60 °C	75 J

Typical Weld Metal Analysis %

C	Mn	Si	S	P
OK Flux 10.62				
0.06	1.40	0.35	0.010	0.015
OK Flux 10.71				
0.07	1.61	0.59	0.010	0.015

Deposition Data

Diameter	Current	Voltage	Wire Feed Speed	Deposition Rate
2.4 mm	250-350 A	28-38 V	1.5-2.5 m/min	3.5-9.5 kg/h
3.0 mm	400-800 A	28-40 V	2.5-6.0 m/min	6.0-14.5 kg/h
4.0 mm	500-900 A	28-40 V	2.0-5.5 m/min	7.0-18.0 kg/h

OK Tubrod 15.14

A multi-purpose all positional rutile cored wire for use with C1 or M21 shielding gas. Diameters less than 1.4mm are all-positional except vertical down.

Specifications	
Classifications	SFA/AWS A5.20 : E71T-1C H8 SFA/AWS A5.20 : E71T-1M H8 EN ISO 17632-A : T 46 2 P C1 1 H5 EN ISO 17632-A : T 46 3 P M21 2 H5
Approvals	ABS : 3YSA H5 (C1, M21) BV : SA3YM (C1, M21) CE : EN 13479 DB : 42.039.05 DNV : III YMS (C1, M21) LR : 3YM H5 LR : 3YS H5 PRS : 3YS H10 (C1, M21) RINA : 2Y S H5 RINA : 3Y S H5 UKCA : EN 13479 VdTÜV : 07651

Approvals are based on factory location. Please contact ESAB for more information.

Welding Current	DC+
Diffusible Hydrogen	< 5 ml/100g
Alloy Type	C Mn
Shielding Gas	M21, C1 (EN ISO 14175)

Typical Tensile Properties			
Condition	Yield Strength	Tensile Strength	Elongation
AWS C1			
PWHT 3 hour(s) 620 °C	523 MPa	601 MPa	25.4 %
C1			
As Welded	497 MPa	588 MPa	27 %
M21			
As Welded	590 MPa	661 MPa	23 %

Typical Charpy V-Notch Properties		
Condition	Testing Temperature	Impact Value
AWS C1		
PWHT 3 hour(s) 620 °C	-20 °C	166 J
C1		
As Welded	-20 °C	110 J
M21		
As Welded	-20 °C	120 J
As Welded	-30 °C	90 J

Typical Weld Metal Analysis %		
C	Mn	Si
M21 shielding gas		
0.06	1.40	0.40

Coreshield 8

An all positional self-shielded cored wire ideal for welding outdoor structural steelwork.

Specifications

Classifications	SFA/AWS A5.20 : E71T-8 EN ISO 17632-A : T 42 2 Y N 2
Approvals	ABS : 2YSA H10 BV : S2YM HH CE : EN 13479 CWB : E491T8-A3-CS3-H8 DB : 42.039.35 DNV-GL : II YMS(H10) LR : 2YS H10 UKCA : EN 13479 VdTÜV : 10019

Approvals are based on factory location. Please contact ESAB for more information.

Welding Current	DC-
Alloy Type	C Mn
Shielding Gas	None

Typical Tensile Properties

Condition	Yield Strength	Tensile Strength	Elongation
No shielding gas			
As Welded	457 MPa	552 MPa	26 %

Typical Charpy V-Notch Properties

Condition	Testing Temperature	Impact Value
No shielding gas		
As Welded	-20 °C	75 J
As Welded	-29 °C	63 J

Typical Weld Metal Analysis %

C	Mn	Si	Al
No shielding gas			
0.17	0.45	0.12	0.50

Deposition Data

Diameter	Current	Voltage	Wire Feed Speed	TTW Dist.	Deposition Rate
1.6 mm	135-230 A	18-25 V	3.0-5.8 m/min	13.0 mm	1.77-3.72 kg/h
1.8 mm	150-280 A	18-25 V	2.8-7.1 m/min	19.0 mm	1.86-5.0 kg/h
2.0 mm	175-230 A	18-25 V	3.0-5.8 m/min	19.0 mm	2.18-4.76 kg/h

Coreshield 15

Coreshield 15 is an all-position self-shielded flux cored welding wire for single pass applications. Coreshield 15 produces smooth arc action, full slag coverage, easy slag removal, and low spatter. The use of DCEN (electrode negative) current minimizes the risk of burn-through. Coreshield 15 is excellent for use on lap and fillet welds on thin gauge galvanized and mild steels in all welding positions. The availability of .030" (0.8 mm) diameter makes it possible to use this product on materials as thin as 18 gauge (1.2 mm). The wire is particularly suitable for thin gauge materials 0.030 - 3/16" (0.8-5.0 in.) in galvanized, zinc-aluminum carbon, or aluminised carbon steels. In structural fabrications, the product can be used where no seismic requirements are present.

Specifications	
Classifications	SFA/AWS A5.20 : E71T-14/GS JIS Z 3313 : YFW-S50GB KS D 7104 : YFW-S50GB

Welding Current	DC-
Alloy Type	C Mn
Shielding Gas	None

Typical Tensile Properties	
Condition	Tensile Strength
As Welded	614 MPa

Typical Weld Metal Analysis %			
C	Mn	Si	Al
0.23	0.70	0.40	1.98

Deposition Data					
Diameter	Current	Voltage	Wire Feed Speed	TTW Dist.	Deposition Rate
0.8 mm	75-120 A	14-17 V	2.0-10.0 m/min	-	0.4-1.8 kg/h
0.9 mm	80-120 A	15-17 V	2.06-9.95 m/min	9.5 mm	0.4-2.0 kg/h
1.2 mm	95-150 A	15-18 V	1.37-3.56 m/min	12.5 mm	0.4-1.2 kg/h
1.6 mm	160-275 A	17-19 V	1.42-3.35 m/min	16.0 mm	1.0-2.4 kg/h



OK Autrod 12.10

Copper-coated, unalloyed wire for Submerged Arc Welding. For low requirements or in combination with high Si and Mn alloying fluxes. Suitable for non- and low alloyed steels.

Specifications

Classifications	SFA/AWS A5.17 : EL12 EN ISO 14171-A : S1
Approvals	CE : EN 13479 DB : 52.039.01 UKCA : EN 13479 VdTÜV : 12103

Approvals are based on factory location. Please contact ESAB for more information.

Typical Wire Composition %

C	Mn	Si
0.07	0.52	0.08

OK Autrod 12.20

Copper-coated, unalloyed wire for Submerged Arc and Electroslag Welding. Suitable in combination with most fluxes. For structural steels, ship building steels, pressure vessel steels, fine grained steels, etc.

Specifications	
Classifications	SFA/AWS A5.17 : EM12 EN ISO 14171-A : S2
Approvals	CE : EN 13479 DB : 52.039.02 UKCA : EN 13479 VdTÜV : 12103

Approvals are based on factory location. Please contact ESAB for more information.

Typical Wire Composition %		
C	Mn	Si
0.10	1.06	0.07

OK Autrod 12.22

Copper-coated, unalloyed wire for Submerged Arc Welding. Well suitable to be combined with most fluxes. Increased Si content and thus recommended for neutral fluxes (e.g.: OK Flux 10.62) or in order to increase the fluidity of the molten pool. For structural steels, ship building steels, pressure vessel steels, fine grained steels, etc.

Specifications	
Classifications	SFA/AWS A5.17 : EM12K EN ISO 14171-A : S2Si
Approvals	CE : EN 13479 DB : 52.039.05 UKCA : EN 13479 VdTÜV : 12103

Approvals are based on factory location. Please contact ESAB for more information.

Typical Wire Composition %		
C	Mn	Si
0.09	1.01	0.19

OK Autrod 12.32

Copper-coated, unalloyed wire for Submerged Arc and Electroslag Welding. Increased Si content and thus especially suitable for neutral fluxes (e.g.: OK Flux 10.62) or in order to increase the fluidity of the molten pool. With OK Flux 10.62 excellent toughness values; CTOD tested. For structural steels, ship building steels, pressure vessel steels, fine grained steels, off-shore constructions, etc.

Specifications	
Classifications	SFA/AWS A5.17 : EH12K EN ISO 14171-A : S3Si
Approvals	CE : EN 13479 DB : 52.039.12 UKCA : EN 13479 VdTÜV : 12103 CWB : F49A4-EH12K-H8 CWB : F49A4-EH12K-H4 BlockPac

Approvals are based on factory location. Please contact ESAB for more information.

Typical Wire Composition %		
C	Mn	Si
0.13	1.77	0.30

OK Autrod 12.40

Copper-coated, unalloyed wire for Submerged Arc and Electroslag Welding. For structural steels, ship building steels, pressure vessel steels, fine grained steels, etc.

Specifications

Classifications	SFA/AWS A5.17 : EH14 EN ISO 14171-A : S4
Approvals	VdTÜV : 12103

Approvals are based on factory location. Please contact ESAB for more information.

Typical Wire Composition %

C	Mn	Si
0.12	2.04	0.08

OK Tubrod 14.00S

A metal cored wire for submerged arc welding.

Specifications	
Classifications	EN ISO 14174 : SA AB 1 67 AC H5 SFA/AWS A5.17 : F7A2-EC1
Approvals	ABS : 3YM (10.71) BV : 3YM (10.71) CE : EN 13479 (10.71) CE : EN 13479 DB : 52.039.13 - 51.039.05 (10.71) DNV : III YM (10.71) GL : 3YM (10.71) LR : 3YM (10.71) VdTÜV : 09143 (10.71)

Approvals are based on factory location. Please contact ESAB for more information.

Welding Current	DC+, AC
Diffusible Hydrogen	< 10 ml/100g
Alloy Type	C Mn

Typical Tensile Properties			
Condition	Yield Strength	Tensile Strength	Elongation
EN with OK Flux 10.71			
As Welded	454 MPa	538 MPa	30 %

Typical Charpy V-Notch Properties		
Condition	Testing Temperature	Impact Value
EN with OK Flux 10.71		
As Welded	-20 °C	132 J

Typical Weld Metal Analysis %		
C	Mn	Si
with OK Flux 10.71		
0.06	1.52	0.47

Deposition Data				
Diameter	Current	Voltage	Wire Feed Speed	Deposition Rate
2.4 mm	250-450 A	28-38 V	2.0-5.0 m/min	4.0-9.0 kg/h
3.0 mm	400-700 A	28-40 V	2.5-5.5 m/min	5.5-12.0 kg/h
4.0 mm	500-850 A	28-40 V	2.0-5.0 m/min	6.5-12.5 kg/h

OK Tubrod 15.00S

A basic cored wire for submerged arc welding.

Specifications

Classifications	SFA/AWS A5.17 : F7A4-EC1 (OK Flux 10.71) SFA/AWS A5.17 : F7A5-EC1 (OK Flux 10.62) EN ISO 14171-A : S 42 4 AB T3 (OK Flux 10.71)
Approvals	ABS : 3YM BV : A3YM CE : EN 13479 (10.71) CE : EN 13479 DB : 52.039.14 DNV-GL : III YM LR : 3YM PRS : 3YM UKCA : EN 13479 VdTÜV : 09144

Approvals are based on factory location. Please contact ESAB for more information.

Welding Current	DC+, AC
Diffusible Hydrogen	<5ml/100g
Alloy Type	C Mn

Typical Tensile Properties

Condition	Yield Strength	Tensile Strength	Elongation
OK Flux 10.71			
As Welded	463 MPa	556 MPa	29 %
OK Flux 10.62			
As Welded	465 MPa	540 MPa	26 %

Typical Charpy V-Notch Properties

Condition	Testing Temperature	Impact Value
OK Flux 10.71		
As Welded	-40 °C	114 J
OK Flux 10.62		
As Welded	-40 °C	140 J
As Welded	-60 °C	75 J

Typical Weld Metal Analysis %

C	Mn	Si	S	P
OK Flux 10.62				
0.06	1.40	0.35	0.010	0.015
OK Flux 10.71				
0.07	1.61	0.59	0.010	0.015

Deposition Data

Diameter	Current	Voltage	Wire Feed Speed	Deposition Rate
2.4 mm	250-350 A	28-38 V	1.5-2.5 m/min	3.5-9.5 kg/h
3.0 mm	400-800 A	28-40 V	2.5-6.0 m/min	6.0-14.5 kg/h
4.0 mm	500-900 A	28-40 V	2.0-5.5 m/min	7.0-18.0 kg/h

STICK ELECTRODES (SMAW).....	2-4
Filarc 118	2-4
Filarc 76S	2-5
Filarc 88S	2-6
Filarc 98S	2-8
OK 48.08	2-9
OK 73.08	2-11
OK 73.15	2-12
OK 73.68	2-14
OK 73.79	2-16
OK 74.46	2-17
OK 74.70	2-18
OK 74.78	2-19
OK 74.86 Tensitrode	2-20
OK 75.75	2-21
OK 75.78	2-22
OK 76.18	2-23
OK 76.28	2-24
OK 76.35	2-25
OK 76.96	2-26
OK 76.98	2-27
OK 78.16	2-28
OK B2 SC	2-29
OK B3 SC	2-31
Pipeweld 90DH	2-33
Pipeweld 7010 Plus	2-34
Pipeweld 8010 Plus	2-35
Pipeweld 9010 Plus	2-36
MIG WIRES/TIG RODS (GMAW/GTAW)	2-37
OK AristoRod 13.08	2-37
OK AristoRod 13.09	2-38
OK AristoRod 13.12	2-40
OK AristoRod 13.16	2-42
OK AristoRod 13.22	2-44
OK AristoRod 13.26	2-45
OK AristoRod 55	2-47
OK AristoRod 69	2-49
OK AristoRod 79	2-51
OK AristoRod 89	2-52
OK Autrod 13.17	2-53
OK Autrod 13.23	2-54
OK Autrod 13.25	2-55
OK Autrod 13.28	2-56
OK Autrod 13.29	2-58
OK Autrod 13.37	2-60
OK Tigrod 13.08	2-61
OK Tigrod 13.09	2-62
OK Tigrod 13.12	2-64
OK Tigrod 13.16	2-65
OK Tigrod 13.17	2-66
OK Tigrod 13.22	2-67
OK Tigrod 13.23	2-68
OK Tigrod 13.26	2-69
OK Tigrod 13.28	2-70
OK Tigrod 13.32	2-71
OK Tigrod 13.37	2-72
OK Tigrod 13.38	2-73
OK Tigrod 55	2-75
OK Tigrod B2 SC	2-76
OK Tigrod B3 SC	2-78



GAS-SHIELDED FLUX-CORED WIRES (FCAW/MCAW)	2-80
Coreweld 46 LT H4.....	2-80
Coreweld 55 LT H4.....	2-81
Coreweld 69 LT H4.....	2-82
Coreweld 89.....	2-83
Dual Shield 55.....	2-84
Dual Shield 62.....	2-85
Dual Shield 69.....	2-86
Dual Shield 110C.....	2-87
Dual Shield CrMo1.....	2-88
Dual Shield CrMo2.....	2-89
Dual Shield MoL.....	2-90
Dual Shield Prime 81Ni1 H4.....	2-91
Dual Shield Prime 81Ni1M H4.....	2-92
Filarc PZ6112.....	2-93
Filarc PZ6114.....	2-94
Filarc PZ6115.....	2-95
Filarc PZ6116S.....	2-96
Filarc PZ6125.....	2-97
Filarc PZ6138.....	2-98
Filarc PZ6138SR.....	2-99
Filarc PZ6138S SR.....	2-100
Filarc PZ6222.....	2-101
OK Tubrod 14.01.....	2-102
OK Tubrod 14.02.....	2-103
OK Tubrod 14.03.....	2-104
OK Tubrod 14.04.....	2-105
OK Tubrod 14.05.....	2-106
OK Tubrod 15.09.....	2-107
OK Tubrod 15.11.....	2-108
OK Tubrod 15.17.....	2-109
OK Tubrod 15.19.....	2-110
OK Tubrod 15.20.....	2-111
OK Tubrod 15.22.....	2-112
OK Tubrod 15.24S.....	2-113
OK Tubrod 15.27.....	2-114
OK Tubrod 15.27S.....	2-115
Pipeweld 71T-1.....	2-116
Pipeweld 91T-1.....	2-117
Pipeweld 101T-1.....	2-118
Pipeweld 111T-1.....	2-119



SELF-SHIELDED FLUX-CORED WIRES (FCAW)	2-120
Coreshield 71T-8 OS	2-120
SUBARC (SAW)	2-121
OK Autrod 12.24	2-121
OK Autrod 12.34	2-122
OK Autrod 13.10 SC	2-123
OK Autrod 13.21	2-124
OK Autrod 13.24	2-125
OK Autrod 13.27	2-126
OK Autrod 13.33	2-127
OK Autrod 13.35	2-128
OK Autrod 13.36	2-129
OK Autrod 13.40	2-130
OK Autrod 13.43	2-131
OK Autrod 13.49	2-132
OK Autrod 13.62	2-133
OK Autrod 13.64	2-134
OK Tubrod 15.24S	2-135
OK Tubrod 15.27S	2-136
OK Autrod B2 SC	2-137
OK Autrod B3 SC	2-138

FILARC 118



All position basic AC/DC electrode with 120% recovery for welding high-strength, fine-grained constructional steels (> 690 MPa) with excellent sub-zero toughness down to -50 degrees C and low diffusible hydrogen levels. Use shortest possible arc. Weave slowly when permitted. A slight weave can be used for standing fillet welds. Use DC- for root runs

Specifications

Classifications	SFA/AWS A5.5 : E 11018-M H4R EN ISO 18275-A : E 69 5 Mn2NiMo B 32 H5
Approvals	ABS : E 11018-M CE : EN 13479 DNV-GL : 4 Y62H5 LR : 4Y62 H5 MoD : (N) Q1N HY80

Approvals are based on factory location. Please contact ESAB for more information.

Welding Current	AC, DC+-
Diffusible Hydrogen	< 4.0 ml/100g
Alloy Type	Low alloyed (2.3 % Ni, 0.4 % Mo)
Coating Type	Basic covering
Min AC OCV	65V

Typical Tensile Properties

Condition	Yield Strength	Tensile Strength	Elongation
AWS			
As Welded	730 MPa	800 MPa	22 %
ISO			
As Welded	750 MPa	820 MPa	20 %

Typical Charpy V-Notch Properties

Condition	Testing Temperature	Impact Value
AWS		
As Welded	-50 °C	80 J
ISO		
As Welded	-50 °C	85 J

Typical Weld Metal Analysis %

C	Mn	Si	S	P	Ni	Cr	Mo	V
0.06	1.65	0.32	0.010	0.015	2.27	0.06	0.44	0.015

Deposition Data

Diameter	Current	Voltage	Efficiency (%)	Fusion time per electrode at 90% I max	Deposition Rate
2.5 x 350 mm	65-100 A	25.7 V	63 %	52 sec	0.96 kg/h
3.2 x 350 mm	95-150 A	23.1 V	62 %	67 sec	1.35 kg/h
4.0 x 450 mm	115-190 A	23.3 V	67 %	95 sec	1.79 kg/h
5.0 x 450 mm	190-270 A	24.9 V	68 %	110 sec	2.46 kg/h

FILARC 76S



CTOD tested, all-position basic AC/DC electrode for offshore fabrication. Alloyed with max 1% nickel. Good CVN toughness down to -60° C. CTOD tested in the AW and SR conditions. Use short arc. Weave slowly when permitted. DC+. Use DC- for root pass.

Specifications	
Classifications	SFA/AWS A5.5 : E7018-G H4R EN ISO 2560-A : E 46 6 Mn1Ni B 32 H5
Approvals	ABS : 5YQ420 H5 BV : 5Y42 H5 CE : EN 13479 DNV : 5 Y42 H5 LR : 5Y46 H5 UKCA : EN 13479

Approvals are based on factory location. Please contact ESAB for more information.

Welding Current	AC, DC+-
Diffusible Hydrogen	< 4.0 ml/100g
Alloy Type	Low alloyed (0.9 % Ni)
Coating Type	Basic covering
Min AC OCV	65 V

Typical Tensile Properties			
Condition	Yield Strength	Tensile Strength	Elongation
ISO			
As Welded	560 MPa	630 MPa	25 %

Typical Charpy V-Notch Properties		
Condition	Testing Temperature	Impact Value
ISO		
As Welded	-40 °C	130 J
As Welded	-60 °C	80 J

Typical Weld Metal Analysis %									
C	Mn	Si	S	P	Ni	Cr	Mo	V	Al
0.065	1.65	0.30	0.005	0.015	0.90	0.035	0.01	0.01	0.005

Typical Weld Metal Analysis %		
Cu	Nb	Ti
0.03	0.005	0.01

Deposition Data					
Diameter	Current	Voltage	Efficiency (%)	Fusion time per electrode at 90% I max	Deposition Rate
2.5 x 350 mm	65-100 A	26 V	62 %	52 sec	0.96 kg/h
3.2 x 350 mm	90-150 A	23 V	39 %	67 sec	1.3 kg/h
4.0 x 350 mm	110-190 A	23 V	39 %	74 sec	1.71 kg/h
4.0 x 450 mm	110-190 A	23 V	40 %	95 sec	1.59 kg/h
5.0 x 450 mm	185-235 A	25 V	39 %	110 sec	2.35 kg/h

FILARC 88S



A basic coated low hydrogen electrode alloyed with max 1% Ni for the positional welding of higher tensile steels, S460 steel and similar grades. Good CVN toughness down to -60°C ; CTOD tested in the AW and SR conditions. Many approved welding procedures are available. Use short arc. Weave slowly when permitted. Use DC- for root passes.

Specifications	
Classifications	SFA/AWS A5.5 : E8016-G H4R EN ISO 2560-A : E 50 6 Mn1Ni B 12 H5
Approvals	ABS : E8016-G CE : EN 13479 DB : 10.105.16 DNV : 5 Y46H5 LR : 5Y46 UKCA : EN 13479 VdTÜV : 06107

Approvals are based on factory location. Please contact ESAB for more information.

Welding Current	AC, DC+(-)
Diffusible Hydrogen	< 4.0 ml/100g
Alloy Type	Low alloyed (0.9 % Ni)
Coating Type	Basic covering
Min AC OCV	65

Typical Tensile Properties			
Condition	Yield Strength	Tensile Strength	Elongation
AWS			
As Welded	550 MPa	640 MPa	27 %
PWHT 1 hour(s) 620 °C	520 MPa	590 MPa	28 %
ISO			
As Welded	560 MPa	630 MPa	26 %

Typical Charpy V-Notch Properties		
Condition	Testing Temperature	Impact Value
AWS		
PWHT 1 hour(s) 620 °C	-40 °C	104 J
PWHT 1 hour(s) 620 °C	-60 °C	65 J
ISO		
As Welded	-40 °C	140 J
As Welded	-60 °C	80 J

Typical Weld Metal Analysis %					
C	Mn	Si	Ni	Cr	Mo
0.06	1.77	0.27	0.9	0.03	0.01

FILARC 88S

Deposition Data					
Diameter	Current	Voltage	Efficiency (%)	Fusion time per electrode at 90% I max	Deposition Rate
2.5 x 350 mm	65-100 A	25.7 V	61 %	51 sec	0.96 kg/h
3.2 x 350 mm	90-150 A	23.1 V	40 %	67 sec	1.3 kg/h
4.0 x 450 mm	110-190 A	23.3 V	40 %	95 sec	1.59 kg/h
5.0 x 450 mm	185-235 A	24.9 V	40 %	110 sec	2.35 kg/h

FILARC 98S



All positional low hydrogen electrode for welding of higher strength steels, depositing weld metal with a minimum yield strength of 550 N/mm² after stress relieving.

Specifications	
Classifications	SFA/AWS A5.5 : E9018-G EN ISO 18275-A : E 55 6 Mn1NiMo B T 32 H5
Approvals	ABS : E9018-G CE : EN 13479 UKCA : EN 13479

Approvals are based on factory location. Please contact ESAB for more information.

Welding Current	AC, DC+-
Diffusible Hydrogen	< 5.0 ml/100g
Alloy Type	Low alloyed (0.9 % Ni, 0.3 % Mo)
Coating Type	Basic covering
Min AC OCV	65V

Typical Tensile Properties			
Condition	Yield Strength	Tensile Strength	Elongation
ISO			
PWHT 1 hour(s) 580 °C	650 MPa	710 MPa	21 %

Typical Charpy V-Notch Properties		
Condition	Testing Temperature	Impact Value
ISO		
PWHT 1 hour(s) 580 °C	-50 °C	80 J
PWHT 1 hour(s) 580 °C	-60 °C	60 J

Typical Weld Metal Analysis %					
C	Mn	Si	Ni	Cr	Mo
0.06	1.85	0.35	0.89	0.05	0.32

Deposition Data					
Diameter	Current	Voltage	Efficiency (%)	Fusion time per electrode at 90% I max	Deposition Rate
2.5 x 350 mm	55-85 A	24.4 V	60 %	60 sec	0.72 kg/h
3.2 x 350 mm	80-140 A	23.3 V	55 %	68 sec	0.94 kg/h
4.0 x 450 mm	120-180 A	24.0 V	60 %	103 sec	1.43 kg/h

OK 48.08



Basic universal electrode with very good welding characteristics, especially designed for welding of carbon steels, carbon manganese steels and fine grained carbon manganese steels with elevated yield strength. Typical field of application is offshore construction. The weld metal alloyed with approximately 0.9% Ni fulfills the requirements on impact toughness at -50°C. The coating is of low moisture absorption type and gives diffusible hydrogen < 4ml per 100 grams of weld metal. OK 48.08 is HIC test compliant as per NACE TM0284 & SSC test compliant as per NACE TM0177.

Specifications	
Classifications	SFA/AWS A5.5 : E7018-G H4R EN ISO 2560-A : E 46 5 1Ni B 32 H5
Approvals	ABS : 3Y H5 CE : EN 13479 DB : 10.039.31 DNV-GL : 4 Y40H5 LR : 4Y40 H5 UKCA : EN 13479 VdTÜV : 05778

Approvals are based on factory location. Please contact ESAB for more information.

Welding Current	AC, DC+(-)
Diffusible Hydrogen	< 4.0 ml/100g
Alloy Type	Low alloyed (0.9 % Ni)
Coating Type	Basic covering
Min AC OCV	65

Typical Tensile Properties			
Condition	Yield Strength	Tensile Strength	Elongation
AWS			
As welded (3G, V-UP)	530 MPa	610 MPa	-
ISO			
As Welded	540 MPa	630 MPa	26 %
PWHT 1 hour(s) 620 °C	480 MPa	550 MPa	26 %

Typical Charpy V-Notch Properties		
Condition	Testing Temperature	Impact Value
AWS		
As welded (3G, V-UP)	-50 °C	55 J
As welded (3G, V-UP)	-60 °C	50 J
ISO		
PWHT 1 hour(s) 620 °C	-46 °C	105 J
As Welded	-50 °C	85 J
As Welded	-60 °C	65 J

Typical Weld Metal Analysis %					
C	Mn	Si	Ni	Cr	Mo
0.06	1.2	0.35	0.95	0.02	0.001

OK 48.08

Deposition Data					
Diameter	Current	Voltage	Efficiency (%)	Fusion time per electrode at 90% I max	Deposition Rate
2.5 x 350 mm	65-110 A	20 V	60 %	57 sec	0.9 kg/h
3.2 x 350 mm	85-150 A	22 V	63 %	63 sec	1.3 kg/h
3.2 x 450 mm	85-150 A	22 V	63 %	64 sec	1.3 kg/h
4.0 x 450 mm	115-190 A	25 V	66 %	95 sec	1.8 kg/h
5.0 x 450 mm	155-280 A	28 V	66 %	93 sec	2.7 kg/h

OK 73.08



NiCu-alloyed electrode which deposits a weld metal with good corrosion resistance to sea water and flue gases, for the welding of weathering steels, e.g. Cor-Ten steel and ship's hull structural steel. The weld metal has excellent mechanical properties.

Specifications	
Classifications	SFA/AWS A5.5 : E8018-G EN ISO 2560-A : E 46 5 Z B 32
Approvals	ABS : 3Y H10 BV : 3Y H10 CE : EN 13479 DB : 10.039.20 DNV-GL : 3 YH10 LR : 3Y H10 RS : 3Y H10 VdTÜV : 02115

Approvals are based on factory location. Please contact ESAB for more information.

Welding Current	AC, DC+
Diffusible Hydrogen	< 10.0 ml/100g
Alloy Type	Low alloyed (0.7 % Ni, 0.4 % Cu)
Coating Type	Basic covering
Min AC OCV	65

Typical Tensile Properties			
Condition	Yield Strength	Tensile Strength	Elongation
ISO			
As Welded	520 MPa	610 MPa	30 %

Typical Charpy V-Notch Properties		
Condition	Testing Temperature	Impact Value
ISO		
As Welded	-50 °C	100 J

Typical Weld Metal Analysis %				
C	Mn	Si	Ni	Cu
0.06	1.1	0.4	0.7	0.4

Deposition Data					
Diameter	Current	Voltage	Efficiency (%)	Fusion time per electrode at 90° l max	Deposition Rate
2.5 x 350 mm	80-115 A	21 V	62 %	59 sec	0.9 kg/h
3.2 x 350 mm	100-150 A	23 V	62 %	68 sec	1.2 kg/h
3.2 x 450 mm	100-150 A	22 V	66 %	90 sec	1.3 kg/h
4.0 x 450 mm	130-200 A	23 V	68 %	100 sec	1.8 kg/h

OK 73.15



OK 73.15 is a basic electrode with very good welding characteristics. Its exceptional weldability is ideal for multiple applications including Pipe. The electrode has a classification of AWS 8018-C3 H4R and gives a weld metal alloyed with about 0.9% Ni. It fulfils impact requirements down to - 50 °C. The low moisture absorption coating gives less than 4 ml diffusible hydrogen / 100 g welded metal. Weld metal recovery is above 120 % for the main diameters. OK 73.15 is HIC test compliant as per NACE TM0284 & SSC test compliant as per NACE TM0177.

Specifications	
Classifications	SFA/AWS A5.5M : E5518-C3 SFA/AWS A5.5 : E8018-C3 H4R EN ISO 2560-A : E 46 5 1Ni B 4 2 H5
Approvals	CE : EN 13479 DNV-GL : 4 Y46H5 UKCA : EN 13479

Approvals are based on factory location. Please contact ESAB for more information.

Welding Current	DC+(-)
Diffusible Hydrogen	< 4.0 ml/100g
Alloy Type	Low alloyed (0.9 % Ni)
Coating Type	Basic covering

Typical Tensile Properties			
Condition	Yield Strength	Tensile Strength	Elongation
AWS			
As Welded	500 MPa	600 MPa	29 %
PWHT 10 hour(s) 620 °C	500 MPa	590 MPa	27 %
PWHT 1 hour(s) 620 °C	500 MPa	580 MPa	27 %
PWHT 6 hour(s) 620 °C	490 MPa	580 MPa	27 %

Typical Charpy V-Notch Properties		
Condition	Testing Temperature	Impact Value
AWS		
As Welded	-40 °C	90 J
PWHT 10 hour(s) 620 °C	-40 °C	70 J
As Welded	-50 °C	70 J
PWHT 10 hour(s) 620 °C	-50 °C	50 J
PWHT 1 hour(s) 620 °C	-50 °C	70 J
PWHT 6 hour(s) 620 °C	-50 °C	60 J
As Welded	-60 °C	60 J
PWHT 6 hour(s) 620 °C	-60 °C	50 J

Typical Weld Metal Analysis %									
C	Mn	Si	S	P	Ni	Cr	Mo	V	
0.07	1.10	0.35	0.014	0.009	0.90	0.08	0.15	0.01	

OK 73.15

Deposition Data					
Diameter	Current	Voltage	Efficiency (%)	Fusion time per electrode at 90% I max	Deposition Rate
2.5 x 350 mm	65-110 A	20 V	60 %	57 sec	0.9 kg/h
3.2 x 350 mm	85-150 A	22 V	63 %	63 sec	1.3 kg/h
3.2 x 450 mm	85-150 A	22 V	63 %	64 sec	1.3 kg/h
4.0 x 350 mm	115-190 A	25 V	65 %	93 sec	1.8 kg/h
4.0 x 450 mm	115-190 A	25 V	66 %	95 sec	1.8 kg/h
5.0 x 450 mm	155-280 A	28 V	66 %	93 sec	2.7 kg/h

OK 73.68



Nickel alloyed basic AC/DC electrode for welding low alloyed steels with impact requirements down to -60 C, e.g. in offshore/onshore applications. The electrode is CTOD-tested.

Specifications	
Classifications	SFA/AWS A5.5 : E8018-C1 EN ISO 2560-A : E 46 6 2Ni B 32 H5
Approvals	ABS : 3Y400 H5 BV : 5Y40M H5 CE : EN 13479 DNV-GL : 5 Y46H5 LR : 5Y42 H5 PRS : 5Y42 H5 UKCA : EN 13479 VdTUV : 01529

Approvals are based on factory location. Please contact ESAB for more information.

Welding Current	AC, DC+
Diffusible Hydrogen	< 5.0 ml/100g
Alloy Type	Low alloyed (2.5 % Ni)
Coating Type	Basic covering
Min AC OCV	65

Typical Tensile Properties			
Condition	Yield Strength	Tensile Strength	Elongation
AWS			
Stress Relieved 1 hour(s) 620 °C	500 MPa	600 MPa	28 %
ISO			
As Welded	540 MPa	635 MPa	25 %

Typical Charpy V-Notch Properties		
Condition	Testing Temperature	Impact Value
AWS		
Stress Relieved 1 hour(s) 620 °C	-60 °C	85 J
ISO		
As Welded	-20 °C	155 J
As Welded	-40 °C	117 J
As Welded	-60 °C	99 J

Typical Weld Metal Analysis %					
C	Mn	Si	Ni	Cr	Mo
0.05	1	0.35	2.4	0.02	0.01

Deposition Data					
Diameter	Current	Voltage	Efficiency (%)	Fusion time per electrode at 90% I max	Deposition Rate
2.5 x 350 mm	70-110 A	23 V	62 %	55 sec	0.9 kg/h

OK 73.68

Deposition Data

Diameter	Current	Voltage	Efficiency (%)	Fusion time per electrode at 90% I max	Deposition Rate
3.2 x 450 mm	105-150 A	23 V	62 %	81 sec	1.4 kg/h
4.0 x 450 mm	140-190 A	23 V	65 %	88 sec	2.0 kg/h
5.0 x 450 mm	190-270 A	27 V	65 %	104 sec	2.5 kg/h

OK 73.79



Nickel alloyed basic AC/DC low hydrogen electrode for MMA welding of 3.5 % Ni steels with impact requirements down to -101 °C, e.g. in LPG tanks for ethane, chemical plants etc.

Specifications

Classifications	SFA/AWS A5.5 : E8016-C2 EN ISO 2560-A : E 46 6 3 Ni B 12 H5
Approvals	DNV-GL : 5 Y46H5 RS : 5Y46 H5

Approvals are based on factory location. Please contact ESAB for more information.

Welding Current	AC, DC+-
Diffusible Hydrogen	< 5.0 ml/100g
Alloy Type	Low alloyed (3.5 % Ni)
Coating Type	Basic covering
Min AC OCV	65

Typical Tensile Properties

Condition	Yield Strength	Tensile Strength	Elongation
ISO			
As Welded	540 MPa	630 MPa	27 %

Typical Charpy V-Notch Properties

Condition	Testing Temperature	Impact Value
ISO		
As Welded	-60 °C	130 J
As Welded	-75 °C	110 J
As Welded	-101 °C	35 J

Typical Weld Metal Analysis %

C	Mn	Si	Ni	Cr	Mo
0.06	0.8	0.36	3.37	0.05	0.01

Deposition Data

Diameter	Current	Voltage	Efficiency (%)	Fusion time per electrode at 90% I max	Deposition Rate
2.5 x 350 mm	70-110 A	25 V	60 %	60 sec	0.8 kg/h
3.2 x 450 mm	80-150 A	25 V	60 %	77 sec	1.5 kg/h
4.0 x 450 mm	90-190 A	27 V	63 %	88 sec	1.8 kg/h
5.0 x 450 mm	110-240 A	29 V	60 %	100 sec	2.1 kg/h

OK 74.46



OK 74.46 is an LMA electrode alloyed with 0.5% Mo for welding steels for pressure vessels. The running characteristics make it suitable for welding joints in the inclined positions. The composition of the coating is adapted for welding with low currents, making it very suitable for the welding of pipes.

Specifications	
Classifications	SFA/AWS A5.5 : E7018-A1 EN ISO 3580-A : E Mo B 3 2 H5
Approvals	CE : EN 13479 DB : 10.039.45 VdTUV : 01043

Approvals are based on factory location. Please contact ESAB for more information.

Welding Current	AC, DC+
Diffusible Hydrogen	< 5ml/100g
Alloy Type	Low alloyed (0.5 % Mo)
Coating Type	Basic covering
Min AC OCV	65

Typical Tensile Properties			
Condition	Yield Strength	Tensile Strength	Elongation
ISO			
PWHT 1 hour(s) 620 °C	460 MPa	560 MPa	27 %

Typical Charpy V-Notch Properties		
Condition	Testing Temperature	Impact Value
ISO		
PWHT 1 hour(s) 620 °C	20 °C	175 J

Typical Weld Metal Analysis %				
C	Mn	Si	Cr	Mo
0.05	0.77	0.38	0.04	0.57

Deposition Data					
Diameter	Current	Voltage	Efficiency (%)	Fusion time per electrode at 90° I max	Deposition Rate
2.0 x 300 mm	55-80 A	22 V	59 %	40 sec	0.7 kg/h
2.5 x 350 mm	75-110 A	23 V	59 %	55 sec	0.9 kg/h
3.2 x 350 mm	105-150 A	23 V	54 %	66 sec	1.0 kg/h
3.2 x 450 mm	105-150 A	25 V	59 %	81 sec	1.2 kg/h
4.0 x 450 mm	140-200 A	26 V	65 %	90 sec	1.8 kg/h
5.0 x 450 mm	190-270 A	27 V	65 %	104 sec	2.4 kg/h

OK 74.70



OK 74.70 is used for welding high tensile low alloyed steels. The electrode is designed for welding different constructions including pipelines made from pipe steel in grades API 5LX60, 5LX65, 5LX70.

Specifications

Classifications	SFA/AWS A5.5 : E8018-G EN ISO 2560-A : E 50 4 Z B 42 H5
Welding Current	DC+(-)
Diffusible Hydrogen	< 5.0 ml/100g
Alloy Type	Low alloyed (0.5 % Mo)
Coating Type	Basic covering

Typical Tensile Properties

Condition	Yield Strength	Tensile Strength	Elongation
ISO			
As Welded	550 MPa	650 MPa	25 %

Typical Charpy V-Notch Properties

Condition	Testing Temperature	Impact Value
ISO		
As Welded	-20 °C	120 J
As Welded	-40 °C	90 J

Typical Weld Metal Analysis %

C	Mn	Si	Mo
0.08	1.5	0.4	0.45

Deposition Data

Diameter	Current	Voltage	Efficiency (%)	Fusion time per electrode at 90% I max	Deposition Rate
3.2 x 350 mm	80-140 A	23 V	58 %	63 sec	1.14 kg/h
3.2 x 450 mm	80-140 A	23 V	61 %	91 sec	1.6 kg/h
4.0 x 450 mm	110-190 A	24 V	63 %	93 sec	1.66 kg/h

OK 74.78



OK 74.78 is an LMA AC/DC electrode suitable for welding high tensile steels used in low temperature applications. Good notch toughness down to -40°C. Suitable for enclosed welding and cladding of rails, when a hardness of ~ 250 HV is required. Also suitable for butt welding rails with tensile strength of 800-900 N/mm². Due to low moisture content in the coating, this electrode is suitable when preheating cannot be applied.

Specifications

Classifications	SFA/AWS A5.5 : E9018-D1 EN ISO 18275-A : E 55 4 MnMo B 3 2 H5
Approvals	ABS : 3YQ460 H5 CE : EN 13479 DB : 81.039.02 DB : 82.039.02 DNV-GL : 3 Y46H5 VdTÜV : 01027

Approvals are based on factory location. Please contact ESAB for more information.

Welding Current	AC, DC+
Diffusible Hydrogen	< 5.0 ml/100g
Alloy Type	Low alloyed (0.4 % Mo)
Coating Type	Basic covering
Min AC OCV	65 V

Typical Tensile Properties

Condition	Yield Strength	Tensile Strength	Elongation
ISO			
As Welded	600 MPa	650 MPa	24 %

Typical Charpy V-Notch Properties

Condition	Testing Temperature	Impact Value
ISO		
As Welded	-40 °C	90 J
As Welded	-50 °C	70 J

Typical Weld Metal Analysis %

C	Mn	Si	Ni	Cr	Mo
0.05	1.60	0.35	0.03	0.03	0.35

Deposition Data

Diameter	Current	Voltage	Efficiency (%)	Fusion time per electrode at 90% I max	Deposition Rate
2.5 x 450 mm	105-140 A	23 V	65 %	86 sec	1.3 kg/h
4.0 x 450 mm	140-190 A	23 V	65 %	97 sec	1.8 kg/h
5.0 x 450 mm	190-260 A	24 V	68 %	100 sec	2.6 kg/h
6.0 x 350 mm	75-100 A	22 V	62 %	55 sec	0.9 kg/h

OK 74.86 TENSITRODE



A basic coated electrode for steels and castings with U.T.S of min 690 MPa.

Specifications

Classifications	SFA/AWS A5.5 : E10018-D2 EN ISO 18275-A : E 62 4 Mn1NiMo B T 32 H5
Approvals	ABS : 3YQ620 H5 CE : EN 13479 UKCA : EN 13479

Approvals are based on factory location. Please contact ESAB for more information.

Welding Current	AC, DC+
Diffusible Hydrogen	< 5.0 ml/100 g
Alloy Type	Low alloyed (1.8 % Mn, 0.4 % Mo)
Coating Type	Basic covering
Min AC OCV	65

Typical Tensile Properties

Condition	Yield Strength	Tensile Strength	Elongation
ISO			
Stress Relieved 1 hour(s) 590 °C	630 MPa	720 MPa	25 %

Typical Charpy V-Notch Properties

Condition	Testing Temperature	Impact Value
ISO		
Stress Relieved 1 hour(s) 590 °C	-40 °C	75 J
Stress Relieved 1 hour(s) 590 °C	-50 °C	60 J

Typical Weld Metal Analysis %

C	Mn	Si	Ni	Cr	Mo
0.06	1.74	0.37	0.83	0.04	0.34

Deposition Data

Diameter	Current	Voltage	Efficiency (%)	Fusion time per electrode at 90° l max	Deposition Rate
2.5 x 350 mm	75-100 A	21.6 V	61 %	60.1 sec	0.86 kg/h
3.2 x 350 mm	110-140 A	23 V	63 %	63 sec	1.35 kg/h
3.2 x 450 mm	110-140 A	22 V	65 %	85.6 sec	1.2 kg/h
4.0 x 450 mm	150-190 A	22.8 V	62 %	93.4 sec	1.72 kg/h
5.0 x 450 mm	190-260 A	22.8 V	68 %	92.6 sec	2.72 kg/h

OK 75.75



OK 75.75 is an LMA electrode dried to a low moisture content and suitable for the welding of high-strength, low-alloyed steels, at room temperature or with moderate preheating.

Specifications	
Classifications	SFA/AWS A5.5 : E11018-G EN ISO 18275-A : E 69 4 Mn2NiCrMo B 42 H5
Approvals	ABS : E11018-G CE : EN 13479 DB : 10.039.19 VdTÜV : 01028

Approvals are based on factory location. Please contact ESAB for more information.

Welding Current	DC+
Diffusible Hydrogen	< 5.0 ml/100g
Alloy Type	Low alloyed (2.4 % Ni, 0.4 % Cr, 0.4 % Mo)
Coating Type	Basic covering

Typical Tensile Properties			
Condition	Yield Strength	Tensile Strength	Elongation
ISO			
As Welded	780 MPa	830 MPa	20 %

Typical Charpy V-Notch Properties		
Condition	Testing Temperature	Impact Value
ISO		
As Welded	-40 °C	60 J

Typical Weld Metal Analysis %					
C	Mn	Si	Ni	Cr	Mo
0.05	1.61	0.36	2.4	0.4	0.4

Deposition Data					
Diameter	Current	Voltage	Efficiency (%)	Fusion time per electrode at 90% I max	Deposition Rate
2.5 x 350 mm	70-110 A	22 V	67 %	54 sec	1.0 kg/h
3.2 x 450 mm	100-150 A	23 V	67 %	80 sec	1.4 kg/h
4.0 x 450 mm	135-200 A	24 V	65 %	92 sec	1.9 kg/h
5.0 x 450 mm	180-260 A	25 V	63 %	105 sec	2.5 kg/h

OK 75.78



This electrode is tailored for steels with very high tensile strength. The electrode gives tensile strength over 900 N/mm² and impact values over 47 J at -60 °C.

Specifications

Classifications	EN ISO 18275-A : E 89 6 Z B 32 H5
Welding Current	AC, DC+
Diffusible Hydrogen	4.0 ml/100g
Alloy Type	CrNiMo
Coating Type	Basic
Min AC OCV	65

Typical Tensile Properties

Condition	Yield Strength	Tensile Strength	Elongation
ISO			
As Welded	922 MPa	974 MPa	19 %

Typical Charpy V-Notch Properties

Condition	Testing Temperature	Impact Value
ISO		
As Welded	-60 °C	47 J

Typical Weld Metal Analysis %

C	Mn	Si	Ni	Cr	Mo
0.052	1.91	0.30	3.23	0.52	0.63

Deposition Data

Diameter	Current	Voltage	Efficiency (%)	Fusion time per electrode at 90% I max	Deposition Rate
2.5 x 350 mm	70-110 A	24 V	61 %	52 sec	0.9 kg/h
3.2 x 350 mm	110-150 A	24 V	63 %	77 sec	1.4 kg/h
4.0 x 450 mm	150-200 A	24 V	65 %	86 sec	1.9 kg/h

OK 76.18



Basic DC electrode for welding creep resisting steels of the type 1% Cr 0.5% Mo. Welds with a stable arc and minimum spatter. Deposits weld metal resistant to both cracking and porosity.

Specifications	
Classifications	SFA/AWS A5.5 : E8018-B2 EN ISO 3580-A : E CrMo1 B 4 2 H5
Approvals	ABS : SR H5 BV : Welding of low alloy steels type 1%Cr 0.5%Mo, H5 CE : EN 13479 DNV-GL : -H5 UKCA : EN 13479 VdTUV : 01387

Approvals are based on factory location. Please contact ESAB for more information.

Welding Current	DC+(-)
Diffusible Hydrogen	< 5ml/100g
Alloy Type	Low alloyed (1.25 % Cr ; 0.5 % Mo)
Coating Type	Basic covering

Typical Tensile Properties			
Condition	Yield Strength	Tensile Strength	Elongation
ISO			
PWHT 1 hour(s) 690 °C	580 MPa	670 MPa	24 %

Typical Charpy V-Notch Properties		
Condition	Testing Temperature	Impact Value
ISO		
PWHT 1 hour(s) 690 °C	20 °C	100 J

Typical Weld Metal Analysis %				
C	Mn	Si	Cr	Mo
0.06	0.7	0.3	1.3	0.5

Deposition Data					
Diameter	Current	Voltage	Efficiency (%)	Fusion time per electrode at 90% I max	Deposition Rate
2.0 x 300 mm	55-80 A	22 V	58 %	40 sec	0.7 kg/h
2.5 x 300 mm	70-110 A	24 V	58 %	52 sec	0.8 kg/h
3.2 x 350 mm	95-150 A	25 V	59 %	65 sec	1.1 kg/h
4.0 x 450 mm	130-190 A	27 V	64 %	90 sec	1.7 kg/h
5.0 x 450 mm	150-260 A	28 V	64 %	95 sec	2.7 kg/h

OK 76.28



Basic DC electrode for welding creep-resisting steels of the type 2.25 % Cr and 1 % Mo.

Specifications	
Classifications	SFA/AWS A5.5 : E9018-B3 EN ISO 3580-A : E CrMo2 B 4 2 H5
Approvals	BV : C2M1 H5 CE : EN 13479 UKCA : EN 13479 VdTUV : 00971

Approvals are based on factory location. Please contact ESAB for more information.

Welding Current	DC+(-)
Diffusible Hydrogen	< 5ml/100g
Alloy Type	Low alloyed (2.2 % Cr ; 1,1 % Mo)
Coating Type	Basic covering

Typical Tensile Properties			
Condition	Yield Strength	Tensile Strength	Elongation
ISO			
PWHT 1 hour(s) 690 °C	630 MPa	720 MPa	21 %

Typical Charpy V-Notch Properties		
Condition	Testing Temperature	Impact Value
ISO		
PWHT 1 hour(s) 690 °C	20 °C	130 J

Typical Weld Metal Analysis %				
C	Mn	Si	Cr	Mo
0.06	0.7	0.3	2.2	1.1

Deposition Data					
Diameter	Current	Voltage	Efficiency (%)	Fusion time per electrode at 90% I max	Deposition Rate
2.5 x 300 mm	70-110 A	25 V	58 %	52 sec	0.8 kg/h
3.2 x 350 mm	95-150 A	26 V	59 %	62 sec	1.2 kg/h
4.0 x 450 mm	130-190 A	28 V	64 %	88 sec	1.8 kg/h
5.0 x 450 mm	150-260 A	29 V	64 %	92 sec	2.7 kg/h
6.0 x 450 mm	200-350 A	30 V	64 %	90 sec	3.9 kg/h

OK 76.35



Basic DC electrode for welding heat resisting CrMo steel plate or tubes of the type 5 % Cr and 0.5 % Mo.

Specifications

Classifications	SFA/AWS A5.5 : E8015-B6 H4 R EN ISO 3580-A : E CrMo5 B 4 2 H5
Welding Current	DC+-
Diffusible Hydrogen	< 4.0 ml/100g
Alloy Type	Low alloyed (5 % Cr ; 0.5 % Mo)
Coating Type	Basic covering

Typical Tensile Properties

Condition	Yield Strength	Tensile Strength	Elongation
ISO			
PWHT 1 hour(s) 750 °C	500 MPa	620 MPa	22 %

Typical Charpy V-Notch Properties

Condition	Testing Temperature	Impact Value
ISO		
PWHT 1 hour(s) 750 °C	20 °C	110 J

Typical Weld Metal Analysis %

C	Mn	Si	Ni	Cr	Mo
0.05	0.7	0.4	0.03	5	0.55

Deposition Data

Diameter	Current	Voltage	Efficiency (%)	Fusion time per electrode at 90° I max	Deposition Rate
2.0 x 300 mm	50-70 A	23 V	57 %	53 sec	0.49 kg/h
2.5 x 300 mm	65-95 A	23 V	57 %	63 sec	0.7 kg/h
3.2 x 350 mm	90-130 A	24 V	56 %	70 sec	1.0 kg/h
4.0 x 450 mm	125-165 A	24 V	58 %	80 sec	1.3 kg/h

OK 76.96



OK 76.96 is an LMA electrode containing 9Cr 1Mo for the welding of creep-resistant steels . It is especially suitable for pipe welding. The electrode runs with a quiet , stable arc and give a minimum amount of spatter. A preheating and interpass temperature of 150-269 C is normally required .

Specifications

Classifications	SFA/AWS A5.5 : E8015-B8 EN ISO 3580-A : E (CrMo9) B 4 2 H5
Welding Current	DC+
Diffusible Hydrogen	<5ml/100g
Alloy Type	Creep resisting
Coating Type	Lime Basic

Typical Tensile Properties

Condition	Yield Strength	Tensile Strength	Elongation
ISO			
Stress Relieved 2 hour(s) 650 °C	730 MPa	850 MPa	17 %
Stress Relieved 2 hour(s) 750 °C	550 MPa	720 MPa	22 %

Typical Charpy V-Notch Properties

Condition	Testing Temperature	Impact Value
ISO		
Stress Relieved 2 hour(s) 750 °C	20 °C	60 J
Stress Relieved 2 hour(s) 850 °C	20 °C	80 J
Stress Relieved 2 hour(s) 650 °C	20 °C	25 J

Typical Weld Metal Analysis %

C	Mn	Si	Ni	Cr	Mo	Cu	Nb
0.07	0.8	0.4	0.02	8.8	1.05	0.03	0.003

Deposition Data

Diameter	Current	Voltage	Efficiency (%)	Fusion time per electrode at 90% I max	Deposition Rate
2.5 x 300 mm	70-100 A	25 V	55 %	51 sec	0.8 kg/h
3.2 x 350 mm	90-135 A	26 V	55 %	70 sec	1.1 kg/h
4.0 x 450 mm	130-200 A	21 V	64 %	80 sec	1.9 kg/h

OK 76.98



OK 76.98 is a low-hydrogen electrode for welding of modified 9 Cr-steels like T91/P91. The electrode is suitable for all-positional welding in pipes and plates.

Specifications	
Classifications	SFA/AWS A5.5 : E9015-B91 (nearest) EN ISO 3580-A : E CrMo91 B 4 2 H5
Approvals	CE : EN 13479 UKCA : EN 13479 VdTÜV : 07687

Approvals are based on factory location. Please contact ESAB for more information.

Welding Current	DC+
Diffusible Hydrogen	< 5.0 ml/100g
Alloy Type	Low alloyed (9 % Cr, 1 % Mo + Ni / V / Nb)
Coating Type	Basic covering

Typical Tensile Properties			
Condition	Yield Strength	Tensile Strength	Elongation
ISO			
PWHT 2 hour(s) 755 °C	720 MPa	820 MPa	21 %

Typical Charpy V-Notch Properties		
Condition	Testing Temperature	Impact Value
ISO		
PWHT 2 hour(s) 755 °C	20 °C	50 J

Typical Weld Metal Analysis %							
C	Mn	Si	Ni	Cr	Mo	V	Nb
0.1	0.8	0.35	0.7	9	1	0.24	0.06

Deposition Data					
Diameter	Current	Voltage	Efficiency (%)	Fusion time per electrode at 90% I max	Deposition Rate
2.5 x 350 mm	70-100 A	21 V	66 %	56 sec	0.9 kg/h
3.2 x 350 mm	90-135 A	22 V	60 %	68 sec	1.2 kg/h
4.0 x 450 mm	130-200 A	23 V	64 %	85 sec	1.9 kg/h
5.0 x 450 mm	140-260 A	22 V	65 %	110 sec	2.3 kg/h

OK 78.16



OK 78.16 is a CrMo-alloyed electrode for the welding of 0.25C-1Cr-0.3Mo-alloyed quenched and tempered steel grades. The heat treatment requirements for the weld metal are the same as those for the parent plate. The weld metal of OK 78.16 is also suitable for flame hardening. The welding of high tensile strength steel with OK 78.16 should be carried out at a preheating temperature of minimum 200°C.

Specifications

Classifications	SFA/AWS A5.5 : E9018-G EN ISO 18275-A : E 69 A Z B 42
Approvals	CE : EN 13479

Approvals are based on factory location. Please contact ESAB for more information.

Welding Current	DC+
Alloy Type	Low alloyed (1.15 % Cr ; 0.2 % Mo)
Coating Type	Basic covering

Typical Tensile Properties

Condition	Yield Strength	Tensile Strength	Elongation
ISO			
As Welded	800 MPa	900 MPa	17 %

Typical Charpy V-Notch Properties

Condition	Testing Temperature	Impact Value
ISO		
As Welded	20 °C	80 J

Typical Weld Metal Analysis %

C	Mn	Si	Cr	Mo
0.17	0.76	0.52	1.15	0.2

Deposition Data

Diameter	Current	Voltage	Efficiency (%)	Fusion time per electrode at 90% I max	Deposition Rate
2.5 x 450 mm	105-140 A	21 V	64 %	78 sec	1.4 kg/h
4.0 x 450 mm	145-195 A	22 V	66 %	83 sec	1.9 kg/h
5.0 x 450 mm	190-260 A	23 V	68 %	86 sec	2.8 kg/h

OK B2 SC



OK B2 SC is a basic AC/DC electrode designed for welding of creep resistant 1.25% Cr 0.5% Mo alloyed steels, SA-387 Grade 11, SA-182 Grade 11, SA-335 Grade P11 or similar materials when highest toughness values are required also after step cooling treatment. Very low level of impurity elements providing a X-bar max. 10 for temper embrittlement resistant applications. Usually welding is followed by a PWHT. Suitable for refinery, petrochemical and chemical industries, power generation, pressure vessels, etc.

Specifications	
Classifications	SFA/AWS A5.5 : E8018-B2-H4R EN ISO 3580-A : E CrMo1B 42 H5
Approvals	CE : EN 13749 VdTÜV : 19549

Approvals are based on factory location. Please contact ESAB for more information.

Welding Current	DC+-, AC
Diffusible Hydrogen	< 4.0 ml/100g
Alloy Type	Low alloyed (1.25% Cr, 0.5% Mo)
Coating Type	Basic covering
Min AC OCV	65

Typical Tensile Properties				
Condition	Conditional Statement	Yield Strength	Tensile Strength	Elongation
PWHT 1 hour(s) 690 °C	-	505 MPa	605 MPa	22 %
AWS				
1.PWHT 1 hour(s) 690 °C	-	510 MPa	605 MPa	25 %
2.PWHT 2 hour(s) 690 °C	-	490 MPa	590 MPa	27 %
3.PWHT 22 hour(s) 690 °C	-	460 MPa	555 MPa	30 %
4.PWHT (Test)	Test temp. 450°C	370 MPa	470 MPa	22 %

Typical Charpy V-Notch Properties		
Condition	Testing Temperature	Impact Value
PWHT 1 hour(s) 690 °C	20 °C	180 J
AWS		
1.PWHT 1 hour(s) 690 °C	-30 °C	155 J
2.PWHT 2 hour(s) 690 °C	-30 °C	150 J
3.PWHT 22 hour(s) 690 °C	-30 °C	160 J

Typical Weld Metal Analysis %									
C	Mn	Si	S	P	Ni	Cr	Mo	V	Al
0.08	0.75	0.20	0.004	0.005	0.04	1.25	0.55	0.008	0.002

OK B2 SC

Typical Weld Metal Analysis %

Cu	Nb	Ti	Sb	As	B	Sn	Mn+Si	Nb+Ti+V	P+Sn
0.02	0.003	0.006	0.001	0.002	0.0002	0.003	1.0	0.015	0.008

Typical Weld Metal Analysis %

PE	J-Factor	X-bar
2.6	80	7

Deposition Data

Diameter	Current	Voltage	Efficiency (%)	Fusion time per electrode at 90% I max	Deposition Rate
2.5 x 350 mm	70-110 A	25 V	58 %	60 sec	0.79 kg/h
3.2 x 350 mm	95-150 A	23 V	63 %	64 sec	1.2 kg/h
4.0 x 350 mm	120-190 A	22 V	63 %	77 sec	1.6 kg/h
4.0 x 450 mm	120-190 A	23 V	66 %	91 sec	1.8 kg/h
5.0 x 450 mm	150-260 A	23 V	63 %	108 sec	2.3 kg/h

OK B3 SC



OK B3 SC is a basic AC/DC electrode designed for welding of creep resistant 2.25% Cr 1% Mo alloyed steels, SA-387 Grade 22, A335 Grade P22 or similar materials when highest toughness values are required also after step cooling treatment. Very low level of impurity elements providing a X-bar max. 10 for temper embrittlement resistant applications. Usually welding is followed by a PWHT. Suitable for refinery, petrochemical and chemical industries, power generation, pressure vessels, etc.

Specifications	
Classifications	SFA/AWS A5.5 : E9018-B3 H4 R EN ISO 3580-A : E CrMo2 B 32 H5
Approvals	CE : EN 13479 UKCA : EN 13479 VdTUV : 19612

Approvals are based on factory location. Please contact ESAB for more information.

Welding Current	DC+-, AC
Diffusible Hydrogen	Max 4 ml /100 g
Alloy Type	Low alloyed (2.25% Cr ; 1% Mo)
Coating Type	Basic covering
Min AC OCV	65

Typical Tensile Properties				
Condition	Conditional Statement	Yield Strength	Tensile Strength	Elongation
AWS				
1.PWHT 1 hour(s) 690 °C	-	550 MPa	650 MPa	23 %
2.PWHT 4 hour(s) 690 °C	-	540 MPa	650 MPa	25 %
3.PWHT 32 hour(s) 690 °C	-	460 MPa	580 MPa	27 %
4.PWHT (Test	Test Temp. 454°C	370 MPa	455 MPa	18 %

Typical Charpy V-Notch Properties		
Condition	Testing Temperature	Impact Value
AWS		
1.PWHT 1 hour(s) 690 °C	-30 °C	120 J
2.PWHT 4 hour(s) 690 °C	-30 °C	150 J
3.PWHT 32 hour(s) 690 °C	-30 °C	140 J

Typical Weld Metal Analysis %									
C	Mn	Si	S	P	Ni	Cr	Mo	V	Al
0.085	0.7	0.20	0.004	0.005	0.04	2.35	1	0.007	0.002

Typical Weld Metal Analysis %									
Cu	Nb	Ti	Sb	As	B	Sn	Mn+Si	Nb+Ti+V	P+Sn
0.04	0.004	0.007	0.001	0.002	0.0002	0.004	0.9	0.018	0.009

OK B3 SC

Typical Weld Metal Analysis %

PE	J-Factor	X-bar
2.7	85	7

Deposition Data

Diameter	Current	Voltage	Efficiency (%)	Fusion time per electrode at 90% I max	Deposition Rate
2.5 x 350 mm	60-95 A	23 V	60 %	63 sec	0.8 kg/h
3.2 x 350 mm	75-145 A	23 V	60 %	62 sec	1.2 kg/h
4.0 x 450 mm	100-200 A	26 V	58 %	86 sec	1.7 kg/h
5.0 x 450 mm	115-260 A	25 V	63 %	106 sec	2.3 kg/h

Pipeweld 90DH



A low alloyed low hydrogen electrode of AWS E9045-P2 type specially designed for downhill welding circumferential joints in pipelines API 5L X70,X80. The low hydrogen weld metal provides high notch toughness and excellent ductility to reduce the risk of cracking. The electrode has been specially designed to provide excellent striking properties and elimination of start porosity. Productivity is significantly higher than conventional low hydrogen electrodes for welding vertically up.

Specifications

Classifications	SFA/AWS A5.5 : E9045-P2 H4R EN ISO 18275-A : E 55 6 Mn1Ni B 45 H5
Welding Current	DC+
Diffusible Hydrogen	<4.0 ml/100g
Alloy Type	Low alloyed
Coating Type	Basic

Typical Tensile Properties

Condition	Yield Strength	Tensile Strength	Elongation
ISO			
As Welded	590 MPa	670 MPa	24 %

Typical Charpy V-Notch Properties

Condition	Testing Temperature	Impact Value
ISO		
As Welded	-30 °C	80 J
As Welded	-60 °C	50 J

Typical Weld Metal Analysis %

C	Mn	Si	Ni
0.07	1.5	0.5	0.8

Deposition Data

Diameter	Current	Voltage	Efficiency (%)	Fusion time per electrode at 90% I max	Deposition Rate
2.5 x 350 mm	70-100 A	21 V	70 %	58 sec	1.0 kg/h
3.2 x 350 mm	110-150 A	21 V	68 %	56 sec	1.5 kg/h
4.0 x 350 mm	180-220 A	24 V	67 %	54 sec	2.3 kg/h

OK Pipeweld 7010 Plus



Cellulosic coated electrode for welding of low alloy steel pipes. Designed for vertical down welding, the deep penetrating arc provides good performance. Suitable for welding pipe steel types API 5L X52 to X60.

Specifications

Classifications	SFA/AWS A5.5 : E7010-P1 EN ISO 2560-A : E 42 2 Z C 21
Approvals	FBTS : E 7010-P1

Approvals are based on factory location. Please contact ESAB for more information.

Welding Current	DC+
Alloy Type	Low alloyed (0.3 % Ni, 0.2 % Mo)
Coating Type	Cellulosic covering

Typical Tensile Properties

Condition	Yield Strength	Tensile Strength	Elongation
AWS			
As Welded	480 MPa	570 MPa	22 %

Typical Charpy V-Notch Properties

Condition	Testing Temperature	Impact Value
AWS		
As Welded	-20 °C	55 J
As Welded	-30 °C	45 J

Typical Weld Metal Analysis %

C	Mn	Si	Ni	Mo
0.09	0.46	0.12	0.34	0.24

Deposition Data

Diameter	Current	Voltage	Efficiency (%)	Fusion time per electrode at 90% I max	Deposition Rate
3.2 x 350 mm	65-120 A	31 V	58 %	90 sec	0.62 kg/h
4.0 x 350 mm	90-180 A	30.5 V	59 %	93 sec	0.93 kg/h
5.0 x 350 mm	150-240 A	28.6 V	67 %	100 sec	1.47 kg/h

PIPEWELD 8010 PLUS



Cellulosic coated electrode designed for low alloy steel. Deep penetration welding in all positions, especially designed for vertical down welding of high strength pipelines. Provides high economic benefits compared to welding vertical up. Recommended for welding pipe-lines of API 5LX: X60- X70.

Specifications

Classifications	SFA/AWS A5.5 : E8010-P1 EN ISO 2560-A : E 46 2 Z C 21
Welding Current	DC+
Alloy Type	Low alloyed (0.3 % Ni, 0.25 % Mo)
Coating Type	Cellulosic covering

Typical Tensile Properties

Condition	Yield Strength	Tensile Strength	Elongation
AWS			
As Welded	530 MPa	620 MPa	23 %

Typical Charpy V-Notch Properties

Condition	Testing Temperature	Impact Value
AWS		
As Welded	-30 °C	40 J

Typical Weld Metal Analysis %

C	Mn	Si	Ni	Cr	Mo
0.09	0.4	0.10	0.4	0.021	0.31

Deposition Data

Diameter	Current	Voltage	Efficiency (%)	Fusion time per electrode at 90% I max	Deposition Rate
3.2 x 350 mm	65-120 A	30 V	62 %	86 sec	0.68 kg/h
4.0 x 350 mm	90-180 A	29 V	68 %	84 sec	1.15 kg/h

PIPEWELD 9010 PLUS



Cellulosic coated electrode designed for low alloy steel. Deep penetration welding in all positions, especially in the vertical downward ; recommended for welding pipe-lines of API 5LX: X70- X80.

Specifications

Classifications	SFA/AWS A5.5 : E9010-P1 EN ISO 2560-A : E 50 2 1NiMo C 21
Approvals	FBTS : E 9010-P1

Approvals are based on factory location. Please contact ESAB for more information.

Welding Current	DC+
Alloy Type	Low alloyed (0.9 % Ni, 0.4 % Mo)
Coating Type	Cellulosic covering

Typical Tensile Properties

Condition	Yield Strength	Tensile Strength	Elongation
AWS			
As Welded	620 MPa	700 MPa	22 %

Typical Charpy V-Notch Properties

Condition	Testing Temperature	Impact Value
AWS		
As Welded	-20 °C	60 J
As Welded	-30 °C	35 J

Typical Weld Metal Analysis %

C	Mn	Si	Ni	Mo
0.10	1.00	0.20	0.90	0.40

Deposition Data

Diameter	Current	Voltage	Efficiency (%)	Fusion time per electrode at 90% I max	Deposition Rate
3.2 x 350 mm	65-120 A	32 V	63 %	79 sec	0.82 kg/h
4.0 x 350 mm	90-180 A	34 V	63 %	78 sec	1.17 kg/h

OK AristoRod 13.08

The non copper coated OK AristoRod 13.08 is a ER80S-D2 classified, manganese-molybdenum (1,6% Mn, 0,4% Mo), solid wire for GMAW of creep resistant steels of the same type, such as pipes in pressure vessels and boilers with a working temperature of up to 500 C. The AristoRod wires are suitable for operating at high currents with maintained disturbance free wire feeding giving a stable arc with a low amount of spatter. OK AristoRod 13.08 delivered in the unique Esab Octagonal Marathon Pac is excellent in mechanised welding applications.

Specifications	
Classifications	EN ISO 14341-A : G 46 0 C1 4Mo EN ISO 14341-A : G 50 4 M21 4Mo EN ISO 14341-A : G 4Mo SFA/AWS A5.28 : ER80S-D2 CAN/CSA-ISO 14341 : B-G 55A 3 C1 S4M31

Alloy Type	Low alloyed (1.6 % Mn, 0.4 % Mo)
Shielding Gas	M21, C1 (EN ISO 14175)

Typical Tensile Properties			
Condition	Yield Strength	Tensile Strength	Elongation
EN 80Ar/20CO2 (M21)			
As Welded	590 MPa	685 MPa	24 %
AWS CO2 (C1)			
As Welded	540 MPa	645 MPa	25 %

Typical Charpy V-Notch Properties		
Condition	Testing Temperature	Impact Value
EN 80Ar/20CO2 (M21)		
As Welded	20 °C	140 J
As Welded	-20 °C	100 J
As Welded	-40 °C	80 J
AWS CO2 (C1)		
As Welded	20 °C	90 J
As Welded	-20 °C	36 J
As Welded	-40 °C	38 J

Typical Weld Metal Analysis %							
C	Mn	Si	S	P	Ni	Mo	Cu
0.07	1.6	0.5	0.01	0.01	0.05	0.4	0.15

Typical Wire Composition %					
C	Mn	Si	Ni	Cr	Mo
0.098	1.78	0.6	0.05	0.04	0.47

Deposition Data				
Diameter	Current	Voltage	Wire Feed Speed	Deposition Rate
1.0 mm	90-300 A	18-28 V	2.7-14.7 m/min	1.0-5.4 kg/h
1.2 mm	120-350 A	20-33 V	2.7-12.4 m/min	1.5-6.6 kg/h

OK AristoRod 13.09

The non copper coated OK AristoRod 13.09 is a low-alloyed, molybdenum (0,5% Mo), solid wire for GMAW of creep resistant steels of the same type, such as pipes in pressure vessels and boilers with a working temperature of up to 500 °C. The AristoRod wires are suitable for operating at high currents with maintained disturbance free wire feeding giving a stable arc with a low amount of spatter. OK AristoRod 13.09 delivered in the unique Esab Octagonal Marathon Pac is excellent in mechanised welding applications.

Specifications

Classifications	EN ISO 14341-A : G 38 0 C1 2Mo EN ISO 14341-A : G 46 2 M21 2Mo EN ISO 14341-A : G 2Mo EN ISO 21952-A : G MoSi EN ISO 21952-B : G 1M3 SFA/AWS A5.28 : ER70S-A1 (ER80S-G)
Approvals	CE : EN 13479 DB : 42.039.31 DNV-GL : III YMS (M21) UKCA : EN 13479 VdTUV : 10088

Approvals are based on factory location. Please contact ESAB for more information.

Alloy Type	Low alloyed (0.5 % Mo)
Shielding Gas	M21, C1 (EN ISO 14175)

Typical Tensile Properties

Condition	Conditional Statement	Yield Strength	Tensile Strength	Elongation
M21				
As Welded	Tested at 450°C	515 MPa	630 MPa	26 %
As Welded+	Tested at 450°C	425 MPa	570 MPa	20 %
Stress Relieved 15 hour(s) 620 °C	Tested at 450°C	430 MPa	545 MPa	26 %
Stress relieved+ 15 hour(s) 620 °C	Tested at 450°C	370 MPa	490 MPa	23 %

Typical Charpy V-Notch Properties

Condition	Testing Temperature	Impact Value
M21		
As Welded	20 °C	117 J
Stress Relieved 15 hour(s) 620 °C	20 °C	150 J
Stress Relieved 15 hour(s) 620 °C	0 °C	130 J
As Welded	-20 °C	75 J
Stress Relieved 15 hour(s) 620 °C	-20 °C	95 J
As Welded	-40 °C	57 J
Stress Relieved 15 hour(s) 620 °C	-40 °C	90 J

Typical Weld Metal Analysis %

C	Mn	Si	S	P	Mo
C1					
0.09	1.0	0.65	0.015	0.010	0.45
M21					

OK AristoRod 13.09

Typical Weld Metal Analysis %

C	Mn	Si	S	P	Mo
0.1	1.1	0.7	0.015	0.010	0.5

Typical Wire Composition %

C	Mn	Si	Ni	Cr	Mo
0.094	1.09	0.61	0.04	0.07	0.45

Deposition Data

Diameter	Current	Voltage	Wire Feed Speed	Deposition Rate
0.8 mm	40-170 A	16-22 V	2.0-10.8 m/min	0.4-2.6 kg/h
1.0 mm	80-280 A	18-28 V	2.7-14.7 m/min	1.0-5.4 kg/h
1.2 mm	120-350 A	20-33 V	2.7-12.4 m/min	1.5-6.6 kg/h

OK AristoRod 13.12

The non copper coated OK AristoRod 13.12 is a low-alloyed, chromium-molybdenum (1,1% Cr, 0,5% Mo), solid wire for GMAW of creep resistant steels of similar composition. Suitable for service temperatures up to 450 C. The AristoRod wires are suitable for operating at high currents with maintained disturbance free wire feeding giving a stable arc with a low amount of spatter. OK AristoRod 13.12 delivered in the unique Esab Octagonal Marathon Pac is excellent in mechanised welding applications.

Specifications

Classifications	EN ISO 21952-A : G CrMo1Si EN ISO 21952-B : G 55M 1CM3 SFA/AWS A5.28 : ER80S-G GOST 2246 : 08X CM A
Approvals	VdTÜV : 10089

Approvals are based on factory location. Please contact ESAB for more information.

Alloy Type	Low Alloyed (1 % Cr, 0,5 % Mo)
-------------------	--------------------------------

Typical Tensile Properties

Condition	Yield Strength	Tensile Strength	Elongation
EN 80Ar/20CO2 (M21)			
As Welded	640 MPa	740 MPa	18 %
As Welded+	605 MPa	760 MPa	15 %
PWHT 0.5 hour(s) 700 °C	450 MPa	580 MPa	24 %
Q.T. 15 hour(s) 940+730 °C	320 MPa	460 MPa	35 %
Q.T.+ 15 hour(s) 940+730 °C	210 MPa	410 MPa	25 %
Stress Relieved 1 hour(s) 690 °C	500 MPa	610 MPa	26 %
Stress relieved++ 0.5 hour(s) 700 °C	390 MPa	500 MPa	17 %

Typical Charpy V-Notch Properties

Condition	Testing Temperature	Impact Value
EN 80Ar/20CO2 (M21)		
As Welded	20 °C	90 J
Q.T. 15 hour(s) 940+730 °C	20 °C	115 J
Stress Relieved 1 hour(s) 690 °C	20 °C	130 J
As Welded	0 °C	80 J
Q.T. 15 hour(s) 940+730 °C	0 °C	60 J
As Welded	-20 °C	60 J
Q.T. 15 hour(s) 940+730 °C	-20 °C	30 J
Stress Relieved 1 hour(s) 690 °C	-20 °C	90 J
As Welded	-40 °C	30 J
Stress Relieved 1 hour(s) 690 °C	-40 °C	80 J

OK AristoRod 13.12

Typical Weld Metal Analysis %

C	Mn	Si	S	P	Cr	Mo
CO₂						
0.09	1.0	0.6	0.015	0.010	1.1	0.5
80Ar/20CO₂						
0.1	1.0	0.7	0.015	0.010	1.1	0.5

Typical Wire Composition %

C	Mn	Si	Ni	Cr	Mo
0.11	1.00	0.65	0.02	1.18	0.42

Deposition Data

Diameter	Current	Voltage	Wire Feed Speed	Deposition Rate
0.8 mm	80-280 A	18-28 V	2.7-14.7 m/min	1.0-5.4 kg/h
1.0 mm	80-280 A	18-28 V	2.7-14.7 m/min	1.0-5.4 kg/h
1.2 mm	120-350 A	20-33 V	2.7-12.4 m/min	1.5-6.6 kg/h
1.6 mm	225-480 A	26-38 V	3.1-12.0 m/min	3.3-11.6 kg/h

OK AristoRod 13.16

OK AristoRod 13.16 is a low-alloyed, chromium-molybdenum (1,3% Cr, 0,5% Mo) ER80S-B2, solid wire for GMAW of creep resistant steels like SA-387 Grade 11, A 335 Grade P11 or similar materials. OK AristoRod 13.16 is a high purity wire with a guaranteed Bruscato factor X<15. It is treated with ESAB's unique advanced surface characteristics (ASC) technology, taking MAG welding operations to new levels of performance and all-round efficiency, especially in robotic and mechanised welding. Characteristics features include excellent start properties; trouble free feeding at high wire speeds and lengthy feed distances; a very stable arc at high welding currents; extremely low levels of spatter; low fume emission; reduced contact tip wear and improved protection against corrosion of the wire.

Specifications	
Classifications	EN ISO 21952-A : G Z CrMo1Si EN ISO 21952-B : G 55 M13 1CM SFA/AWS A5.28 : ER80S-B2
Approvals	CE : EN 13479 UKCA : EN 13479

Approvals are based on factory location. Please contact ESAB for more information.

Alloy Type	Low-alloyed, 1,3Cr-0,5Mo
Shielding Gas	M13, M21 (EN ISO 14175)

Typical Tensile Properties			
Condition	Yield Strength	Tensile Strength	Elongation
ISO A Ar, 15-25%CO2 (M21)			
PWHT 1 hour(s) 685 °C	460 MPa	580 MPa	26 %
AWS Ar / 1-3% O2 (M13)			
PWHT 1 hour(s) 620 °C	540 MPa	640 MPa	26 %
ISO B Ar, 1-3%O2 (M13)			
PWHT 1 hour(s) 620 °C	530 MPa	610 MPa	23 %

Typical Charpy V-Notch Properties		
Condition	Testing Temperature	Impact Value
ISO A Ar, 15-25%CO2 (M21)		
PWHT 1 hour(s) 685 °C	20 °C	140 J
AWS Ar / 1-3% O2 (M13)		
PWHT 1 hour(s) 620 °C	20 °C	160 J
PWHT 1 hour(s) 620 °C	-20 °C	100 J
ISO B Ar, 1-3%O2 (M13)		
PWHT 1 hour(s) 620 °C	20 °C	160 J

Typical Weld Metal Analysis %							
C	Mn	Si	S	P	Cr	Mo	Cu
0.1	0.4	0.5	0.015	0.010	1.3	0.5	0.10

Typical Wire Composition %					
C	Mn	Si	Ni	Cr	Mo
0.1	0.4	0.5	0.1	1.3	0.5

OK AristoRod 13.16

Deposition Data

Diameter	Current	Voltage	Wire Feed Speed	Deposition Rate
1.2 mm	120-350 A	20-33 V	2.7-12.4 m/min	1.5-6.6 kg/h

OK AristoRod 13.22

The non copper coated OK AristoRod 13.22 is a low-alloyed, chromium-molybdenum (2.6% Cr, 1.1 % Mo), solid wire for GMAW of creep resistant steels of similar composition. For service temperatures up to 600 C. Similar to AWS A5.28 ER80S-B2. The AristoRod wires are suitable for operating at high currents with maintained disturbance free wire feeding giving a stable arc with a low amount of spatter. OK AristoRod 13.22 can even be delivered in the unique Esab Octagonal Marathon Pac is excellent in mechanised welding applications.

Specifications

Classifications	EN ISO 21952-A : G CrMo2Si EN ISO 21952-B : G 62 M 2C1M3 SFA/AWS A5.28 : ER90S-G
Alloy Type	Low alloyed (Cr 2.5% and Mo 1.0%)
Shielding Gas	M21 (EN ISO 14175)

Typical Tensile Properties

Condition	Yield Strength	Tensile Strength	Elongation
EN 80Ar/20CO2 (M21)			
Stress relieved+ 0.5 hour(s) 750 °C	410 MPa	520 MPa	24 %
Stress relieved++ 1 hour(s) 700 °C	550 MPa	660 MPa	21 %
AWS 80Ar/20CO2 (M21)			
As Welded	750 MPa	890 MPa	19 %
As Welded+	680 MPa	880 MPa	19 %

Typical Charpy V-Notch Properties

Condition	Testing Temperature	Impact Value
EN 80Ar/20CO2 (M21)		
Stress relieved++ 1 hour(s) 700 °C	20 °C	130 J
Stress relieved++ 1 hour(s) 700 °C	-20 °C	80 J
Stress relieved++ 1 hour(s) 700 °C	-40 °C	45 J
AWS 80Ar/20CO2 (M21)		
As Welded	20 °C	55 J
As Welded	-40 °C	30 J

Typical Weld Metal Analysis %

C	Mn	Si	S	P	Cr	Mo
80Ar/20CO2 (M21)						
0.06	1.0	0.6	0.015	0.010	2.5	1.0

Typical Wire Composition %

C	Mn	Si	Ni	Cr	Mo
0.07	1.0	0.65	0.1	2.45	1.0

Deposition Data

Diameter	Current	Voltage	Wire Feed Speed	Deposition Rate
1.0 mm	80-280 A	18-28 V	2.7-14.7 m/min	1.0-5.4 kg/h
1.2 mm	120-350 A	20-33 V	2.7-12.4 m/min	1.5-6.6 kg/h

OK AristoRod 13.26

The non copper coated OK AristoRod 13.26 is a low-alloyed, nickel-copper (0,8% Ni, 0,45% Cu), solid wire for GMAW of weathering steels, such as COR-TEN, Patinax, Dillicor etc. According to NACE it would be acceptable to use these welding consumables, since the nickel content is below the maximum acceptable level, 1 % for sour gas applications. One other requirement from NACE is the maximum hardness of the deposited weld metal, which must not exceed 22 HRC. The weld metal composition and mechanical properties also make this product suitable for welding high strength steels with a minimum yield strength less than 470 MPa. The AristoRod wires are suitable for operating at high currents with maintained disturbance free wire feeding giving a stable arc with a low amount of spatter. OK AristoRod 13.26 delivered in the unique Esab Octagonal Marathon Pac is excellent in mechanised welding applications.

Specifications	
Classifications	EN ISO 14341-A : G 42 0 C1 Z 3Ni1Cu EN ISO 14341-A : G 46 4 M21 Z 3Ni1Cu EN ISO 14341-A : G Z 3Ni1Cu SFA/AWS A5.28 : ER80S-G
Approvals	CE : EN 13479 DB : 42.039.32 DNV-GL : II YMS (C1) DNV-GL : III YMS (M21) UKCA : EN 13479 VdTUV : 19755

Approvals are based on factory location. Please contact ESAB for more information.

Alloy Type	Low alloyed (0.8 % Ni, 0.4 % Cu)
Shielding Gas	M21, C1 (EN ISO 14175)

Typical Tensile Properties			
Condition	Yield Strength	Tensile Strength	Elongation
EN 80Ar/20CO2 (M21)			
As Welded	510 MPa	620 MPa	23 %
EN CO2 (C1)			
As Welded	470 MPa	580 MPa	25 %
AWS 80Ar/20CO2 (M21)			
As Welded	540 MPa	625 MPa	26 %
AWS 98Ar/2O2 (M13)			
As Welded	580 MPa	650 MPa	22 %

Typical Charpy V-Notch Properties		
Condition	Testing Temperature	Impact Value
EN 80Ar/20CO2 (M21)		
As Welded	-40 °C	60 J
EN CO2 (C1)		
As Welded	0 °C	65 J
AWS 80Ar/20CO2 (M21)		
As Welded	20 °C	140 J
As Welded	0 °C	140 J
As Welded	-20 °C	110 J
As Welded	-40 °C	80 J
As Welded	-60 °C	50 J
AWS 98Ar/2O2 (M13)		
As Welded	20 °C	140 J
As Welded	-20 °C	100 J
As Welded	-40 °C	70 J
As Welded	-60 °C	30 J

OK AristoRod 13.26

Typical Weld Metal Analysis %

C	Mn	Si	S	P	Ni	Cu
CO₂ (C1)						
0.1	1.3	0.7	0.015	0.010	0.8	0.3
80Ar/20CO₂ (M21)						
0.1	1.4	0.8	0.015	0.010	0.8	0.3

Typical Wire Composition %

C	Mn	Si	Ni	Cr	Mo	Cu
0.095	1.32	0.80	0.84	0.12	0.02	0.30

Deposition Data

Diameter	Current	Voltage	Wire Feed Speed	Deposition Rate
0.8 mm	40-170 A	16-22 V	2.0-10.8 m/min	0.4-2.6 kg/h
1.0 mm	80-280 A	18-28 V	2.7-14.7 m/min	1.0-5.4 kg/h
1.2 mm	120-350 A	20-33 V	2.7-12.4 m/min	1.5-6.6 kg/h
1.6 mm	225-480 A	26-38 V	3.1-8.1 m/min	3.3-0.0 kg/h

OK AristoRod 55

The non copper coated OK AristoRod 55 is a low-alloyed, chromium-nickel-molybdenum (0,5% Cr, 0,5% Ni, 0,2% Mo), solid wire for GMAW of high strength steels. But, also suitable when welding steels where good impact toughness is required at lower temperatures. The AristoRod wires are suitable for operating at high currents with maintained disturbance free wire feeding giving a stable arc with a low amount of spatter. OK AristoRod 55 delivered in the unique ESAB Octagonal Marathon Pac is excellent in mechanised welding applications.

Specifications	
Classifications	EN ISO 16834-A : G 55 4 M20 Mn3NiCrMo EN ISO 16834-A : G 55 4 M21 Mn3NiCrMo EN ISO 16834-A : G Mn3NiCrMo SFA/AWS A5.28 : ER100S-G
Approvals	CE : EN 13479 UKCA : EN 13479

Approvals are based on factory location. Please contact ESAB for more information.

Alloy Type	Low alloyed (0,5 % Cr, 0,5 % Ni, 0,2 % Mo)
Shielding Gas	M20, M21 (EN ISO 14175)

Typical Tensile Properties			
Condition	Yield Strength	Tensile Strength	Elongation
EN 80Ar/20CO2 (M21)			
As Welded	650 MPa	750 MPa	20 %
Stress Relieved 1 hour(s) 570 °C	660 MPa	750 MPa	24 %
Stress relieved+ 1 hour(s) 620 °C	660 MPa	750 MPa	24 %
EN 92Ar/8CO2 (M20)			
As Welded	680 MPa	760 MPa	18 %

Typical Charpy V-Notch Properties		
Condition	Testing Temperature	Impact Value
EN 80Ar/20CO2 (M21)		
As Welded	0 °C	80 J
Stress relieved+ 1 hour(s) 620 °C	0 °C	95 J
As Welded	-20 °C	75 J
Stress Relieved 1 hour(s) 570 °C	-20 °C	60 J
Stress relieved+ 1 hour(s) 620 °C	-20 °C	70 J
As Welded	-30 °C	65 J
Stress relieved+ 1 hour(s) 620 °C	-30 °C	55 J
As Welded	-40 °C	60 J
Stress Relieved 1 hour(s) 570 °C	-40 °C	50 J
As Welded	-50 °C	50 J
Stress relieved+ 1 hour(s) 620 °C	-50 °C	40 J
As Welded	-60 °C	50 J
Stress Relieved 1 hour(s) 570 °C	-60 °C	35 J
EN 92Ar/8CO2 (M20)		

OK AristoRod 55

Typical Charpy V-Notch Properties

Condition	Testing Temperature	Impact Value
As Welded	-30 °C	80 J
As Welded	-40 °C	60 J

Typical Weld Metal Analysis %

C	Mn	Si	S	P	Ni	Cr	Mo	Cu
Ar/20CO ₂								
0.11	1.1	0.5	0.015	0.015	0.5	0.5	0.2	0.07

Typical Wire Composition %

C	Mn	Si	Ni	Cr	Mo
0.12	1.38	0.71	0.53	0.58	0.20

Deposition Data

Diameter	Current	Voltage	Wire Feed Speed	Deposition Rate
0.8 mm	40-170 A	16-22 V	2.0-10.8 m/min	0.4-2.6 kg/h
1.0 mm	80-280 A	18-28 V	2.7-14.7 m/min	1.0-5.4 kg/h
1.2 mm	120-350 A	20-33 V	2.7-12.4 m/min	1.5-6.6 kg/h
1.6 mm	225-480 A	26-38 V	3.5-12.0 m/min	3.3-11.6 kg/h

OK AristoRod 69

The non copper coated OK AristoRod 69 is a low-alloyed, chromium-nickel-molybdenum (0,3% Cr, 1,4% Ni, 0,25% Mo), solid wire for GMAW of high tensile strength steels requiring tough weld metal for critical applications. Also suitable when high impact strength at lower temperatures is required. The AristoRod wires are suitable for operating at high currents with maintained disturbance free wire feeding giving a stable arc with a low amount of spatter. OK AristoRod 69 delivered in the unique Esab Octagonal Marathon Pac is excellent in mechanised welding applications.

Specifications	
Classifications	EN ISO 16834-A : G 69 4 M20 Mn3Ni1CrMo EN ISO 16834-A : G 69 4 M21 Mn3Ni1CrMo EN ISO 16834-A : G Mn3Ni1CrMo SFA/AWS A5.28 : ER110S-G
Approvals	ABS : ER 110S-G (M21) CE : EN 13479 DB : 42.039.33 DNV : G 69 4 M Mn3Ni1CrMo UKCA : EN 13479 VdTUV : 11837

Approvals are based on factory location. Please contact ESAB for more information.

Alloy Type	Low alloyed (1.4 % Ni, 0.3 % Cr, 0.3 % Mo)
Shielding Gas	M20, M21 (EN ISO 14175)

Typical Tensile Properties			
Condition	Yield Strength	Tensile Strength	Elongation
EN 80Ar/20CO₂ (M21)			
As Welded	730 MPa	800 MPa	19 %
Stress Relieved 15 hour(s) 620 °C	690 MPa	750 MPa	20 %
AWS 80Ar/20CO₂ (M21)			
As Welded	715 MPa	805 MPa	17 %
EN 92Ar/8CO₂ (M20)			
As Welded	725 MPa	780 MPa	19 %

Typical Charpy V-Notch Properties		
Condition	Testing Temperature	Impact Value
EN 80Ar/20CO₂ (M21)		
As Welded	20 °C	100 J
Stress Relieved 15 hour(s) 620 °C	20 °C	130 J
Stress Relieved 15 hour(s) 620 °C	-20 °C	60 J
Stress Relieved 15 hour(s) 620 °C	-30 °C	60 J
As Welded	-40 °C	73 J
AWS 80Ar/20CO₂ (M21)		
As Welded	-30 °C	80 J
As Welded	-40 °C	60 J
EN 92Ar/8CO₂ (M20)		
As Welded	-40 °C	65 J

Typical Weld Metal Analysis %									
C	Mn	Si	S	P	Ni	Cr	Mo	V	Cu
80Ar/20CO ₂ (M21)									

OK AristoRod 69

Typical Weld Metal Analysis %

C	Mn	Si	S	P	Ni	Cr	Mo	V	Cu
0.06	1.6	0.6	0.01	0.01	1.4	0.3	0.25	0.07	0.07

Typical Wire Composition %

C	Mn	Si	Ni	Cr	Mo
0.089	1.54	0.53	1.23	0.26	0.24

Deposition Data

Diameter	Current	Voltage	Wire Feed Speed	Deposition Rate
0.8 mm	80-280 A	18-28 V	2.7-14.7 m/min	1.0-5.4 kg/h
0.9 mm	80-280 A	18-28 V	2.7-14.7 m/min	1.0-5.4 kg/h
1.0 mm	80-280 A	18-28 V	2.7-14.7 m/min	1.0-5.4 kg/h
1.2 mm	120-350 A	20-33 V	2.7-12.4 m/min	1.5-6.6 kg/h
1.6 mm	225-480 A	26-38 V	3.1-8.1 m/min	3.3 kg/h

OK AristoRod 79

The non copper coated OK AristoRod 79 is a low-alloyed, chromium-nickel-molybdenum (0,3% Cr, 1,9% Ni, 0,5% Mo), solid wire for GMAW of high tensile strength steels, heat treated steels and fine grained constructional steels, such as XABO90 with a minimum yield strength less than 850 MPa. The AristoRod wires are suitable for operating at high currents with maintained disturbance free wire feeding giving a stable arc with a low amount of spatter. OK AristoRod 79 delivered in the unique ESAB Octagonal Marathon Pac is excellent in mechanised welding applications.

Specifications	
Classifications	EN ISO 16834-A : G 79 4 M20 Mn4Ni2CrMo EN ISO 16834-A : G 79 4 M21 Mn4Ni2CrMo EN ISO 16834-A : G Mn4Ni2CrMo SFA/AWS A5.28 : ER120S-G
Approvals	CE : EN 13479 UKCA : EN 13479

Approvals are based on factory location. Please contact ESAB for more information.

Alloy Type	0,3% Cr, 1,9% Ni, 0,5% Mo
Shielding Gas	M20, M21 (EN ISO 14175)

Typical Tensile Properties			
Condition	Yield Strength	Tensile Strength	Elongation
EN 80Ar/20CO₂ (M21)			
As Welded	810 MPa	900 MPa	18 %
EN 92Ar/8CO₂ (M20)			
As Welded	825 MPa	900 MPa	17 %

Typical Charpy V-Notch Properties		
Condition	Testing Temperature	Impact Value
EN 80Ar/20CO₂ (M21)		
As Welded	0 °C	70 J
As Welded	-20 °C	60 J
As Welded	-40 °C	55 J
EN 92Ar/8CO₂ (M20)		
As Welded	-40 °C	75 J
As Welded	-50 °C	65 J

Typical Weld Metal Analysis %									
C	Mn	Si	S	P	Ni	Cr	Mo	Cu	Ti
80Ar/20CO₂ (M21)									
0.1	1.7	0.7	0.01	0.01	1.9	0.3	0.5	0.07	0.03

Typical Wire Composition %						
C	Mn	Si	Ni	Cr	Mo	
0.09	1.82	0.89	2.03	0.25	0.64	

Deposition Data				
Diameter	Current	Voltage	Wire Feed Speed	Deposition Rate
1.0 mm	80-280 A	18-28 V	2.7-14.7 m/min	1.0-5.4 kg/h
1.2 mm	120-350 A	20-33 V	2.7-12.4 m/min	1.5-6.6 kg/h

OK AristoRod 89

The non copper coated OK AristoRod 89 is a low-alloyed, chromium-nickel-molybdenum (0,4% Cr, 2,2% Ni, 0,55% Mo), solid wire for GMAW of ultra high tensile strength steels requiring tough weld metal for critical applications. Also suitable when high impact strength at lower temperatures is required. The AristoRod wires are suitable for operating at high currents with maintained disturbance free wire feeding giving a stable arc with a low amount of spatter, due to its unique Advanced Surface Characteristics (ASC) technology. OK AristoRod 89 is delivered on spools or in the unique ESAB Octagonal Marathon Pac, which is excellent in mechanised welding applications. Typical materials according to ISO 15608:2000 and some brand names from steel suppliers are S890QL, Weldox 900, 1100, 1300, Domex 960, XABO 890, 960, 1100, NAXTRA 70, OX-700, 800, 1002, Optim 900QC, 960QC, 1100QC, T1 - HY80.

Specifications	
Classifications	EN ISO 16834-A : G Mn4Ni2CrMo SFA/AWS A5.28 : ER120S-G EN ISO 16834-A : G 89 4 M20 Mn4Ni2CrMo EN ISO 16834-A : G 89 4 M21 Mn4Ni2CrMo
Approvals	CE : EN 13479 DB : 42.039.37 DNV : G 89 4 M Mn4Ni2CrMo UKCA : EN 13479 VdTÜV : 11881

Approvals are based on factory location. Please contact ESAB for more information.

Alloy Type	0,4% Cr, 2,2%Ni, 0,55% Mo
Shielding Gas	M20, M21 (EN ISO 14175)

Typical Tensile Properties			
Condition	Yield Strength	Tensile Strength	Elongation
EN 80Ar/20CO2 (M21)			
As Welded	920 MPa	960 MPa	18 %
EN 92Ar/8CO2 (M20)			
As Welded	905 MPa	960 MPa	19 %

Typical Charpy V-Notch Properties		
Condition	Testing Temperature	Impact Value
EN 80Ar/20CO2 (M21)		
As Welded	-40 °C	55 J
EN 92Ar/8CO2 (M20)		
As Welded	-40 °C	75 J
As Welded	-50 °C	65 J

Typical Wire Composition %					
C	Mn	Si	Ni	Cr	Mo
0.081	1.75	0.8	2.22	0.41	0.533

Deposition Data				
Diameter	Current	Voltage	Wire Feed Speed	Deposition Rate
0.8 mm	40-170 A	16-22 V	2.0-10.8 m/min	0.4-2.6 kg/h
1.0 mm	80-280 A	18-28 V	2.7-14.7 m/min	1.0-5.4 kg/h
1.2 mm	120-350 A	20-33 V	2.7-12.4 m/min	1.5-6.6 kg/h

OK Autrod 13.17

A copper coated, low-alloyed, chromium-molybdenum (2.5% Cr, 1.1% Mo), solid wire for GMAW of creep resistant steels like SA-387 Grade 22, A335 Grade P22 or similar materials. High purity wire with a guaranteed Bruscato factor X<15.

Specifications

Classifications	EN ISO 21952-B : G 62A 2C1M SFA/AWS A5.28 : ER90S-B3
------------------------	---

Shielding Gas	M13, M21 (EN ISO 14175)
----------------------	-------------------------

Typical Tensile Properties

Condition	Yield Strength	Tensile Strength	Elongation
M21 AWS			
Stress Relieved 1 hour(s) 690 °C	590 MPa	720 MPa	22 %

Typical Charpy V-Notch Properties

Condition	Testing Temperature	Impact Value
M21 AWS		
Stress Relieved 1 hour(s) 690 °C	-40 °C	47 J

Typical Weld Metal Analysis %

C	Mn	Si	S	P	Cr	Mo	Cu
M21							
0.1	0.5	0.5	0.005	0.008	2	1.0	0.15

Typical Wire Composition %

C	Mn	Si	Ni	Cr	Mo
0.1	0.5	0.5	0.05	2.4	1.0

Deposition Data

Diameter	Current	Voltage	Wire Feed Speed	Deposition Rate
1.2 mm	120-350 A	20-33 V	2.7-12.4 m/min	1.5-6.6 kg/h

OK Autrod 13.23

A copper coated, Ni-alloyed (0,9% Ni), solid wire for GMAW of low-temperature fine-grained steels. The wire provides good impact toughness down to -50 °C and is especially suitable for use in the offshore industry.

Specifications

Classifications	EN ISO 14341-A : G50 4 M21 Z3Ni SFA/AWS A5.28 : ER80S-Ni1 EN ISO 14341-B : G55A 5 M21 SN2 EN ISO 14341-B : G55P 5U M21 SN2
Approvals	BV : SA4Y40M

Approvals are based on factory location. Please contact ESAB for more information.

Alloy Type	Low alloyed (1 % Ni)
Shielding Gas	M21 (EN ISO 14175)

Typical Tensile Properties

Condition	Yield Strength	Tensile Strength	Elongation
EN ISO 80Ar/20CO2			
As Welded	550 MPa	640 MPa	25 %
Stress Relieved 1 hour(s) 620 °C	500 MPa	600 MPa	27 %
AWS 80Ar/20CO2			
As Welded	480 MPa	560 MPa	30 %

Typical Charpy V-Notch Properties

Condition	Testing Temperature	Impact Value
EN ISO 80Ar/20CO2		
As Welded	-40 °C	60 J
Stress Relieved 1 hour(s) 620 °C	-50 °C	80 J
AWS 80Ar/20CO2		
As Welded	20 °C	150 J
As Welded	0 °C	130 J
As Welded	-46 °C	70 J
As Welded	-60 °C	20 J

Typical Weld Metal Analysis %

C	Mn	Si	S	P	Ni	Cr	Mo	V	Cu
Ar-80%, CO2-20% (M21)									
0.09	1.00	0.60	0.010	0.010	0.90	0.10	0.20	0.01	0.10

Typical Wire Composition %

C	Mn	Si	S	P	Ni	Cr	Mo	V	Cu
0.07	1.11	0.57	0.010	0.010	0.9	0.07	0.29	0.01	0.15

Deposition Data

Diameter	Current	Voltage	Wire Feed Speed	Deposition Rate
1.0 mm	80-280 A	18-28 V	2.7-14.7 m/min	1.0-5.4 kg/h
1.2 mm	120-350 A	20-33 V	2.7-12.4 m/min	1.5-6.6 kg/h

OK Autrod 13.25

A copper coated, low-alloyed, nickel-molybdenum-titanium (1,0 % Ni, 0,3% Mo, 0,1% Ti), solid wire for GMAW of low alloyed high tensile strength steels and fine grained steels for use in constructions such as bridges, off-shore and hoists with a minimum yield strength less than 610 Mpa. The alloy has good impact properties down to -60C. When used in mechanical pipe welding in narrow groove, yield strengths in excess of 700 MPa may be obtained, allowing overmatching of X80 pipeline steel.

Specifications	
Classifications	EN ISO 16834-A : G 62 6 M21 Mn3Ni1Mo EN ISO 16834-A : G Mn3Ni1Mo SFA/AWS A5.28 : ER100S-G

Alloy Type	Low alloyed (1 % Ni, 0.3 % Mo, 0.1 % Ti)
------------	--

Typical Tensile Properties			
Condition	Yield Strength	Tensile Strength	Elongation
AWS 80Ar/20CO2			
As Welded	640 MPa	730 MPa	20 %
EN 80Ar/20CO2			
As Welded	680 MPa	740 MPa	20 %

Typical Charpy V-Notch Properties		
Condition	Testing Temperature	Impact Value
AWS 80Ar/20CO2		
As Welded	20 °C	140 J
As Welded	-40 °C	90 J
As Welded	-60 °C	70 J
EN 80Ar/20CO2		
As Welded	20 °C	150 J
As Welded	-40 °C	110 J
As Welded	-60 °C	70 J

Typical Weld Metal Analysis %							
C	Mn	Si	S	P	Ni	Mo	Ti
80Ar/20CO2 (M21)							
0.07	1.5	0.5	0.01	0.01	0.95	0.3	0.05

Typical Wire Composition %					
C	Mn	Si	Ni	Mo	Ti
0.08	1.70	0.60	0.95	0.38	0.08

Deposition Data				
Diameter	Current	Voltage	Wire Feed Speed	Deposition Rate
1.0 mm	80-280 A	18-28 V	2.7-14.7 m/min	1.0-5.4 kg/h
1.2 mm	120-350 A	20-33 V	2.7-12.4 m/min	1.5-6.6 kg/h

OK Autrod 13.28

A copper coated, Ni-alloyed (2,4% Ni), solid wire for GMAW of low-alloyed and low temperature steels in applications such as vessels, pipes and in the offshore industry with a minimum yield strength less than 470 Mpa. The wire provides a good impact toughness down to -60°C.

Specifications

Classifications	EN ISO 14341-A : G 46 6 M21 2Ni2 EN ISO 14341-A : G 2Ni2 SFA/AWS A5.28 : ER80S-Ni2
Approvals	CE : EN 13479 DNV-GL : V YMS (M21) UKCA : EN 13479 VdTÜV : 06852

Approvals are based on factory location. Please contact ESAB for more information.

Alloy Type	Low alloyed (2.5 % Ni)
Shielding Gas	M21 (EN ISO 14175)

Typical Tensile Properties

Condition	Yield Strength	Tensile Strength	Elongation
EN Ar/20CO2 (M21)			
As Welded	540 MPa	630 MPa	28 %
AWS Ar/1-5O2 (M13)			
Stress Relieved 1 hour(s) 620 °C	540 MPa	630 MPa	29 %

Typical Charpy V-Notch Properties

Condition	Testing Temperature	Impact Value
EN Ar/20CO2 (M21)		
As Welded	0 °C	130 J
As Welded	-40 °C	100 J
As Welded	-60 °C	60 J
AWS Ar/1-5O2 (M13)		
Stress Relieved 1 hour(s) 620 °C	0 °C	162 J
Stress Relieved 1 hour(s) 620 °C	-29 °C	168 J
Stress Relieved 1 hour(s) 620 °C	-62 °C	131 J

Typical Weld Metal Analysis %

C	Mn	Si	S	P	Ni	Cr	Mo	V	Al
0.1	1	0.4	0.01	0.01	2.4	0.05	0.1	0.001	0.01

Typical Weld Metal Analysis %

Cu	Ti+Zr
0.15	0.05

Typical Wire Composition %

C	Mn	Si	Ni
0.08	1.04	0.53	2.36

OK Autrod 13.28

Deposition Data				
Diameter	Current	Voltage	Wire Feed Speed	Deposition Rate
1.0 mm	80-280 A	18-28 V	2.7-14.7 m/min	1.0-5.4 kg/h
1.2 mm	120-350 A	20-33 V	2.7-12.4 m/min	1.5-6.6 kg/h

OK Autrod 13.29

A copper coated, low-alloyed, chromium-nickel-molybdenum (0,3% Cr, 1,4% Ni, 0,25% Mo), solid wire for GMAW of high tensile strength steels requiring tougher weld metal for critical applications. Also suitable when fairly high impact strength at lower temperatures is required. OK Autrod 13.29 delivered in the unique Esab Octagonal Marathon Pac is excellent in mechanised welding applications.

Specifications

Classifications	EN ISO 16834-A : G 69 4 M20 Mn3Ni1CrMo EN ISO 16834-A : G 69 4 M21 Mn3Ni1CrMo EN ISO 16834-A : G Mn3Ni1CrMo SFA/AWS A5.28 : ER100S-G
Approvals	CE : EN 13479 DB : 42.039.18 UKCA : EN 13479 VdTUV : 04436

Approvals are based on factory location. Please contact ESAB for more information.

Alloy Type	Low alloyed (1.4 % Ni, 0.3 % Cr, 0.3 % Mo)
Shielding Gas	M20, M21 (EN ISO 14175)

Typical Tensile Properties

Condition	Yield Strength	Tensile Strength	Elongation
AWS M21			
As Welded	715 MPa	805 MPa	17 %
EN M21			
As Welded	730 MPa	800 MPa	19 %
Stress Relieved 15 hour(s) 620 °C	690 MPa	750 MPa	20 %
EN M20			
As Welded	725 MPa	780 MPa	19 %

Typical Charpy V-Notch Properties

Condition	Testing Temperature	Impact Value
AWS M21		
As Welded	-30 °C	80 J
As Welded	-40 °C	60 J
EN M21		
As Welded	20 °C	100 J
Stress Relieved 15 hour(s) 620 °C	20 °C	130 J
Stress Relieved 15 hour(s) 620 °C	-20 °C	60 J
Stress Relieved 15 hour(s) 620 °C	-30 °C	60 J
As Welded	-40 °C	60 J
EN M20		
As Welded	-40 °C	85 J

Typical Weld Metal Analysis %

C	Mn	Si	S	P	Ni	Cr	Mo	V	Cu
M21									
0.06	1.6	0.6	0.01	0.01	1.4	0.3	0.25	0.07	0.3

OK Autrod 13.29

Typical Wire Composition %

C	Mn	Si	Ni	Cr	Mo
0.089	1.54	0.53	1.23	0.26	0.24

Deposition Data

Diameter	Current	Voltage	Wire Feed Speed	Deposition Rate
0.8 mm	40-170 A	16-22 V	2.0-10.8 m/min	0.4-2.6 kg/h
1.0 mm	80-280 A	18-28 V	2.7-14.7 m/min	1.0-5.4 kg/h
1.2 mm	120-350 A	20-33 V	2.7-12.4 m/min	1.5-6.6 kg/h
1.6 mm	225-480 A	26-38 V	3.1-8.1 m/min	3.3 kg/h

OK Autrod 13.37

A copper coated, low-alloyed, chromium-molybdenum (9% Cr, 1% Mo), solid wire for GMAW of high temperature steels and steels for hot hydrogen service, especially in oil refineries. The electrode is a plain ER505 type.

Specifications

Classifications	EN ISO 21952-A : G CrMo9 EN ISO 21952-B : G 55A 9C1M SFA/AWS A5.28 : ER80S-B8
------------------------	---

Alloy Type	Alloyed steel (9 % Cr, 1 % Mo)
Shielding Gas	M12, M13, M21 (EN ISO 14175)

Typical Tensile Properties

Condition	Yield Strength	Tensile Strength	Elongation
EN 80Ar/20CO2 (M21)			
Stress Relieved 2 hour(s) 760 °C	536 MPa	620 MPa	23 %
AWS Ar/1-5%O2 (M13)			
Stress Relieved 2 hour(s) 745 °C	523 MPa	680 MPa	22 %

Typical Charpy V-Notch Properties

Condition	Testing Temperature	Impact Value
EN 80Ar/20CO2 (M21)		
Stress Relieved 2 hour(s) 760 °C	20 °C	91 J
Stress Relieved 2 hour(s) 760 °C	-20 °C	50 J
AWS Ar/1-5%O2 (M13)		
Stress Relieved 2 hour(s) 745 °C	20 °C	115 J
Stress Relieved 2 hour(s) 745 °C	-20 °C	50 J

Typical Weld Metal Analysis %

C	Mn	Si	S	P	Ni	Cr	Mo	Cu
0.1	0.5	0.4	0.005	0.01	0.1	8.6	0.9	0.15

Typical Wire Composition %

C	Mn	Si	Ni	Cr	Mo
0.06	0.52	0.45	0.23	8.66	1.00

Deposition Data

Diameter	Current	Voltage	Wire Feed Speed	Deposition Rate
0.9 mm	70-250 A	18-26 V	3.0-12.0 m/min	0.9-3.5 kg/h
1.2 mm	120-350 A	20-33 V	2.7-12.4 m/min	1.5-6.6 kg/h

OK Tigrod 13.08

A copper coated, low alloyed, manganese-molybdenum (1,5% Mn, 0,4% Mo) rod for GTAW of creep resistant steels of the same type, such as pipes in pressure vessels and boilers with a working temperature of up to about 500°C. The rod can also be used for welding low-alloyed high tensile strength steels.

Specifications

Classifications	EN ISO 636-A : W 50 3 Z 2Mo EN ISO 636-B : W55A 3 4M31 EN ISO 636-A : Z 2Mo EN ISO 636-B : 4M31 SFA/AWS A5.28 : ER80S-D2
------------------------	--

Alloy Type	Low alloyed steel (0.5 % Mo)
Shielding Gas	I1 (EN ISO 14175)

Typical Tensile Properties

Condition	Yield Strength	Tensile Strength	Elongation
Ar (I1) AWS			
As Welded	520 MPa	615 MPa	28 %
Ar (I1) EN			
As Welded	620 MPa	690 MPa	24 %

Typical Charpy V-Notch Properties

Condition	Testing Temperature	Impact Value
Ar (I1) AWS		
As Welded	-30 °C	80 J
Ar (I1) EN		
As Welded	-30 °C	110 J

Typical Wire Composition %

C	Mn	Si	Ni	Mo
0.07	1.8	0.7	0.05	0.4

OK Tigrod 13.09

A copper coated, low alloyed, molybdenum (0.5% Mo) rod for GTAW of creep resistant steels of the same type, such as pipes in pressure vessels and boilers with a working temperature of up to about 500°C.

Specifications

Classifications	EN ISO 636-A : W 46 2 2Mo EN ISO 636-A : W 2Mo EN ISO 21952-A : W MoSi EN ISO 21952-B : W 52 1M3 SFA/AWS A5.28 : ER70S-A1 (ER80S-G)
Approvals	CE : EN 13479 DB : 42.039.08 DNV-GL : III YMS (I1) UKCA : EN 13479 VdTÜV : 04950

Approvals are based on factory location. Please contact ESAB for more information.

Alloy Type	Low alloyed steel (0.5 % Mo)
Shielding Gas	I1 (EN ISO 14175)

Typical Tensile Properties

Condition	Yield Strength	Tensile Strength	Elongation
EN Ar (I1)			
As Welded	490 MPa	600 MPa	30 %
PWHT 1 hour(s) 620 °C	450 MPa	550 MPa	31 %
AWS Ar (I1)			
As Welded	520 MPa	620 MPa	27 %
PWHT 1 hour(s) 620 °C	510 MPa	610 MPa	28 %

Typical Charpy V-Notch Properties

Condition	Testing Temperature	Impact Value
EN Ar (I1)		
As Welded	20 °C	180 J
PWHT 1 hour(s) 620 °C	20 °C	190 J
As Welded	-20 °C	160 J
PWHT 1 hour(s) 620 °C	-20 °C	170 J
As Welded	-40 °C	90 J
As Welded	-60 °C	25 J
AWS Ar (I1)		
PWHT 1 hour(s) 620 °C	-20 °C	220 J
As Welded	-29 °C	150 J
As Welded	-46 °C	130 J

Typical Weld Metal Analysis %

C	Mn	Si	S	P	Mo	Cu
0.1	1.1	0.7	0.015	0.015	0.5	0.2

OK Tigrod 13.09

Typical Wire Composition %

C	Mn	Si	Ni	Cr	Mo
0.094	1.09	0.61	0.05	0.05	0.45

OK Tigrod 13.12

A copper coated, low alloyed, chromium-molybdenum (1% Cr, 0,5% Mo) rod for GTAW of creep resistant steels of the same type, such as pipes in pressure vessels and boilers. The rod can also be used for welding low-alloyed high strength steels with a minimum tensile strength of 550 Mpa.

Specifications

Classifications	EN ISO 21952-A : W CrMo1Si EN ISO 21952-B : W 55 11 1CM3 SFA/AWS A5.28 : ER80S-G
Approvals	CE : EN 13479 UKCA : EN 13479 VdTÜV : 04952

Approvals are based on factory location. Please contact ESAB for more information.

Alloy Type	Low alloyed steel (1 % Cr - 0.5 % Mo)
Shielding Gas	I1 (EN ISO 14175)

Typical Tensile Properties

Condition	Yield Strength	Tensile Strength	Elongation
Ar (I1) EN ISO			
Stress Relieved 1 hour(s) 700 °C	560 MPa	650 MPa	25 %
Ar (I1) AWS			
As Welded	560 MPa	720 MPa	24 %

Typical Charpy V-Notch Properties

Condition	Testing Temperature	Impact Value
Ar (I1) EN ISO		
Stress Relieved 1 hour(s) 700 °C	20 °C	250 J
Stress Relieved 1 hour(s) 700 °C	-40 °C	120 J
Ar (I1) AWS		
As Welded	20 °C	120 J
As Welded	-20 °C	50 J
As Welded	-30 °C	40 J
As Welded	-40 °C	20 J
As Welded	-60 °C	20 J

Typical Weld Metal Analysis %

C	Mn	Si	S	P	Cr	Mo
0.10	1.00	0.70	0.015	0.015	1.10	0.50

Typical Wire Composition %

C	Mn	Si	S	P	Cr	Mo
0.09	1.00	0.65	0.010	0.015	1.18	0.49

OK Tigrod 13.16

A copper coated, low-alloyed, chromium-molybdenum (1,3% Cr, 0,5% Mo), rod for GTAW of creep resistant steels like SA-387 Grade 11, A 335 Grade P11 or similar materials. OK Tigrod 13.16 is a high purity wire with a guaranteed Bruscato factor X<10.

Specifications	
Classifications	EN ISO 21952-A : Z CrMo1Si EN ISO 21952-B : W 55 1CM SFA/AWS A5.28 : ER80S-B2
Approvals	CE : EN 13479 UKCA : EN 13479

Approvals are based on factory location. Please contact ESAB for more information.

Alloy Type	Low alloyed steel (1,3%Cr, 0.5 % Mo)
Shielding Gas	I1 (EN ISO 14175)

Typical Tensile Properties			
Condition	Yield Strength	Tensile Strength	Elongation
I1 AWS			
PWHT 1 hour(s) 620 °C	640 MPa	730 MPa	24 %

Typical Weld Metal Analysis %							
C	Mn	Si	S	P	Cr	Mo	Cu
I1							
0.08	0.5	0.5	0.01	0.010	1.3	0.5	0.15

Typical Wire Composition %								
C	Mn	Si	S	P	Ni	Cr	Mo	Cu
0.09	0.53	0.56	0.002	0.004	0.022	1.40	0.53	0.06

OK Tigrod 13.17

A copper coated, low-alloyed, chromium-molybdenum (2,5% Cr, 1,1 % Mo), solid wire for GTAW of creep resistant steels like SA-387 Grade 22, A335 Grade P22 or similar materials. High purity wire with a guaranteed Bruscato factor, X-bar <15. Usually welding is followed by a stress relieving heat treatment at 600-700 °C.

Specifications

Classifications	EN ISO 21952-A : Z CrMo2Si EN ISO 21952-B : W 62 2C1M SFA/AWS A5.28 : ER90S-B3
Approvals	CE : EN 13479 UKCA : EN 13479

Approvals are based on factory location. Please contact ESAB for more information.

Alloy Type	Low alloyed steel (2,5%Cr, 1 % Mo)
Shielding Gas	I1 (EN ISO 14175)

Typical Tensile Properties

Condition	Yield Strength	Tensile Strength	Elongation
AWS			
PWHT 1 hour(s) 690 °C	570 MPa	690 MPa	27 %

Typical Charpy V-Notch Properties

Condition	Testing Temperature	Impact Value
AWS		
PWHT 1 hour(s) 690 °C	-40 °C	150 J

Typical Weld Metal Analysis %

C	Mn	Si	S	P	Cr	Mo	Cu
0.08	0.5	0.5	0.005	0.008	2.4	1.0	0.15

Typical Wire Composition %

C	Mn	Si	Ni	Cr	Mo
0.08	0.5	0.5	0.05	2.4	1.0

OK Tigrod 13.22

A copper coated, low alloyed, chromium-molybdenum (2,5% Cr, 1,0% Mo) rod for GTAW of creep resistant steels of the same type, such as pipes in pressure vessels and boilers. The rod can also be used for welding low-alloyed high strength steels with a minimum yield strength less than 400 Mpa. For service temperatures up to 600°C. Similar to AWS A5.28 ER80S-B2.

Specifications	
Classifications	EN ISO 21952-A : W CrMo2Si EN ISO 21952-B : W 62 2C1M3 SFA/AWS A5.28 : ER90S-G
Approvals	VdTÜV : 11884

Approvals are based on factory location. Please contact ESAB for more information.

Alloy Type	Low alloyed steel (2.5 % Cr - 1.0 % Mo)
Shielding Gas	I1 (EN ISO 14175)

Typical Tensile Properties			
Condition	Yield Strength	Tensile Strength	Elongation
EN I1 (Ar)			
Stress Relieved 1 hour(s) 720 °C	530 MPa	640 MPa	24 %
AWS and EN I1 (Ar)			
Stress relieved+ 1 hour(s) 690 °C	550 MPa	655 MPa	24 %

Typical Charpy V-Notch Properties		
Condition	Testing Temperature	Impact Value
EN I1 (Ar)		
Stress Relieved 1 hour(s) 720 °C	20 °C	120 J
AWS and EN I1 (Ar)		
Stress relieved+ 1 hour(s) 690 °C	20 °C	190 J

Typical Weld Metal Analysis %						
C	Mn	Si	S	P	Cr	Mo
Ar						
0.06	1.0	0.6	0.015	0.015	2.5	1.0

Typical Wire Composition %					
C	Mn	Si	Ni	Cr	Mo
0.07	1.02	0.61	0.08	2.45	1.01

OK Tigrod 13.23

A copper coated, Ni and Mo-alloyed (0,9% Ni, 0,3% Mo), rod for GTAW of low-temperature fine-grained steels. The wire provides good impact toughness down to -50 °C and is especially suitable for use in the offshore industry.

Specifications

Classifications	EN ISO 636-A : W 46 5 Z3Ni1 EN ISO 636-A : W Z3Ni1 SFA/AWS A5.28 : ER80S-Ni1
Approvals	CE : EN 13479 DNV : IV Y40M (I1) UKCA : EN 13479

Approvals are based on factory location. Please contact ESAB for more information.

Alloy Type	Low alloyed steel (1% Ni, 0,3% Mo)
Shielding Gas	I1 (EN ISO 14175)

Typical Tensile Properties

Condition	Yield Strength	Tensile Strength	Elongation
Ar (I1) EN ISO			
As Welded	500 MPa	600 MPa	27 %
Ar (I1) AWS			
As Welded	500 MPa	600 MPa	25 %

Typical Charpy V-Notch Properties

Condition	Testing Temperature	Impact Value
Ar (I1) EN ISO		
As Welded	-50 °C	130 J
As Welded	-60 °C	80 J
Ar (I1) AWS		
As Welded	0 °C	230 J
As Welded	-20 °C	200 J
As Welded	-46 °C	140 J
As Welded	-60 °C	90 J

Typical Weld Metal Analysis %

C	Mn	Si	S	P	Ni	Cr	Mo	V	Cu
Ar (I1)									
0.08	1.0	0.7	0.01	0.01	0.9	0.01	0.25	0.01	0.15
-	-	-	-	-	-	0.01	-	-	-

Typical Wire Composition %

C	Mn	Si	Ni	Mo
0.07	1.11	0.57	0.9	0.29

OK Tigrod 13.26

A copper coated, low-alloyed, nickel-copper (0,8% Ni, 0,45% Cu), rod for GTAW of weathering steels, such as COR-TEN, Patinax, Dillicor etc. According to NACE it would be acceptable to use these welding consumables, since the nickel content is below the maximum acceptable level, 1 % for sour gas applications. One other requirement from NACE is the maximum hardness of the deposited weld metal, which must not exceed 22 HRC. The weld metal composition and mechanical properties also make this product suitable for welding high strength steels with a minimum yield strength less than 470 MPa.

Specifications	
Classifications	EN ISO 636-A : W 46 6 Z 3Ni1Cu EN ISO 636-A : W Z 3Ni1Cu SFA/AWS A5.28 : ER80S-G
Approvals	CE : EN 13479 DNV-GL : IV YM (11) UKCA : EN 13479

Approvals are based on factory location. Please contact ESAB for more information.

Alloy Type	Low alloyed steel (0.8 % Ni - 0.4 % Cu)
Shielding Gas	I1 (EN ISO 14175)

Typical Tensile Properties			
Condition	Yield Strength	Tensile Strength	Elongation
EN I1			
As Welded	490 MPa	580 MPa	30 %
AWS I1			
Stress Relieved 2 hour(s) 650 °C	430 MPa	545 MPa	32 %

Typical Charpy V-Notch Properties		
Condition	Testing Temperature	Impact Value
EN I1		
As Welded	20 °C	200 J
As Welded	-20 °C	140 J
As Welded	-40 °C	100 J
As Welded	-60 °C	60 J
AWS I1		
Stress Relieved 2 hour(s) 650 °C	20 °C	230 J
Stress Relieved 2 hour(s) 650 °C	-20 °C	210 J
Stress Relieved 2 hour(s) 650 °C	-40 °C	170 J
Stress Relieved 2 hour(s) 650 °C	-60 °C	160 J

Typical Weld Metal Analysis %						
C	Mn	Si	S	P	Ni	Cu
I1						
0.07	1.3	0.7	0.015	0.015	0.8	0.35

Typical Wire Composition %						
C	Mn	Si	Ni	Cr	Mo	Cu
0.095	1.32	0.80	0.8	0.06	0.006	0.5

OK Tigrod 13.28

A copper coated, Ni-alloyed (2,4% Ni), rod for GTAW of low-alloyed and low temperature steels in applications such as vessels, pipes and in the offshore industry with a minimum yield strength less than 470 Mpa. The wire provides a good impact toughness down to -60 C

Specifications

Classifications	EN ISO 636-A : W 46 6 2Ni2 EN ISO 636-A : W 2Ni2 SFA/AWS A5.28 : ER80S-Ni2
Approvals	VdTÜV : 06243 (RG)

Approvals are based on factory location. Please contact ESAB for more information.

Alloy Type	Low alloyed steel (2.8 % Ni)
Shielding Gas	I1 (EN ISO 14175)

Typical Tensile Properties

Condition	Yield Strength	Tensile Strength	Elongation
I1 AWS			
As Welded	495 MPa	600 MPa	31 %
Stress Relieved 1 hour(s) 620 °C	515 MPa	585 MPa	30 %
I1 EN			
As Welded	540 MPa	630 MPa	30 %

Typical Charpy V-Notch Properties

Condition	Testing Temperature	Impact Value
I1 AWS		
As Welded	-60 °C	180 J
Stress Relieved 1 hour(s) 620 °C	-101 °C	150 J
I1 EN		
As Welded	-60 °C	160 J

Typical Weld Metal Analysis %

C	Mn	Si	S	P	Ni	Cu
0.10	1.1	0.6	0.015	0.015	2.4	0.15

Typical Wire Composition %

C	Mn	Si	Ni	Cr
0.08	1.04	0.53	2.36	0.03

OK Tigrod 13.32

A copper coated, low-alloyed, chromium-molybdenum (5% Cr, 0.5% Mo), rod for GTAW of creep resistant steels of similar composition. Also suitable in welding of high strength steels with a minimum yield strength less than 730 Mpa. AWS have changed the classification for this product, earlier classification was A5.9 ER502.

Specifications

Classifications	EN ISO 21952-A : W CrMo5Si EN ISO 21952-B : W 55 5CM SFA/AWS A5.28 : ER80S-B6
Alloy Type	Low alloyed steel (5 % Cr - 0.5 % Mo)
Shielding Gas	I1 (EN ISO 14175)

Typical Tensile Properties

Condition	Yield Strength	Tensile Strength	Elongation
EN I1			
Stress Relieved 1 hour(s) 730-760 °C	550 MPa	640 MPa	23 %
Stress relieved+ 1 hour(s) 730-760 °C	465 MPa	527 MPa	18 %
Stress relieved++ 1 hour(s) 730-760 °C	430 MPa	477 MPa	19 %
AWS I1			
As Welded	730 MPa	900 MPa	22 %
Stress Relieved 1 hour(s) 745 °C	580 MPa	680 MPa	22 %

Typical Charpy V-Notch Properties

Condition	Testing Temperature	Impact Value
EN I1		
Stress Relieved 1 hour(s) 730-760 °C	20 °C	250 J
AWS I1		
As Welded	20 °C	100 J
Stress Relieved 1 hour(s) 745 °C	20 °C	230 J
As Welded	-20 °C	80 J
Stress Relieved 1 hour(s) 745 °C	-20 °C	200 J
As Welded	-29 °C	50 J
Stress Relieved 1 hour(s) 745 °C	-29 °C	200 J

Typical Wire Composition %

C	Mn	Si	Ni	Cr	Mo
0.07	0.48	0.44	0.06	5.73	0.58

Recommended Welding Parameters

Wire Diameter	Current
2.0 mm	60-200 A
2.4 mm	100-220 A
3.2 mm	130-250 A

OK Tigrod 13.37

A copper coated, low-alloyed, chromium-molybdenum (9% Cr, 1% Mo), rod for GTAW of high temperature steels and steels for hot hydrogen service, especially in oil refineries. The electrode is a plain ER505 type.

Specifications

Classifications	EN ISO 21952-A : W CrMo9 EN ISO 21952-B : W 55 9C1M SFA/AWS A5.28 : ER80S-B8
Alloy Type	Alloyed steel (9 % Cr - 1 % Mo) "ER505"
Shielding Gas	I1 (EN ISO 14175)

Typical Tensile Properties

Condition	Yield Strength	Tensile Strength	Elongation
Enhanced testing temperature.			
Stress Relieved 2 hour(s) 760 °C	430 MPa	500 MPa	17 %
Stress relieved+ 2 hour(s) 760 °C	410 MPa	480 MPa	18 %
Stress relieved++ 2 hour(s) 760 °C	350 MPa	390 MPa	22 %
Ar (I1) EN			
Stress Relieved 2 hour(s) 760 °C	540 MPa	660 MPa	26 %
Stress relieved+ 4 hour(s) 735 °C	560 MPa	680 MPa	22 %

Typical Charpy V-Notch Properties

Condition	Testing Temperature	Impact Value
Ar (I1) EN		
Stress Relieved 2 hour(s) 760 °C	-20 °C	140 J
Stress relieved+ 4 hour(s) 735 °C	-20 °C	150 J
Stress Relieved 2 hour(s) 760 °C	-40 °C	120 J
Stress relieved+ 4 hour(s) 735 °C	-40 °C	130 J
Stress Relieved 2 hour(s) 760 °C	-60 °C	90 J
Stress relieved+ 4 hour(s) 735 °C	-60 °C	50 J

Typical Weld Metal Analysis %

C	Mn	Si	S	P	Cr	Mo
0.1	0.5	0.4	0.005	0.01	8.6	0.9

Typical Wire Composition %

C	Mn	Si	Ni	Cr	Mo
0.06	0.52	0.45	0.23	8.66	1.00

OK Tigrod 13.38

A non copper coated, low-alloyed, (9CrMoVN), rod for GTAW of high-temperature steels and steels for hot hydrogen service especially in oil refineries. Preferably used for 9 % Cr steels as e.g. P 91/T 91 steels. The alloy is modified as regards limits of impurity elements and is extremely "clean". This to receive improved strength levels both at room temperature and at higher temperatures. AWS have changed the classification for this product, earlier classification was A5.28 ER90S-B9.

Specifications	
Classifications	EN ISO 21952-A : W CrMo91 EN ISO 21952-B : W 62 I1 9C1MV SFA/AWS A5.28 : ER90S-B91
Approvals	CE : EN 13479 UKCA : EN 13479 VdTUV : 07686

Approvals are based on factory location. Please contact ESAB for more information.

Alloy Type	Alloyed steel (9 % Cr - 1 % Mo - V - N) "9CrMoVN"
Shielding Gas	I1 (EN ISO 14175)

Typical Tensile Properties				
Condition	Conditional Statement	Yield Strength	Tensile Strength	Elongation
Ar (I1) AWS				
PWHT 2 hour(s) 760 °C	Tested at 450°C	750 MPa	850 MPa	20 %
Ar (I1) EN				
PWHT (Tested)	Tested at 482°C	500 MPa	560 MPa	16 %
PWHT (Tested)	Tested at 450°C	510 MPa	580 MPa	14 %
Ar (I1) EN				
PWHT (Tested)	Tested at 560°C	420 MPa	450 MPa	22 %
PWHT (Tested)	Tested at 20°C	670 MPa	760 MPa	20 %
PWHT (Tested)	Tested at 20°C	690 MPa	785 MPa	20 %

Typical Charpy V-Notch Properties		
Condition	Testing Temperature	Impact Value
Ar (I1) AWS		
PWHT 2 hour(s) 760 °C	20 °C	95 J
Ar (I1) EN		
PWHT 4 hour(s) 735 °C	20 °C	210 J
PWHT 2 hour(s) 760 °C	20 °C	200 J
PWHT 2 hour(s) 760 °C	0 °C	180 J
PWHT 4 hour(s) 735 °C	0 °C	190 J
PWHT 4 hour(s) 735 °C	-20 °C	130 J
PWHT 2 hour(s) 760 °C	-20 °C	150 J

OK Tigrod 13.38

Typical Charpy V-Notch Properties

Condition	Testing Temperature	Impact Value
PWHT 4 hour(s) 735 °C	-40 °C	60 J
PWHT 2 hour(s) 760 °C	-40 °C	90 J
PWHT 4 hour(s) 735 °C	-60 °C	30 J
PWHT 2 hour(s) 760 °C	-60 °C	70 J

Typical Weld Metal Analysis %

C	Mn	Si	S	P	Ni	Cr	Mo	V	Cu
0.1	0.5	0.3	0.002	0.004	0.8	8.7	0.9	0.2	0.1

Typical Weld Metal Analysis %

N	Nb
0.04	0.06

Typical Wire Composition %

C	Mn	Si	Ni	Cr	Mo	V	N
0.1	0.5	0.3	0.5	8.7	0.9	0.20	0.05

OK Tigrod 55

A copper coated, low alloyed, chromium-nickel-molybdenum (0,5% Cr, 0,5% Ni, 0,2% Mo) rod for GTAW of high strength steels with a minimum tensile strength of 690 MPa. The rod is also suitable for welding of steels where a good impact strength at low temperatures is required.

Specifications	
Classifications	EN ISO 16834-A : W 55 4 Mn3NiCrMo EN ISO 16834-A : Mn3NiCrMo SFA/AWS A5.28 : ER100S-G
Approvals	CE : EN 13479 UKCA : EN 13479

Approvals are based on factory location. Please contact ESAB for more information.

Alloy Type	Low alloyed steel (0.5 % Cr - 0.5 % Ni - 0.2 % Mo)
Shielding Gas	I1 (EN ISO 14175)

Typical Tensile Properties			
Condition	Yield Strength	Tensile Strength	Elongation
Ar(I1) AWS			
As Welded	636 MPa	713 MPa	16 %
Ar (I1) EN			
As Welded	720 MPa	817 MPa	21 %
Stress Relieved 2 hour(s) 620 °C	629 MPa	716 MPa	23 %

Typical Charpy V-Notch Properties		
Condition	Testing Temperature	Impact Value
Ar(I1) AWS		
As Welded	-30 °C	120 J
As Welded	-40 °C	85 J
As Welded	-50 °C	80 J
Ar (I1) EN		
As Welded	-30 °C	125 J
Stress Relieved 2 hour(s) 620 °C	-30 °C	140 J
As Welded	-40 °C	120 J
Stress Relieved 2 hour(s) 620 °C	-40 °C	75 J
As Welded	-50 °C	75 J

Typical Weld Metal Analysis %								
C	Mn	Si	S	P	Ni	Cr	Mo	Cu
0.1	1.4	0.7	0.015	0.015	0.5	0.5	0.2	0.15

Typical Wire Composition %					
C	Mn	Si	Ni	Cr	Mo
0.118	1.38	0.71	0.52	0.57	0.19

OK Tigrod B2 SC

OK Tigrod B2 SC is a copper coated, low-alloyed, chromium-molybdenum solid wire designed for GTAW of creep resistant 1,25% Cr 0,5% Mo alloyed steels, SA-387 Grade 11, SA-182 Grade 11, SA-335 Grade P11 or similar materials when highest toughness values are required also after step cooling treatment. Very low level of impurity elements providing a X-bar max. 10 for temper embrittlement resistant applications. Usually welding is followed by a PWHT. Suitable for refinery, petrochemical and chemical industries, power generation, pressure vessels, etc.

Specifications

Classifications	EN ISO 21952-A : W Z CrMo1Si EN ISO 21952-B : W 55 11 1CM SFA/AWS A5.28 : ER80S-B2
Approvals	CE : EN 13479 UKCA : EN 13479

Approvals are based on factory location. Please contact ESAB for more information.

Alloy Type	Low alloyed (1,25% Cr, 0,5% Mo)
Shielding Gas	I1 (EN ISO 14175)

Typical Tensile Properties

Condition	Conditional Statement	Yield Strength	Tensile Strength	Elongation
Ar (I1) EN ISO				
PWHT 1 hour(s) 620 °C	-	650 MPa	740 MPa	25 %
Ar (I1) AWS				
PWHT 2 hour(s) 690 °C	-	500 MPa	610 MPa	30 %
PWHT 22 hour(s) 690 °C	Test temp. 450°C	375 MPa	430 MPa	21 %
PWHT 1 hour(s) 620 °C	-	590 MPa	685 MPa	28 %
PWHT 22 hour(s) 690 °C	-	420 MPa	540 MPa	32 %

Typical Charpy V-Notch Properties

Condition	Testing Temperature	Impact Value
Ar (I1) AWS		
PWHT 22 hour(s) 690 °C	-30 °C	300 J
PWHT 1 hour(s) 620 °C	-30 °C	300 J
PWHT 2 hour(s) 690 °C	-30 °C	300 J

Typical Weld Metal Analysis %

C	Mn	Si	S	P	Ni	Cr	Mo	V	Al
Ar									
0.073	0.52	0.55	0.005	0.005	0.05	1.3	0.52	0.005	0.003

Typical Weld Metal Analysis %

Cu	Nb	Ti	Sb	As	B	Sn	Mn+Si	Nb+Ti+V	P+Sn
Ar									
0.1	0.003	0.002	0.001	0.001	0.0001	0.002	1.07	0.010	0.007

OK Tigrod B2 SC

Typical Weld Metal Analysis %

PE	J-Factor	X-bar	Others tot
Ar			
2	80	6	<0.50

Typical Wire Composition %

C	Mn	Si	Ni	Cr	Mo
0.10	0.55	0.55	0.05	1.4	0.55

OK Tigrod B3 SC

OK Tigrod B3 SC is a copper coated, low-alloyed, chromium-molybdenum solid wire designed for GTAW of creep resistant 2,25% Cr 1% Mo alloyed steels, SA-387 Grade 22, A335 Grade P22 or similar materials when highest toughness values are required also after step cooling treatment. Very low level of impurity elements providing a X-bar max. 10 for temper embrittlement resistant applications. Usually welding is followed by a PWHT. Suitable for refinery, petrochemical and chemical industries, power generation, pressure vessels, etc.

Specifications

Classifications	EN ISO 21952-A : W Z CrMo2Si EN ISO 21952-B : W 62 2C1M SFA/AWS A5.28 : ER90S-B3
Approvals	CE : EN 13479 UKCA : EN 13479

Approvals are based on factory location. Please contact ESAB for more information.

Alloy Type	Low alloyed (2,25% Cr, 1% Mo)
Shielding Gas	I1 (EN ISO 14175)

Typical Tensile Properties

Condition	Yield Strength	Tensile Strength	Elongation
Ar (I1) EN ISO			
PWHT 1 hour(s) 720 °C	565 MPa	670 MPa	26 %
Ar (I1) AWS			
PWHT 32 hour(s) 690 °C	500 MPa	620 MPa	29 %
PWHT 1 hour(s) 690 °C	560 MPa	680 MPa	27 %
PWHT 4 hour(s) 690 °C	545 MPa	660 MPa	28 %
Ar (I1) AWS Test temp 460°C			
PWHT 32 hour(s) 690 °C	410 MPa	460 MPa	21 %

Typical Charpy V-Notch Properties

Condition	Testing Temperature	Impact Value
Ar (I1) EN ISO		
PWHT 1 hour(s) 720 °C	20 °C	275 J
Ar (I1) AWS		
PWHT 32 hour(s) 690 °C	-30 °C	190 J
PWHT 4 hour(s) 690 °C	-30 °C	170 J
PWHT 1 hour(s) 690 °C	-30 °C	155 J
PWHT 4 hour(s) 690 °C	-40 °C	160 J
PWHT 1 hour(s) 690 °C	-40 °C	150 J
PWHT 32 hour(s) 690 °C	-40 °C	140 J

OK Tigrod B3 SC

Typical Weld Metal Analysis %

C	Mn	Si	S	P	Ni	Cr	Mo	V	Al
0.07	0.52	0.5	0.005	0.005	0.1	2.5	1.0	0.010	0.002

Typical Weld Metal Analysis %

Cu	Nb	Ti	Sb	As	B	Sn	Mn+Si	Nb+Ti+V	P+Sn
0.1	0.005	0.003	0.002	0.002	0.0003	0.003	1.0	0.018	0.008

Typical Weld Metal Analysis %

PE	J-Factor	X-bar	Others tot
2.8	82	6	<0.5

Typical Wire Composition %

C	Mn	Si	Ni	Cr	Mo
0.08	0.5	0.5	0.05	2.4	1.0

Coreweld 46 LT H4

A metal cored wire designed for welding with Ar/CO₂ shielding gas mixture and for the welding of high strength steels with a minimum yield of 460MPa. Providing a very tough weld metal even down to low temperatures such as -60 degrees C.

Specifications

Classifications	SFA/AWS A5.28 : E80C-G H4 EN ISO 17632-A : T 46 6 Z M M21 2 H5
Approvals	ABS : 5YQ460 H5 ABS : 5YQ460SA H5 BV : S5Y46M H5 CE : EN 13479 DB : 42.039.46 DNV : V Y46MS(H5) DNV-GL : V Y46MS H5 LR : 5Y46S H5 UKCA : EN 13479 VdTÜV : 19850

Approvals are based on factory location. Please contact ESAB for more information.

Welding Current	DC+
Alloy Type	CMn
Shielding Gas	M21 (EN ISO 14175)

Typical Tensile Properties

Condition	Yield Strength	Tensile Strength	Elongation
M21			
As Welded	520 MPa	610 MPa	-
PWHT 2 hour(s) 620 °C	495 MPa	598 MPa	31 %

Typical Charpy V-Notch Properties

Condition	Testing Temperature	Impact Value
M21		
As Welded	-60 °C	94 J
PWHT 2 hour(s) 620 °C	-60 °C	91 J

Typical Weld Metal Analysis %

C	Mn	Si	Ni
M21 shielding gas.			
0.061	1.46	0.57	0.55

Deposition Data

Diameter	Current	Voltage	Wire Feed Speed	Deposition Rate
1.2 mm	90-380 A	14-35 V	2.0-18.5 m/min	1.0-8.9 kg/h
1.4 mm	105-390 A	14-34 V	1.6-12.0 m/min	1.0-8.0 kg/h

Coreweld 55 LT H4

A metal cored wire for the welding of high strength steels (>550 MPa) with excellent sub-zero toughness down to -60 degree C and low diffusible hydrogen levels. Suitable for welding with Ar/CO₂ gas mixtures.

Specifications	
Classifications	SFA/AWS A5.28 : E90C-G H4 EN ISO 18276-A : T 55 6 Z M21 2 H5
Approvals	CE : EN 13479 UKCA : EN 13479

Approvals are based on factory location. Please contact ESAB for more information.

Welding Current	DC+
Shielding Gas	M21 (EN ISO 14175)

Typical Tensile Properties			
Condition	Yield Strength	Tensile Strength	Elongation
As Welded	595 MPa	670 MPa	25 %

Typical Charpy V-Notch Properties		
Condition	Testing Temperature	Impact Value
As Welded	-60 °C	110 J

Typical Weld Metal Analysis %			
C	Mn	Si	Ni
0.05	1.65	0.44	1.35

Deposition Data				
Diameter	Current	Voltage	Wire Feed Speed	Deposition Rate
1.2 mm	100-320 A	16-32 V	1.8-12.0 m/min	1.3-7.5 kg/h
1.4 mm	120-380 A	16-34 V	2.0-9.0 m/min	1.6-7.5 kg/h
1.6 mm	140-450 A	18-36 V	1.5-8.5 m/min	1.6-8.0 kg/h

Coreweld 69 LT H4

A metal cored wire for the welding of high strength steels (>690 MPa) with excellent sub-zero toughness down to -60 degrees C and low diffusible hydrogen levels. Suitable for welding with Ar/CO₂ gas mixtures.

Specifications

Classifications	SFA/AWS A5.28 : E110C-G-H4 EN ISO 18276-A : T 69 6 Mn2NiMo M M21 2 H5 EN ISO 18276-B : T 76 6 T15 0M21A N4M2 U H5
Approvals	CE : EN 13479 DB : 42.039.47 UKCA : EN 13479 VdTÜV : 19912

Approvals are based on factory location. Please contact ESAB for more information.

Welding Current	DC+
Diffusible Hydrogen	< 4ml/100g
Alloy Type	C Mn, low alloy steel (2% Ni, 0.5% Mo)
Shielding Gas	M21 (EN ISO 14175)

Typical Tensile Properties

Condition	Yield Strength	Tensile Strength	Elongation
As Welded	755 MPa	790 MPa	20 %

Typical Charpy V-Notch Properties

Condition	Testing Temperature	Impact Value
As Welded	-60 °C	80 J

Typical Weld Metal Analysis %

C	Mn	Si	S	P	Ni	Cr	Mo	V	Cu
M21 shielding gas.									
0.05	1.7	0.5	0.008	0.011	2.30	0.06	0.50	0.01	0.012

Typical Weld Metal Analysis %

Nb
M21 shielding gas.
0.005

Deposition Data

Diameter	Current	Voltage	Wire Feed Speed	Deposition Rate
1.2 mm	100-320 A	16-32 V	1.8-12.0 m/min	1.3-7.5 kg/h
1.4 mm	120-380 A	16-34 V	2.0-9.0 m/min	1.6-7.5 kg/h
1.6 mm	140-450 A	18-36 V	1.5-8.5 m/min	1.6-8.0 kg/h

Coreweld 89

A metal cored wire for high strength applications (>890 MPa) developed for use with argon / carbon dioxide shielding gas. Optimal mechanical and welding results are achieved with Ar/8%CO₂ gas mixture. Excellent -40 degrees C toughness is achieved along with low diffusible hydrogen. The application area is anywhere where high strength steels are to be joined for example cranes, forestry machinery, load support and handling equipment.

Specifications	
Classifications	SFA/AWS A5.28 : E120C-G H4 EN ISO 18276-A : T 89 4 Z M M21 3 H5
Approvals	CE : EN 13479 UKCA : EN 13479

Approvals are based on factory location. Please contact ESAB for more information.

Welding Current	DC+
Diffusible Hydrogen	< 4 ml/100g
Alloy Type	C Mn, low alloy steel (Ni-Cr-Mo)
Shielding Gas	M20, M21 (EN ISO 14175)

Typical Tensile Properties			
Condition	Yield Strength	Tensile Strength	Elongation
M21 shielding gas			
As Welded	910 MPa	965 MPa	17 %
M20 shielding gas			
As Welded	931 MPa	993 MPa	17 %

Typical Charpy V-Notch Properties		
Condition	Testing Temperature	Impact Value
M21 shielding gas		
As Welded	-40 °C	95 J
M20 shielding gas		
As Welded	-40 °C	82 J

Typical Weld Metal Analysis %									
C	Mn	Si	S	P	Ni	Cr	Mo	V	Cu
M20 shielding gas									
0.105	1.32	0.53	0.010	0.008	2.49	0.58	0.71	0.01	0.01

Typical Weld Metal Analysis %	
Nb	
M20 shielding gas	
0.01	

Deposition Data				
Diameter	Current	Voltage	Wire Feed Speed	Deposition Rate
1.2 mm	100-360 A	16-32 V	1.8-13.0 m/min	1.3-8.0 kg/h

Dual Shield 55

An all-positional rutile cored wire for welding steels with a minimum yield strength of 550 MPa, for use with M21 shielding gas.

Specifications

Classifications	SFA/AWS A5.29 : E91T1-GM21 SFA/AWS A5.29 : E91T1-Ni1M21 EN ISO 18276-A : T 55 4 Z P M21 2 H5
Approvals	ABS : 4YQ500 SA H5 ABS : 4YQ500SA H5 CE : EN 13479 UKCA : EN 13479

Approvals are based on factory location. Please contact ESAB for more information.

Welding Current	DC+
Diffusible Hydrogen	< 5 ml/100g
Alloy Type	Low alloy steel (<1% Ni)
Shielding Gas	M21 (EN ISO 14175)

Typical Tensile Properties

Condition	Yield Strength	Tensile Strength	Elongation
M21 shielding gas			
As Welded	604 MPa	663 MPa	27 %

Typical Charpy V-Notch Properties

Condition	Testing Temperature	Impact Value
M21 shielding gas		
As Welded	-40 °C	106 J

Typical Weld Metal Analysis %

C	Mn	Si	Ni
M21 shielding gas			
0.05	1.45	0.41	0.95

Deposition Data

Diameter	Current	Voltage	Wire Feed Speed	Deposition Rate
1.2 mm	100-300 A	21-32 V	3.2-14.5 m/min	1.3-5.8 kg/h

Dual Shield 62

An all-positional rutile cored wire for welding steels with a minimum yield strength of 620 Mpa, for use with M21 shielding gas.

Specifications	
Classifications	SFA/AWS A5.29 : E101T1-G EN ISO 18276-A : T 62 4 Mn1.5Ni P M21 2 H5

Welding Current	DC+
Alloy Type	Low alloy
Shielding Gas	M21 (EN ISO 14175)

Typical Tensile Properties			
Condition	Yield Strength	Tensile Strength	Elongation
M21 shielding gas			
As Welded	670 MPa	740 MPa	24 %

Typical Charpy V-Notch Properties		
Condition	Testing Temperature	Impact Value
M21 shielding gas		
As Welded	-40 °C	95 J

Typical Weld Metal Analysis %			
C	Mn	Si	Ni
M21 shielding gas			
0.061	1.58	0.41	1.50

Deposition Data				
Diameter	Current	Voltage	Wire Feed Speed	Deposition Rate
1.2 mm	100-300 A	21-32 V	3.2-14.5 m/min	1.3-5.8 kg/h

Dual Shield 69

An all-positional rutile cored wire for welding high strength steel with a minimum yield strength of 690 MPa and excellent toughness down to -60°C. For use with M21 shielding gas.

Specifications

Classifications	SFA/AWS A5.29 : E111T1-GM EN ISO 18276-A : T 69 6 Z P M21 2 H5
Approvals	ABS : 4YQ690 SA H5 ABS : 4YQ690SA H5
Industry	Civil Construction Offshore Oil

Approvals are based on factory location. Please contact ESAB for more information.

Welding Current	DC+
Alloy Type	Low Alloy (Ni-Mo)
Shielding Gas	M21 (EN ISO 14175)

Typical Tensile Properties

Condition	Yield Strength	Tensile Strength	Elongation
PWHT 1 hour(s) 580 °C	806 MPa	848 MPa	20.2 %
As Welded	740 MPa	790 MPa	20 %

Typical Charpy V-Notch Properties

Condition	Testing Temperature	Impact Value
PWHT 1 hour(s) 580 °C	-30 °C	54 J
PWHT 1 hour(s) 580 °C	-40 °C	51 J
As Welded	-40 °C	65 J
PWHT 1 hour(s) 580 °C	-50 °C	54 J
PWHT 1 hour(s) 580 °C	-60 °C	44 J
As Welded	-60 °C	58 J

Typical Weld Metal Analysis %

C	Mn	Si	Ni	Mo
0.095	1.25	0.34	2.8	0.4

Deposition Data

Diameter	Current	Voltage	Wire Feed Speed	Deposition Rate
1.2 mm	150-350 A	21-32 V	5.6-19.8 m/min	2.1-7.5 kg/h

Dual Shield 110C

An all-positional rutile cored wire for welding high strength steel with a minimum yield strength of 690 MPa and toughness down to -60 degrees C for use with carbon dioxide shielding gas.

Specifications

Classifications	SFA/AWS A5.29 : E111T1 GC H4 EN ISO 18276-A : T 69 6 Z P C1 2 H5
------------------------	---

Welding Current	DC+
Alloy Type	Low Alloy (Ni Mo)
Shielding Gas	C1 (EN ISO 14175)

Typical Tensile Properties

Condition	Yield Strength	Tensile Strength	Elongation
C1 AWS			
As Welded	761 MPa	840 MPa	18 %

Typical Charpy V-Notch Properties

Condition	Testing Temperature	Impact Value
C1 AWS		
As Welded	-60 °C	60 J

Typical Weld Metal Analysis %

C	Mn	Si	Ni	Mo
C1 Shielding gas				
0.055	1.21	0.39	2.3	0.4

Deposition Data

Diameter	Current	Voltage	Wire Feed Speed	Deposition Rate
1.2 mm	100-300 A	21-32 V	3.2-14.5 m/min	1.3-5.8 kg/h

Dual Shield CrMo1

Dual Shield CrMo1 is an all positional rutile, low-hydrogen flux-cored wires for welding 1.25%Cr creep resisting steels. Designed for use in Ar/CO₂ shielding gas, it has excellent weldability and produce flat beads with good wetting and appearance as well as good impact toughness down to -20°C after stress relieving

Specifications

Classifications	SFA/AWS A5.29 : E81T1-B2M EN ISO 17634-A : T CrMo1 P M 2 H5
Approvals	VdTÜV : 12138

Approvals are based on factory location. Please contact ESAB for more information.

Welding Current	DC+
Alloy Type	1Cr 0.5Mo
Shielding Gas	M21 (EN ISO 14175)

Typical Tensile Properties

Condition	Yield Strength	Tensile Strength	Elongation
PWHT 1 hour(s) 690 °C	563 MPa	626 MPa	27 %

Typical Charpy V-Notch Properties

Condition	Testing Temperature	Impact Value
PWHT 1 hour(s) 690 °C	20 °C	156 J
PWHT 1 hour(s) 690 °C	0 °C	149 J
PWHT 1 hour(s) 690 °C	-20 °C	55 J

Typical Weld Metal Analysis %

C	Mn	Si	Cr	Mo
0.06	0.90	0.35	1.29	0.54

Deposition Data

Diameter	Current	Voltage	Wire Feed Speed	Deposition Rate
1.2 mm	150-350 A	23-35 V	5.8-20.7 m/min	2.1-7.5 kg/h

Dual Shield CrMo2

Dual Shield CrMo2 is an all position rutile, low-hydrogen flux-cored wires for welding 2.25%Cr/1%Mo creep resisting steels. Designed for use in Ar/CO₂ shielding gas, it has excellent weldability and produce flat beads with good wetting and appearance with good impact toughness down to -20 °C after stress relieving.

Specifications

Classifications	SFA/AWS A5.29 : E91T1-B3M EN ISO 17634-A : T CrMo2 P M 2 H5
------------------------	--

Welding Current	DC+
Alloy Type	2Cr 1Mo
Shielding Gas	M21 (EN ISO 14175)

Typical Tensile Properties

Condition	Yield Strength	Tensile Strength	Elongation
PWHT 1 hour(s) 690 °C	625 MPa	710 MPa	20 %

Typical Charpy V-Notch Properties

Condition	Testing Temperature	Impact Value
PWHT 1 hour(s) 690 °C	20 °C	130 J
PWHT 1 hour(s) 690 °C	0 °C	110 J
PWHT 1 hour(s) 690 °C	-20 °C	65 J

Typical Weld Metal Analysis %

C	Mn	Si	Cr	Mo
0.06	0.84	0.33	2.26	0.94

Deposition Data

Diameter	Current	Voltage	Wire Feed Speed	Deposition Rate
1.2 mm	150-350 A	23-35 V	5.8-20.7 m/min	2.1-7.5 kg/h

Dual Shield MoL

Dual Shield MoL is an all position rutile, low-hydrogen flux-cored wires for welding 0.5%Mo creep resisting steels. Designed for use in Ar/CO₂ shielding gas, it has excellent weldability and produce flat beads with good wetting and appearance with good impact toughness down to -20 °C after stress relieving.

Specifications

Classifications	SFA/AWS A5.29 : E81T1-A1M EN ISO 17634-A : T MoL P M 2 H5
Approvals	VdTÜV : 12161

Approvals are based on factory location. Please contact ESAB for more information.

Welding Current	DC+
Alloy Type	0.5Mo
Shielding Gas	M21 (EN ISO 14175)

Typical Tensile Properties

Condition	Yield Strength	Tensile Strength	Elongation
M21 Shielding gas			
PWHT 1 hour(s) 615 °C	563 MPa	626 MPa	27 %

Typical Charpy V-Notch Properties

Condition	Testing Temperature	Impact Value
M21 Shielding gas		
PWHT 1 hour(s) 615 °C	20 °C	156 J
PWHT 1 hour(s) 615 °C	0 °C	149 J
PWHT 1 hour(s) 615 °C	-20 °C	131 J

Typical Weld Metal Analysis %

C	Mn	Si	Mo
0.043	0.72	0.25	0.47

Deposition Data

Diameter	Current	Voltage	Wire Feed Speed	Deposition Rate
1.2 mm	150-350 A	23-35 V	5.8-20.7 m/min	2.1-7.5 kg/h

Dual Shield Prime 81Ni1 H4

A seamless, copper free, cored wire designed to weld thick steel components. The diffusible hydrogen level is consistently below 4ml/100g of deposited weld metal and with the seam of the wire being laser welded this ensures no moisture pick up. The wire is not copper coated which means there is no chance of copper flakes contaminating feed liners, torches and contact tips. Dual Shield Prime 81Ni1 H4 is designed to weld high strength steels (>500 MPa, >72 ksi yield strength) and provides excellent impact toughness down to -60 degrees C. Dual Shield Prime 81Ni1 H4 is designed to be used with CO₂ (C1) shielding gas mixture.

Specifications	
Classifications	EN ISO 17632-B : T556T1-1CA-N2-U-H5 SFA/AWS A5.29 : E81T1-Ni1C H4 EN ISO 17632-A : T 50 6 1Ni P C1 1 H5
Approvals	ABS : 5YQ460SA H5 BV : SA5Y46 H5 CE : EN 13479 DNV-GL : V Y46MS(H5) LR : 5Y46S H5 RS : 5Y46S H5 UKCA : EN 13479

Approvals are based on factory location. Please contact ESAB for more information.

Welding Current	DC+
Diffusible Hydrogen	< 4 ml/100g
Alloy Type	C Mn Ni
Shielding Gas	C1 (EN ISO 14175)

Typical Tensile Properties			
Condition	Yield Strength	Tensile Strength	Elongation
C1 Shielding gas			
As Welded	525 MPa	605 MPa	27 %

Typical Charpy V-Notch Properties		
Condition	Testing Temperature	Impact Value
C1 Shielding gas		
As Welded	-40 °C	120 J
As Welded	-60 °C	65 J

Typical Weld Metal Analysis %			
C	Mn	Si	Ni
C1 Shielding gas			
0.04	1.30	0.25	0.92

Deposition Data				
Diameter	Current	Voltage	Wire Feed Speed	Deposition Rate
1.2 mm	170-310 A	23-35 V	6.0-16.5 m/min	2.5-6.2 kg/h
1.4 mm	180-400 A	23-38 V	4.0-13.5 m/min	2.6-7.1 kg/h
1.6 mm	180-420 A	24-38 V	3.0-13.0 m/min	1.8-7.5 kg/h

Dual Shield Prime 81Ni1M H4

A seamless, copper free, cored wire designed to weld thick steel components. The diffusible hydrogen level is consistently below 4ml/100g of deposited weld metal and with the seam of the wire being laser welded this ensures no moisture pick up. The wire is not copper coated which means there is no chance of copper flakes contaminating feed liners, torches and contact tips. Dual Shield Prime 81Ni1M H4 is designed to weld high strength steels (>500 MPa, >72 ksi yield strength) and provides excellent impact toughness down to -60 degrees C. Dual Shield Prime 81Ni1M H4 is designed to be used with Ar/CO₂ (M21) shielding gas mixtures.

Specifications

Classifications	EN ISO 17632-B : T555T1-1M21A-N2-U-H5 SFA/AWS A5.29 : E81T1-Ni1M H4 EN ISO 17632-A : T 50 6 1Ni P M21 1 H5
Approvals	ABS : 5YQ460SA H5 BV : SA5Y46 H5 CE : EN 13479 DNV-GL : V Y46MS(H5) LR : 5Y46S H5 UKCA : EN 13479

Approvals are based on factory location. Please contact ESAB for more information.

Welding Current	DC+
Diffusible Hydrogen	< 4 ml/100g
Alloy Type	C Mn Ni
Shielding Gas	M21 (EN ISO 14175)

Typical Tensile Properties

Condition	Yield Strength	Tensile Strength	Elongation
M21 Shielding gas			
As Welded	533 MPa	587 MPa	28 %

Typical Charpy V-Notch Properties

Condition	Testing Temperature	Impact Value
M21 Shielding gas		
As Welded	-40 °C	110 J
As Welded	-60 °C	75 J

Typical Weld Metal Analysis %

C	Mn	Si	Ni
M21 Shielding gas			
0.03	1.34	0.29	0.96

Deposition Data

Diameter	Current	Voltage	Wire Feed Speed	Deposition Rate
1.2 mm	170-310 A	23-35 V	6.0-16.5 m/min	2.5-6.2 kg/h
1.6 mm	180-420 A	24-38 V	3.0-13.0 m/min	1.8-7.5 kg/h

FILARC PZ6112

An all positional rutile cored wire for weathering steels, used with C1 or M21 shielding gas.

Specifications	
Classifications	SFA/AWS A5.29 : E71T1-G H4 SFA/AWS A5.29 : E81T1-GM H8 EN ISO 17632-A : T 42 2 Z P C1 1 H5 EN ISO 17632-A : T 46 2 Z P M21 1 H5
Approvals	CE : EN 13479 DB : 42.105.13 UKCA : EN 13479 VdTUV : 06767

Approvals are based on factory location. Please contact ESAB for more information.

Welding Current	DC+
Alloy Type	Low alloy

Typical Tensile Properties			
Condition	Yield Strength	Tensile Strength	Elongation
M21 shielding gas			
As Welded	541 MPa	620 MPa	24.6 %

Typical Charpy V-Notch Properties		
Condition	Testing Temperature	Impact Value
M21 shielding gas		
As Welded	-20 °C	66 J

Typical Weld Metal Analysis %				
C	Mn	Si	Ni	Cu
0.065	1.07	0.66	0.66	0.42

Deposition Data				
Diameter	Current	Voltage	Wire Feed Speed	Deposition Rate
1.2 mm	150-350 A	27-38 V	5.8-20.7 m/min	2.1-7.5 kg/h

FILARC PZ6114

An all-positional rutile cored wire with excellent toughness down to low, sub-zero temperatures, for use with M21 shielding gas

Specifications

Classifications	EN ISO 17632-B : T 55 5 T12-1 M21 A-U H5 SFA/AWS A5.20 : E71T-1MJ H4 EN ISO 17632-A : T 46 5 P M21 1 H5
Approvals	ABS : 4Y400SA H5 BV : S4Y40 H5 CE : EN 13479 CRS : 4YH5S DB : 42.105.16 DNV : IV Y40MS(H5) LR : 3YM H5 LR : 3YS H5 PRS : 3YS H5 UKCA : EN 13479 VdTÜV : 07669

Approvals are based on factory location. Please contact ESAB for more information.

Welding Current	DC+
Alloy Type	CMn

Typical Tensile Properties

Condition	Yield Strength	Tensile Strength	Elongation
M21 shielding gas			
As Welded	529 MPa	586 MPa	25.5 %

Typical Charpy V-Notch Properties

Condition	Testing Temperature	Impact Value
M21 shielding gas		
As Welded	-40 °C	130 J
As Welded	-50 °C	124 J

Typical Weld Metal Analysis %

C	Mn	Si	Ni
M21 shielding gas			
0.056	1.25	0.41	0.41

Deposition Data

Diameter	Current	Voltage	Wire Feed Speed	Deposition Rate
1.0 mm	100-300 A	25-35 V	4.5-23.0 m/min	1.2-6.2 kg/h
1.2 mm	150-350 A	27-35 V	5.6-19.8 m/min	2.1-7.5 kg/h

FILARC PZ6115

An all-positional rutile cored wire for use with mixed gas providing very good toughness down to -50 °C.

Specifications	
Classifications	EN ISO 17632-A : T 50 5 2Ni P M21 2 H5
Approvals	BV : SA5Y50M H5 DNV : V Y50MS(H5)

Approvals are based on factory location. Please contact ESAB for more information.

Welding Current	DC+
Alloy Type	Low alloy
Shielding Gas	M21 (EN ISO 14175)

Typical Tensile Properties			
Condition	Yield Strength	Tensile Strength	Elongation
M21 shielding gas			
As Welded	557 MPa	662 MPa	21 %

Typical Charpy V-Notch Properties		
Condition	Testing Temperature	Impact Value
M21 shielding gas		
As Welded	-50 °C	93 J

Typical Weld Metal Analysis %			
C	Mn	Si	Ni
M21 shielding gas			
0.054	1.06	0.39	2.36

Deposition Data				
Diameter	Current	Voltage	Wire Feed Speed	Deposition Rate
1.2 mm	150-350 A	27-35 V	5.6-19.8 m/min	2.1-7.5 kg/h

FILARC PZ6116S

An all-positional rutile cored wire with good toughness down to -60 °C for use with carbon dioxide shielding gas.

Specifications

Classifications	SFA/AWS A5.29 : E81T1-K2 C JH4 EN ISO 17632-A : T 46 6 1.5Ni P C1 1 H5
Approvals	ABS : 3SA H5, 3YSA H5 ABS : 4YQ420SA H5 BV : S5Y46H5 CE : EN 13479 DNV-GL : V Y46MS(H5) LR : 5Y40M H5 LR : 5Y40S H5 PRS : 3YS H5 RINA : 4Y S UKCA : EN 13479

Approvals are based on factory location. Please contact ESAB for more information.

Welding Current	DC+
Alloy Type	Low Alloy
Shielding Gas	C1 (EN ISO 14175)

Typical Tensile Properties

Condition	Yield Strength	Tensile Strength	Elongation
As Welded	553 MPa	624 MPa	24 %

Typical Charpy V-Notch Properties

Condition	Testing Temperature	Impact Value
As Welded	-60 °C	69 J

Typical Weld Metal Analysis %

C	Mn	Si	Ni
0.054	1.38	0.43	1.42

Deposition Data

Diameter	Current	Voltage	Wire Feed Speed	Deposition Rate
1.2 mm	150-350 A	23-35 V	5.6-19.8 m/min	2.1-7.5 kg/h
1.6 mm	150-450 A	24-36 V	2.8-12.4 m/min	1.8-8.1 kg/h

FILARC PZ6125

A basic cored wire which gives good toughness down to -60 °C for use with M21 shielding gas. Diameters less than 1.4mm are all-positional.

Specifications	
Classifications	SFA/AWS A5.29 : E71T5-K6M H4 EN ISO 17632-A : T 42 6 1Ni B M21 1 H5
Approvals	ABS : 3SA, 3YSA H5 ABS : 3YSA H5 BV : S5YMH5 BV : S4M, S5YM H5 (M21) CE : EN 13479 DB : 42.105.12 DNV : V Y40MS(H5) LR : 5Y40S H5 UKCA : EN 13479 VdTÜV : 05648

Approvals are based on factory location. Please contact ESAB for more information.

Welding Current	DC-(+)
Alloy Type	Low alloy
Shielding Gas	M21 (EN ISO 14175)

Typical Tensile Properties			
Condition	Yield Strength	Tensile Strength	Elongation
M21 shielding gas			
As Welded	445 MPa	556 MPa	28.4 %
Stress Relieved 2 hour(s) 600 °C	410 MPa	510 MPa	28 %

Typical Charpy V-Notch Properties		
Condition	Testing Temperature	Impact Value
M21 shielding gas		
Stress Relieved 2 hour(s) 600 °C	-40 °C	100 J
As Welded	-60 °C	109 J
Stress Relieved 2 hour(s) 600 °C	-60 °C	60 J

Typical Weld Metal Analysis %			
C	Mn	Si	Ni
M21 shielding gas			
0.084	1.24	0.45	0.85

Deposition Data				
Diameter	Current	Voltage	Wire Feed Speed	Deposition Rate
1.0 mm	100-250 A	16-31 V	5.6-18.6 m/min	1.4-4.7 kg/h
1.2 mm	150-350 A	20-35 V	5.8-22.0 m/min	2.1-7.9 kg/h
1.6 mm	150-450 A	18-36 V	2.8-12.0 m/min	1.8-7.9 kg/h

FILARC PZ6138

An all-positional rutile cored wire for use with M21 providing very good toughness down to -60 °C.

Specifications

Classifications	EN ISO 17632-B : T 55 5 T1 M A N2 U H5 SFA/AWS A5.29 : E81T1-Ni1M JH4 EN ISO 17632-A : T 50 6 1Ni P M21 1 H5
Approvals	ABS : 3SA 3YSA H5 BV : S3YM H5 CE : EN 13479 DB : 42.105.08 DNV : V Y46MS(H5) LR : 5Y40M H5 LR : 5Y40S H5 LR : 5Y42S H5 PRS : 5Y40S H5 UKCA : EN 13479 VdTUV : 04903

Approvals are based on factory location. Please contact ESAB for more information.

Welding Current	DC+
Alloy Type	Low alloy
Shielding Gas	M21 (EN ISO 14175)

Typical Tensile Properties

Condition	Yield Strength	Tensile Strength	Elongation
M21			
As Welded	577 MPa	616 MPa	29 %

Typical Charpy V-Notch Properties

Condition	Testing Temperature	Impact Value
M21		
As Welded	-20 °C	145 J
As Welded	-40 °C	130 J
As Welded	-60 °C	114 J

Typical Weld Metal Analysis %

C	Mn	Si	Ni	Cu
M21				
0.04	1.1	0.33	0.93	0.021

Deposition Data

Diameter	Current	Voltage	Wire Feed Speed	Deposition Rate
1.2 mm	150-350 A	20-35 V	5.8-22.0 m/min	2.1-7.9 kg/h
1.4 mm	150-350 A	26-34 V	3.2-11.1 m/min	1.8-6.3 kg/h
1.6 mm	150-450 A	24-36 V	2.6-11.9 m/min	1.8-8.1 kg/h

FILARC PZ6138SR

An all-positional rutile cored wire for use with M21 providing very good toughness down to -60 °C after stress relief.

Specifications	
Classifications	SFA/AWS A5.29 : E81T1-Ni1M J H4 EN ISO 17632-A : T 46 6 1Ni P M21 1 H5
Approvals	ABS : 4YSA H5 DNV : V Y42MS H5 LR : 5Y42S H5 LR : 5Y42srS H5

Approvals are based on factory location. Please contact ESAB for more information.

Welding Current	DC+
Alloy Type	Low alloy
Shielding Gas	M21 (EN ISO 14175)

Typical Tensile Properties			
Condition	Yield Strength	Tensile Strength	Elongation
M21			
Stress Relieved 2 hour(s) 600 °C	505 MPa	585 MPa	25 %

Typical Charpy V-Notch Properties		
Condition	Testing Temperature	Impact Value
M21		
Stress Relieved 2 hour(s) 600 °C	-60 °C	84 J

Typical Weld Metal Analysis %			
C	Mn	Si	Ni
0.048	1.24	0.37	0.84

Deposition Data				
Diameter	Current	Voltage	Wire Feed Speed	Deposition Rate
1.2 mm	175-350 A	25-38 V	5.6-12.8 m/min	2.8-8.1 kg/h

FILARC PZ6138S SR

An all-positional rutile cored wire for use with carbon dioxide shielding gas, providing very good toughness down to -60 °C after stress relief.

Specifications	
Classifications	SFA/AWS A5.29 : E81T1-Ni1C J EN ISO 17632-A : T 46 6 1Ni P C1 1 H5
Approvals	ABS : 5Y42M H5 ABS : 5Y46M H5 BV : 5Y42 H5 (C1) BV : 5Y46 H5 (C1) CE : EN 13479 DNV-GL : V Y42MS (H5) (C1) DNV-GL : V Y46MS (H5) (C1) UKCA : EN 13479

Approvals are based on factory location. Please contact ESAB for more information.

Welding Current	DC+
Alloy Type	Low alloy
Shielding Gas	C1 (EN ISO 14175)

Typical Tensile Properties			
Condition	Yield Strength	Tensile Strength	Elongation
C1 Shielding gas			
As Welded	498 MPa	579 MPa	28 %
Stress Relieved 2 hour(s) 600 °C	480 MPa	560 MPa	25 %
C1 shielding gas			
As Welded	498 MPa	579 MPa	28 %
Stress Relieved 2 hour(s) 600 °C	480 MPa	560 MPa	25 %

Typical Charpy V-Notch Properties		
Condition	Testing Temperature	Impact Value
C1 Shielding gas		
As Welded	-60 °C	90 J
Stress Relieved 2 hour(s) 600 °C	-60 °C	83 J
C1 shielding gas		
As Welded	-60 °C	90 J
Stress Relieved 2 hour(s) 600 °C	-60 °C	83 J

Typical Weld Metal Analysis %			
C	Mn	Si	Ni
C1 Shielding gas			
0.05	1.3	0.30	0.90

Deposition Data				
Diameter	Current	Voltage	Wire Feed Speed	Deposition Rate
1.2 mm	175-350 A	25-38 V	5.6-12.8 m/min	2.8-8.1 kg/h

FILARC PZ6222

An all-positional rutile cored wire for 0.5% Mo creep resisting steels used with M21 shielding gas.

Specifications

Classifications	SFA/AWS A5.29 : E81T1-A1M H4 EN ISO 17634-A : T MoL P M 2 H5
Approvals	VdTÜV : 07071

Approvals are based on factory location. Please contact ESAB for more information.

Welding Current	DC+
Alloy Type	Low alloy (0.5% Mo)
Shielding Gas	M21 (EN ISO 14175)

Typical Tensile Properties

Condition	Yield Strength	Tensile Strength	Elongation
M21 shielding gas			
As Welded	573 MPa	635 MPa	24 %
PWHT 1 hour(s) 610 °C	533 MPa	592 MPa	24.1 %

Typical Charpy V-Notch Properties

Condition	Testing Temperature	Impact Value
M21 shielding gas		
As Welded	20 °C	75 J
PWHT 1 hour(s) 610 °C	20 °C	69 J

Typical Weld Metal Analysis %

C	Mn	Si	Mo
M21 shielding gas			
0.036	0.76	0.41	0.47

Deposition Data

Diameter	Current	Voltage	Wire Feed Speed	Deposition Rate
1.2 mm	150-350 A	27-35 V	5.6-19.8 m/min	2.1-7.5 kg/h

OK Tubrod 14.01

A 0.5% Cu metal cored wire for use with M21 shielding gas.

Specifications

Classifications	SFA/AWS A5.18 : E70C-GM EN ISO 17632-A : T 42 2 Z M M21 2 H5
Approvals	CE : EN 13479 UKCA : EN 13479

Approvals are based on factory location. Please contact ESAB for more information.

Welding Current	DC+-
Diffusible Hydrogen	<4 ml/100g
Alloy Type	Low alloy (0.5% Cu).
Shielding Gas	M21 (EN ISO 14175)

Typical Tensile Properties

Condition	Yield Strength	Tensile Strength	Elongation
M21 shielding gas			
As Welded	489 MPa	595 MPa	26 %

Typical Charpy V-Notch Properties

Condition	Testing Temperature	Impact Value
M21 shielding gas		
As Welded	-20 °C	98 J

Typical Weld Metal Analysis %

C	Mn	Si	Cu
M21 shielding gas			
0.07	1.35	0.58	0.53

Deposition Data

Diameter	Current	Voltage	Wire Feed Speed	Deposition Rate
1.2 mm	100-320 A	16-32 V	1.8-12.0 m/min	1.3-7.5 kg/h

OK Tubrod 14.02

A 0.5% Mo metal cored wire for use with M21 shielding gas. Diameters less than 1.4mm are all-positional.

Specifications	
Classifications	SFA/AWS A5.28 : E80C-G EN ISO 17632-A : T 50 2 Z M M21 2 H5
Approvals	CE : EN 13479 DB : 42.039.34 UKCA : EN 13479 VdTUV : 10716

Approvals are based on factory location. Please contact ESAB for more information.

Welding Current	DC+-
Diffusible Hydrogen	< 4 ml/100g
Alloy Type	C Mn low alloy steel (0.5 % Mo).
Shielding Gas	M21 (EN ISO 14175)

Typical Tensile Properties			
Condition	Yield Strength	Tensile Strength	Elongation
M21 shielding gas			
As Welded	588 MPa	663 MPa	25 %

Typical Charpy V-Notch Properties		
Condition	Testing Temperature	Impact Value
M21 shielding gas		
As Welded	-20 °C	79 J

Typical Weld Metal Analysis %			
C	Mn	Si	Mo
M21 shielding gas			
0.06	1.27	0.58	0.51

Deposition Data				
Diameter	Current	Voltage	Wire Feed Speed	Deposition Rate
1.2 mm	100-320 A	16-32 V	1.8-12.0 m/min	1.3-7.5 kg/h
1.6 mm	140-450 A	18-36 V	1.5-8.5 m/min	1.6-8.0 kg/h

OK Tubrod 14.03

A metal cored wire for high strength applications (>690 Mpa) for use with M21 shielding gas. Diameters less than 1.4mm are all-positional except vertical down.

Specifications	
Classifications	SFA/AWS A5.28 : E110C-G SFA/AWS A5.29 : E111TG-K3 EN ISO 18276-A : T 69 4 Mn2NiMo M M21 2 H5
Approvals	CE : EN 13479 DB : 42.039.23 UKCA : EN 13479 VdTUV : 04142

Approvals are based on factory location. Please contact ESAB for more information.

Welding Current	DC+-
Diffusible Hydrogen	< 5ml/100g
Alloy Type	C Mn, low alloy steel (2% Ni, 0.5% Mo)
Shielding Gas	M21 (EN ISO 14175)

Typical Tensile Properties			
Condition	Yield Strength	Tensile Strength	Elongation
M21			
As Welded	757 MPa	842 MPa	20 %

Typical Charpy V-Notch Properties		
Condition	Testing Temperature	Impact Value
M21		
As Welded	-40 °C	71 J

Typical Weld Metal Analysis %				
C	Mn	Si	Ni	Mo
M21 shielding gas				
0.07	1.60	0.50	2.25	0.56

Deposition Data				
Diameter	Current	Voltage	Wire Feed Speed	Deposition Rate
1.2 mm	100-320 A	16-32 V	1.8-12.0 m/min	1.3-7.5 kg/h
1.4 mm	120-380 A	16-34 V	2.0-9.0 m/min	1.6-7.5 kg/h
1.6 mm	140-450 A	18-36 V	1.5-8.5 m/min	1.6-8.0 kg/h

OK Tubrod 14.04

A 2% Ni metal cored wire which gives good toughness down to -60 degrees C using M21 shielding gas. All-positional except vertical down.

Specifications	
Classifications	SFA/AWS A5.28 : E70C-G EN ISO 17632-A : T 42 6 2Ni M M21 2 H5
Approvals	ABS : 3YSA H10 CE : EN 13479 DNV : V YMS(H10) LR : 5Y40S H5 (M21) UKCA : EN 13479 VdTÜV : 04304

Approvals are based on factory location. Please contact ESAB for more information.

Welding Current	DC+-
Diffusible Hydrogen	< 5 ml/100g
Alloy Type	Low alloy steel - (2% Ni)
Shielding Gas	M21 (EN ISO 14175)

Typical Tensile Properties			
Condition	Yield Strength	Tensile Strength	Elongation
M21 shielding gas			
As Welded	460 MPa	570 MPa	26 %

Typical Charpy V-Notch Properties		
Condition	Testing Temperature	Impact Value
M21 shielding gas		
As Welded	-20 °C	141 J
As Welded	-60 °C	78 J

Typical Weld Metal Analysis %			
C	Mn	Si	Ni
M21 shielding gas			
0.05	0.98	0.40	2.26

Deposition Data				
Diameter	Current	Voltage	Wire Feed Speed	Deposition Rate
1.2 mm	100-320 A	16-32 V	1.8-12.0 m/min	1.3-7.5 kg/h
1.4 mm	120-380 A	16-34 V	2.0-9.0 m/min	1.6-7.5 kg/h

OK Tubrod 14.05

A 1% Ni metal cored wire which gives good toughness down to -40 degrees C using M21 shielding gas.

Specifications

Classifications	SFA/AWS A5.28 : E70C-GM EN ISO 17632-A : T 42 4 Z M M21 2 H5
Approvals	ABS : 3YSA H10 (M21) BV : SA3YM HH (M21) CE : EN 13479 DNV : III YMS(H10) LR : 4Y40S H5 (M21) UKCA : EN 13479

Approvals are based on factory location. Please contact ESAB for more information.

Welding Current	DC+-
Diffusible Hydrogen	<5 ml/100g
Alloy Type	Low alloy steel - (1% Ni)
Shielding Gas	M21 (EN ISO 14175)

Typical Tensile Properties

Condition	Yield Strength	Tensile Strength	Elongation
M21 shielding gas			
As Welded	501 MPa	601 MPa	27 %

Typical Charpy V-Notch Properties

Condition	Testing Temperature	Impact Value
M21 shielding gas		
As Welded	-20 °C	110 J
As Welded	-40 °C	80 J

Typical Weld Metal Analysis %

C	Mn	Si	Ni
M21 shielding gas			
0.05	1.36	0.52	0.91

Deposition Data

Diameter	Current	Voltage	Wire Feed Speed	Deposition Rate
1.0 mm	80-250 A	14-30 V	2.5-10.0 m/min	1.2-4.2 kg/h
1.2 mm	100-320 A	16-32 V	1.8-12.0 m/min	1.3-7.5 kg/h

OK Tubrod 15.09

An all-positional rutile cored wire for welding high strength steel with a minimum yield strength of 690 MPa for use with M21 shielding gas.

Specifications	
Classifications	SFA/AWS A5.29 : E111T1-K3MJ-H4 EN ISO 18276-A : T 69 4 2NiMo P M21 2 H5
Approvals	CE : EN 13479 UKCA : EN 13479 VdTÜV : 10733

Approvals are based on factory location. Please contact ESAB for more information.

Welding Current	DC+
Alloy Type	Low Alloy (Ni Mo)
Shielding Gas	M21 (EN ISO 14175)

Typical Tensile Properties			
Condition	Yield Strength	Tensile Strength	Elongation
M21 shielding gas			
As Welded	761 MPa	840 MPa	20 %

Typical Charpy V-Notch Properties		
Condition	Testing Temperature	Impact Value
M21 shielding gas		
As Welded	-40 °C	60 J

Typical Weld Metal Analysis %				
C	Mn	Si	Ni	Mo
0.055	1.21	0.39	2.3	0.4

Deposition Data				
Diameter	Current	Voltage	Wire Feed Speed	Deposition Rate
1.2 mm	150-350 A	21-32 V	5.6-19.8 m/min	2.1-7.5 kg/h

OK Tubrod 15.11

An all-positional rutile cored wire with good toughness down to -60 °C for the use with M21 shielding gas. Diameters less than 1.4mm are all-positional except vertical down.

Specifications	
Classifications	SFA/AWS A5.29 : E81T1-Ni2M EN ISO 17632-A : T 50 6 2Ni P M21 2 H5
Approvals	CE : EN 13479 DNV-GL : IV Y46MS H5 (M21) LR : 4Y46S H5 (M21) UKCA : EN 13479

Approvals are based on factory location. Please contact ESAB for more information.

Welding Current	DC+
Diffusible Hydrogen	< 5 ml/100g
Alloy Type	Low alloy (2.5% Ni)
Shielding Gas	M21 (EN ISO 14175)

Typical Tensile Properties			
Condition	Yield Strength	Tensile Strength	Elongation
M21 Shielding gas			
As Welded	576 MPa	606 MPa	24 %

Typical Charpy V-Notch Properties		
Condition	Testing Temperature	Impact Value
M21 Shielding gas		
As Welded	-60 °C	92 J

Typical Weld Metal Analysis %			
C	Mn	Si	Ni
M21 shielding gas			
0.04	0.86	0.32	2.20

Deposition Data				
Diameter	Current	Voltage	Wire Feed Speed	Deposition Rate
1.2 mm	110-300 A	21-32 V	3.2-14.5 m/min	1.3-5.8 kg/h

OK Tubrod 15.17

An positional rutile cored wire for use with M21 or C1 gas, providing very good toughness down to -40°C. The 1.2mm diameter is all-positional except vertical down.

Specifications	
Classifications	SFA/AWS A5.29 : E81T1-Ni1MJ SFA/AWS A5.29 : E81T1-Ni1CJ H4 EN ISO 17632-A : T 46 3 1Ni P C1 2 H5 EN ISO 17632-A : T 46 4 1Ni P M21 2 H5
Approvals	ABS : 3YSA H5 (C1) ABS : 3YSA H5 (M21) BV : SA3YM (M21) BV : SA3YM HH (C1) CE : EN 13479 DB : 42.039.26 DNV : IV Y46MS(H5) LR : 3YS H5 (C1) LR : 4Y46S H5 (M21) RINA : 4Y46S H5 (M21) UKCA : EN 13479 VdTÜV : 05198

Approvals are based on factory location. Please contact ESAB for more information.

Welding Current	DC+
Diffusible Hydrogen	< 5 ml/100g (M21 gas) < 4 ml/100g (C1 gas)
Alloy Type	Low alloy steel (1% Ni)
Shielding Gas	M21, C1 (EN ISO 14175)

Typical Tensile Properties			
Condition	Yield Strength	Tensile Strength	Elongation
M21 EN			
As Welded	544 MPa	613 MPa	26 %

Typical Charpy V-Notch Properties		
Condition	Testing Temperature	Impact Value
M21 EN		
As Welded	-40 °C	124 J

Typical Weld Metal Analysis %			
C	Mn	Si	Ni
M21 shielding gas			
0.05	1.15	0.34	0.96

Deposition Data				
Diameter	Current	Voltage	Wire Feed Speed	Deposition Rate
1.2 mm	110-300 A	21-32 V	3.2-14.5 m/min	1.3-5.8 kg/h
1.6 mm	150-360 A	24-34 V	3.0-11.0 m/min	2.0-6.2 kg/h

OK Tubrod 15.19

An all-positional rutile cored wire for welding steels with a minimum yield strength of 550 Mpa, for use with M21 shielding gas.

Specifications	
Classifications	SFA/AWS A5.29 : E81T1-Ni1M EN ISO 17632-A : T 50 5 Z P M21 2 H5
Approvals	MoD : Q1N

Approvals are based on factory location. Please contact ESAB for more information.

Welding Current	DC+
Diffusible Hydrogen	< 5 ml/100g
Alloy Type	Low alloy steel (1% Ni)
Shielding Gas	M21 (EN ISO 14175)

Typical Tensile Properties			
Condition	Yield Strength	Tensile Strength	Elongation
M21 shielding gas			
As Welded	604 MPa	663 MPa	26 %

Typical Charpy V-Notch Properties		
Condition	Testing Temperature	Impact Value
M21 shielding gas		
As Welded	-50 °C	106 J

Typical Weld Metal Analysis %									
C	Mn	Si	S	P	Ni	Cr	Mo	V	Cu
M21 shielding gas									
0.05	1.45	0.41	0.011	0.008	1.00	0.02	0.01	0.02	0.01

Typical Weld Metal Analysis %	
Nb	
M21 shielding gas	
0.02	

Deposition Data				
Diameter	Current	Voltage	Wire Feed Speed	Deposition Rate
1.2 mm	100-300 A	21-32 V	3.2-14.5 m/min	1.3-5.8 kg/h

OK Tubrod 15.20

A basic cored wire for welding 1%Cr 0.5% Mo creep resisiting steels using M21 shielding gas.

Specifications

Classifications	SFA/AWS A5.29 : E81T5-B2M H4
Welding Current	DC-
Diffusible Hydrogen	< 4 ml/100g
Alloy Type	Creep resisiting low alloy steel (1% Cr, 0.5% Mo)
Shielding Gas	M21 (EN ISO 14175)

Typical Tensile Properties

Condition	Yield Strength	Tensile Strength	Elongation
M21 shielding gas			
PWHT 1 hour(s) 690 °C	570 MPa	670 MPa	22 %

Typical Weld Metal Analysis %

C	Mn	Si	Cr	Mo
M21 shielding gas				
0.05	1.02	0.53	1.35	0.60

Deposition Data

Diameter	Current	Voltage	Wire Feed Speed	Deposition Rate
1.2 mm	120-300 A	16-32 V	4.0-15.0 m/min	1.7-6.5 kg/h

OK Tubrod 15.22

A basic cored wire for welding 2.25%Cr 1% Mo creep resisting steels using M21 shielding gas.

Specifications

Classifications	SFA/AWS A5.29 : E90T5-B3
Welding Current	DC-
Diffusible Hydrogen	< 5 ml/100g
Alloy Type	Creep resisting low alloy steel (2% Cr, 1% Mo)
Shielding Gas	M21 (EN ISO 14175)

Typical Tensile Properties

Condition	Yield Strength	Tensile Strength	Elongation
AWS M21 shielding gas			
PWHT 1 hour(s) 675 °C	605 MPa	685 MPa	22 %

Typical Weld Metal Analysis %

C	Mn	Si	Cr	Mo
M21 shielding gas				
0.06	0.95	0.52	2.32	0.99

Deposition Data

Diameter	Current	Voltage	Wire Feed Speed	Deposition Rate
1.2 mm	120-300 A	16-32 V	4.0-15.0 m/min	1.7-6.5 kg/h

OK Tubrod 15.24S

A 1% Ni basic cored wire for submerged arc welding giving good toughness down to -50 °C.

Specifications	
Classifications	SFA/AWS A5.23 : F7P8-EC-G (10.61) SFA/AWS A5.23 : F8A6-EC-G (10.62) SFA/AWS A5.23 : F8A6-EC-G (10.71) EN ISO 14171-A : S 46 4 AB TZ (10.71) EN ISO 14171-A : S 46 5 FB T3Ni1 (10.62)
Approvals	ABS : 4YQ460M H5 (10.62) BV : 4Y46M H5 (10.62) CE : EN 13479 (10.62) CE : EN 13479 (10.71) DNV-GL : IV Y46M(H5) (10.62) UKCA : EN 13479 (10.71)

Approvals are based on factory location. Please contact ESAB for more information.

Diffusible Hydrogen	<5ml/100g
Alloy Type	Low alloy (1% Ni)

Typical Tensile Properties			
Condition	Yield Strength	Tensile Strength	Elongation
AWS OK Flux 10.62			
As Welded	510 MPa	610 MPa	29 %

Typical Charpy V-Notch Properties		
Condition	Testing Temperature	Impact Value
AWS OK Flux 10.62		
As Welded	-50 °C	106 J

Typical Weld Metal Analysis %			
C	Mn	Si	Ni
with OK Flux 10.71			
0.08	1.95	0.5	0.65
with OK Flux 10.61			
0.08	1.5	0.3	0.65
with OK Flux 10.62			
0.08	1.61	0.24	0.65

Deposition Data				
Diameter	Current	Voltage	Wire Feed Speed	Deposition Rate
2.4 mm	250-500 A	28-38 V	1.5-2.5 m/min	3.5-9.5 kg/h
3.0 mm	400-800 A	28-40 V	2.5-6.0 m/min	6.0-14.5 kg/h
4.0 mm	500-900 A	28-40 V	2.0-5.5 m/min	7.0-18.0 kg/h

OK Tubrod 15.27

A basic cored wire for welding steels with a minimum yield strength of 690 MPa for use with Ar/CO₂ shielding gas.

Specifications	
Classifications	SFA/AWS A5.36 : E110T5-M21A6-G EN ISO 18276-A : T 69 5 Mn2.5Ni B M21 3 H5
Welding Current	DC-
Diffusible Hydrogen	< 5 ml/100g
Alloy Type	Low alloy high strength steel (HY100)
Shielding Gas	M21 (EN ISO 14175)

Typical Tensile Properties			
Condition	Yield Strength	Tensile Strength	Elongation
M21 shielding gas			
As Welded	750 MPa	820 MPa	21 %

Typical Charpy V-Notch Properties		
Condition	Testing Temperature	Impact Value
M21 shielding gas		
As Welded	-40 °C	120 J
As Welded	-50 °C	80 J

Typical Weld Metal Analysis %			
C	Mn	Si	Ni
M21 shielding gas			
0.06	1.6	0.5	2.5

Deposition Data				
Diameter	Current	Voltage	Wire Feed Speed	Deposition Rate
1.2 mm	120-300 A	16-32 V	4.0-15.0 m/min	1.7-6.5 kg/h

OK Tubrod 15.27S

A basic cored wire designed for the submerged arc welding of steels with a minimum yield strength of 690 MPa.

Specifications	
Classifications	SFA/AWS A5.23 : F11A8-EC-G (OK Flux 10.62) EN ISO 26304-A : T 69 6 FB TZ H5 (OK Flux 10.62)
Approvals	ABS : 5YQ690M H5 CCS : 5Y69M CE : EN 13479 (10.62) CE : EN 13479 DNV-GL : V Y69M(H5) LR : 5Y69M H5 UKCA : EN 13479

Approvals are based on factory location. Please contact ESAB for more information.

Welding Current	DC+
Diffusible Hydrogen	< 5 ml/100g
Alloy Type	Low alloy high strength steel

Typical Tensile Properties			
Condition	Yield Strength	Tensile Strength	Elongation
OK Flux 10.62			
As Welded	747 MPa	812 MPa	23 %

Typical Charpy V-Notch Properties		
Condition	Testing Temperature	Impact Value
OK Flux 10.62		
As Welded	-40 °C	110 J
As Welded	-60 °C	80 J

Typical Weld Metal Analysis %				
C	Mn	Si	Ni	Mo
OK Flux 10.62				
0.07	1.90	0.40	2.44	0.32

Deposition Data				
Diameter	Current	Voltage	Wire Feed Speed	Deposition Rate
2.4 mm	250-500 A	28-38 V	1.5-2.5 m/min	3.5-9.5 kg/h
3.0 mm	300-700 A	28-38 V	2.5-5.5 m/min	6.0-12.5 kg/h
3.2 mm	350-750 A	28-38 V	2.5-5.0 m/min	5.5-13.5 kg/h
4.0 mm	450-900 A	28-40 V	2.0-5.5 m/min	7.0-18.0 kg/h

Pipeweld 71T-1

An all-positional rutile cored wire for pipe welding. The weld metal has a minimum yield strength of 420 MPa with CO₂ shielding gas and 460 MPa with Ar/CO₂ mixed gas.

Specifications	
Classifications	SFA/AWS A5.20 : E71T-1C H4 SFA/AWS A5.20 : E71T-1M H8 EN ISO 17632-A : T 42 3 P C1 1 H5 EN ISO 17632-A : T 46 4 P M21 1 H5
Approvals	ABS : 4YSA H10

Approvals are based on factory location. Please contact ESAB for more information.

Welding Current	DC+
Alloy Type	Non alloy
Shielding Gas	M21, C1 (EN ISO 14175)

Typical Tensile Properties			
Condition	Yield Strength	Tensile Strength	Elongation
M21 shielding gas			
As Welded	535 MPa	601 MPa	25 %
C1 shielding gas			
As Welded	495 MPa	585 MPa	25 %

Typical Charpy V-Notch Properties		
Condition	Testing Temperature	Impact Value
M21 shielding gas		
As Welded	-40 °C	70 J
C1 shielding gas		
As Welded	-30 °C	65 J

Typical Weld Metal Analysis %		
C	Mn	Si
M21 shielding gas		
0.059	1.33	0.63

Deposition Data				
Diameter	Current	Voltage	Wire Feed Speed	Deposition Rate
1.2 mm	150-350 A	23-35 V	5.8-20.7 m/min	2.1-7.5 kg/h

Pipeweld 91T-1

An all-positional rutile cored wire for pipe welding of steels with a minimum strength of 550 MPa, for use with M21 shielding gas.

Specifications	
Classifications	SFA/AWS A5.29 : E91T1-G EN ISO 18276-A : T 55 4 Z P M21 2 H5
Approvals	CE : EN 13479 UKCA : EN 13479

Approvals are based on factory location. Please contact ESAB for more information.

Welding Current	DC+
Alloy Type	Low alloy

Typical Tensile Properties			
Condition	Yield Strength	Tensile Strength	Elongation
As Welded	604 MPa	670 MPa	27 %

Typical Charpy V-Notch Properties		
Condition	Testing Temperature	Impact Value
As Welded	-40 °C	95 J

Typical Weld Metal Analysis %				
C	Mn	Si	Ni	Mo
0.05	1.25	0.37	0.93	0.12

Deposition Data				
Diameter	Current	Voltage	Wire Feed Speed	Deposition Rate
1.2 mm	100-300 A	21-32 V	3.2-14.5 m/min	1.3-5.8 kg/h

Pipeweld 101T-1

An all-positional rutile cored wire for pipe welding of steels with a minimum strength of 610 MPa, for use with M21 shielding gas.

Specifications

Classifications	SFA/AWS A5.29 : E101T1-G EN ISO 18276-A : T 62 4 Mn1Ni P M21 2 H5
Welding Current	DC+
Alloy Type	Low alloy

Typical Tensile Properties

Condition	Yield Strength	Tensile Strength	Elongation
M21 Shielding gas			
As Welded	654 MPa	709 MPa	25 %

Typical Charpy V-Notch Properties

Condition	Testing Temperature	Impact Value
M21 Shielding gas		
As Welded	-40 °C	70 J

Typical Weld Metal Analysis %

C	Mn	Si	Ni	Mo
M21 Shielding gas				
0.06	1.54	0.40	0.97	0.15

Deposition Data

Diameter	Current	Voltage	Wire Feed Speed	Deposition Rate
1.2 mm	100-300 A	21-32 V	3.2-14.5 m/min	1.3-5.8 kg/h

Pipeweld 111T-1

An all positionable rutile flux cored wire that is used with Ar-CO₂ shielding gas. This wire offers excellent weldability. Suitable for up to X100 strength pipe.

Specifications	
Classifications	SFA/AWS A5.29 : E111T1-K3MJ-H4 EN ISO 18276-A : T 69 4 2NiMo P M21 2 H5

Welding Current	DC+
Alloy Type	Low Alloy (Ni Mo)
Shielding Gas	M21 (EN ISO 14175)

Typical Tensile Properties			
Condition	Yield Strength	Tensile Strength	Elongation
M21 shielding gas			
As Welded	761 MPa	840 MPa	19 %

Typical Charpy V-Notch Properties		
Condition	Testing Temperature	Impact Value
M21 shielding gas		
As Welded	-40 °C	60 J

Typical Weld Metal Analysis %				
C	Mn	Si	Ni	Mo
0.055	1.21	0.39	2.3	0.4

Deposition Data				
Diameter	Current	Voltage	Wire Feed Speed	Deposition Rate
1.2 mm	150-350 A	21-32 V	5.6-19.8 m/min	2.1-7.5 kg/h

Coreshield 71T-8 OS

Coreshield 71T-8 OS is a self-shielded flux cored wire designed to weld critical structural applications such as TKY joints for offshore construction, pipe structures, bridges and storage tanks. It is designed to provide excellent low temperature impact toughness down to -40 degrees C, whilst maintaining great arc characteristics, high welder appeal and easy slag removal in all welding positions.

Specifications	
Classifications	SFA/AWS A5.29 : E71T8-Ni1 J H8 EN ISO 17632-A : T42 4 1Ni Y NO 1
Approvals	ABS : E71T8-Ni1 JH8 BV : SA4Y40 CE : EN 13479 CWB : E491T8-Ni1-JH8 (E71T8-Ni1-JH8) DNV : IV Y40MS UKCA : EN 13479

Approvals are based on factory location. Please contact ESAB for more information.

Welding Current	DC-
Diffusible Hydrogen	<8
Alloy Type	C-Mn-Ni-Al

Typical Tensile Properties			
Condition	Yield Strength	Tensile Strength	Elongation
AWS			
As Welded	429 MPa	521 MPa	28 %

Typical Charpy V-Notch Properties		
Condition	Testing Temperature	Impact Value
AWS		
As Welded	-40 °C	172 J

Typical Weld Metal Analysis %						
C	Mn	Si	S	P	Ni	Al
AWS DC-						
0.06	1.05	0.15	0.003	0.006	0.93	0.92

Deposition Data				
Diameter	Current	Voltage	Wire Feed Speed	Deposition Rate
2.0 mm	160-250 A	18-23 V	1.4-2.6 m/min	1.1-2.3 kg/h

OK Autrod 12.24

Mo-alloyed, copper-coated wire for Submerged Arc Welding. For creep resistant steels (0,5% Mo), structural steels, ship building steels, pressure vessel steels, pipeline steels up to X70, etc.

Specifications	
Classifications	SFA/AWS A5.23 : EA2 EN ISO 14171-A : S2Mo EN ISO 24598-A : S S Mo
Approvals	CE : EN 13479 DB : 52.039.06 UKCA : EN 13479 VdTÜV : 12103

Approvals are based on factory location. Please contact ESAB for more information.

Typical Wire Composition %			
C	Mn	Si	Mo
0.09	1.08	0.14	0.48

OK Autrod 12.34

Mo-alloyed, copper-coated wire for Submerged Arc and Electroslag Welding. For creep resistant steels (0,5% Mo), structural steels, ship building steels, pressure vessel steels, pipeline steels up to X80, high strength steels, etc.

Specifications	
Classifications	SFA/AWS A5.23 : EA4 EN ISO 14171-A : S3Mo EN ISO 24598-A : S S MnMo
Approvals	CE : EN 13479 UKCA : EN 13479 VdTÜV : 12103

Approvals are based on factory location. Please contact ESAB for more information.

Typical Wire Composition %			
C	Mn	Si	Mo
0.13	1.51	0.16	0.48

OK Autrod 13.10 SC

Cr-, Mo-alloyed, copper-coated wire for Submerged Arc Welding. Low level of impurities. X-bar (Bruscato-) in the wire max. 10. With OK Flux 10.63 for toughness requirements also after Step-Cooling; clean weld metal with X-bar max. 12. Mainly for creep resistant steels (1,25% Cr, 0,5% Mo).

Specifications	
Classifications	SFA/AWS A5.23 : EB2R EN ISO 24598-A : S S CrMo1
Approvals	CE : EN 13479 DB : 52.039.09 UKCA : EN 13479 VdTÜV : 12104

Approvals are based on factory location. Please contact ESAB for more information.

Typical Wire Composition %				
C	Mn	Si	Cr	Mo
0.10	0.83	0.12	1.21	0.49



OK Autrod 13.21

Ni-alloyed, copper-coated wire for Submerged Arc Welding. For structural steels, ship building steels, pressure vessel steels, fine grained steels, etc. at lower temperatures.

Specifications	
Classifications	SFA/AWS A5.23 : ENi1 EN ISO 14171-A : S2Ni1
Approvals	VdTÜV : 12103

Approvals are based on factory location. Please contact ESAB for more information.

Typical Wire Composition %			
C	Mn	Si	Ni
0.11	0.98	0.15	0.90

OK Autrod 13.24

Ni-, Mo-alloyed, copper-coated wire for Submerged Arc Welding. With OK Flux 10.62 excellent toughness values; CTOD tested. For low temperature steels and fine grained steels in ship building and Off-Shore industries, etc.

Specifications	
Classifications	SFA/AWS A5.23 : ENi6 EN ISO 14171-A : S3Ni1Mo0,2
Approvals	CE : EN 13479 UKCA : EN 13479 VdTÜV : 12103

Approvals are based on factory location. Please contact ESAB for more information.

Typical Wire Composition %					
C	Mn	Si	Ni	Mo	
0.12	1.52	0.23	0.88	0.19	

OK Autrod 13.27

Ni-alloyed, copper-coated wire for Submerged Arc Welding. With OK Flux 10.62 excellent toughness values; CTOD tested. For low temperature steels and fine grained steels in ship building, Off-Shore, pressure vessel industries, etc.

Specifications	
Classifications	SFA/AWS A5.23 : ENi2 EN ISO 14171-A : S2Ni2
Approvals	CE : EN 13479 DB : 52.039.08 UKCA : EN 13479 VdTÜV : 12103

Approvals are based on factory location. Please contact ESAB for more information.

Typical Wire Composition %			
C	Mn	Si	Ni
0.10	1.02	0.14	2.19

OK Autrod 13.33

Cr-, Mo-alloyed, copper-coated wire for Submerged Arc Welding. Mainly for creep resistant steels (5% Cr, 0.5% Mo).

Specifications	
Classifications	SFA/AWS A5.23 : EB6 EN ISO 24598-A : S S CrMo5
Approvals	VdTÜV : 12104

Approvals are based on factory location. Please contact ESAB for more information.

Alloy Type	Low alloyed (6 % Cr, 0.5 % Mo)
-------------------	--------------------------------

Typical Wire Composition %				
C	Mn	Si	Cr	Mo
0.09	0.51	0.42	5.73	0.53

OK Autrod 13.35

Cr-, Mo-alloyed, non copper-coated wire for Submerged Arc Welding. Mainly for creep resistant steels (9% Cr, 1% Mo V Nb).

Specifications	
Classifications	SFA/AWS A5.23 : EB91 EN ISO 24598-A : S S CrMo91
Approvals	VdTÜV : 12104

Approvals are based on factory location. Please contact ESAB for more information.

Typical Wire Composition %								
C	Mn	Si	Ni	Cr	Mo	V	N	Nb
0.10	0.52	0.22	0.67	8.82	0.92	0.20	0.05	0.07

OK Autrod 13.36

Ni-, Cu-, Cr-alloyed, copper-coated wire for Submerged Arc Welding. For weather resistant steels such as COR-TEN, Patinax, etc.

Specifications	
Classifications	SFA/AWS A5.23 : EG EN ISO 14171-A : S2Ni1Cu
Approvals	CE : EN 13479 DB : 52.039.04 UKCA : EN 13479 VdTUV : 12103

Approvals are based on factory location. Please contact ESAB for more information.

Typical Wire Composition %					
C	Mn	Si	Ni	Cr	Cu
0.10	0.95	0.29	0.78	0.29	0.48

OK Autrod 13.40

Ni-, Mo-alloyed, copper-coated wire for Submerged Arc Welding. Preferably in combination with OK Flux 10.62. For high strength steels with minimum yield strengths up to 550 MPa (in AC current up to 620 MPa), low temperature steels, fine grained steels, etc.

Specifications	
Classifications	SFA/AWS A5.23 : EF3 EN ISO 14171-A : S3Ni1Mo EN ISO 26304-A : S3Ni1Mo EN ISO 26304-B : (SUN2M2)
Approvals	CE : EN 13479 UKCA : EN 13479 VdTÜV : 12103

Approvals are based on factory location. Please contact ESAB for more information.

Typical Wire Composition %				
C	Mn	Si	Ni	Mo
0.11	1.63	0.16	0.86	0.51

OK Autrod 13.43

Ni-, Cr-, Mo-alloyed, copper-coated wire for Submerged Arc Welding. Preferably in combination with OK Flux 10.62. For high strength steels with minimum yield strengths up to 690 MPa, low temperature steels, fine grained steels, etc.

Specifications	
Classifications	SFA/AWS A5.23 : EG EN ISO 26304-A : S3Ni2.5CrMo EN ISO 26304-B : (SUN4C1M3)
Approvals	CE : EN 13479 UKCA : EN 13479 VdTÜV : 12104

Approvals are based on factory location. Please contact ESAB for more information.

Typical Wire Composition %					
C	Mn	Si	Ni	Cr	Mo
0.12	1.55	0.19	2.29	0.67	0.47

OK Autrod 13.49

Ni-alloyed, copper-coated wire for Submerged Arc Welding. Mainly for low temperature steels down to temperatures of -101°C.

Specifications

Classifications	SFA/AWS A5.23 : ENi3 EN ISO 14171-A : S2Ni3
Approvals	VdTÜV : 12103

Approvals are based on factory location. Please contact ESAB for more information.

Typical Wire Composition %

C	Mn	Si	Ni
0.09	0.95	0.15	3.28

OK Autrod 13.62

Low-alloyed and Ti-B micro-alloyed, however Mo-free copper-coated solid wire for Submerged Arc Welding. Especially for high dilution welds where low temperature impact toughness properties are required. Without Mo for relatively low hardness values in weld joints. For fine grained steels, pipeline steels, ship building steels, etc.

Specifications

Classifications

SFA/AWS A5.23 : EG
EN ISO 14171-A : SZ3TiB

Typical Wire Composition %

C	Mn	Si	Mo	Ti	B
0.07	1.55	0.28	0.01	0.14	0.013

OK Autrod 13.64

Low-alloyed and Ti-B micro-alloyed, copper-coated solid wire for Submerged Arc Welding. Especially for high dilution welds where low temperature impact toughness properties are required. For fine grained steels, pipeline steels, ship building steels, etc.

Specifications

Classifications	SFA/AWS A5.23 : EA2TiB EN ISO 14171-A : S2MoTiB
Approvals	VdTÜV : 12103

Approvals are based on factory location. Please contact ESAB for more information.

Typical Wire Composition %

C	Mn	Si	Mo	Ti	B
0.07	1.22	0.28	0.49	0.14	0.013

OK Tubrod 15.24S

A 1% Ni basic cored wire for submerged arc welding giving good toughness down to -50 °C.

Specifications	
Classifications	SFA/AWS A5.23 : F7P8-EC-G (10.61) SFA/AWS A5.23 : F8A6-EC-G (10.62) SFA/AWS A5.23 : F8A6-EC-G (10.71) EN ISO 14171-A : S 46 4 AB TZ (10.71) EN ISO 14171-A : S 46 5 FB T3Ni1 (10.62)
Approvals	ABS : 4YQ460M H5 (10.62) BV : 4Y46M H5 (10.62) CE : EN 13479 (10.62) CE : EN 13479 (10.71) DNV-GL : IV Y46M(H5) (10.62) UKCA : EN 13479 (10.71)

Approvals are based on factory location. Please contact ESAB for more information.

Diffusible Hydrogen	<5ml/100g
Alloy Type	Low alloy (1% Ni)

Typical Tensile Properties			
Condition	Yield Strength	Tensile Strength	Elongation
AWS OK Flux 10.62			
As Welded	510 MPa	610 MPa	29 %

Typical Charpy V-Notch Properties		
Condition	Testing Temperature	Impact Value
AWS OK Flux 10.62		
As Welded	-50 °C	106 J

Typical Weld Metal Analysis %			
C	Mn	Si	Ni
with OK Flux 10.71			
0.08	1.95	0.5	0.65
with OK Flux 10.61			
0.08	1.5	0.3	0.65
with OK Flux 10.62			
0.08	1.61	0.24	0.65

Deposition Data				
Diameter	Current	Voltage	Wire Feed Speed	Deposition Rate
2.4 mm	250-500 A	28-38 V	1.5-2.5 m/min	3.5-9.5 kg/h
3.0 mm	400-800 A	28-40 V	2.5-6.0 m/min	6.0-14.5 kg/h
4.0 mm	500-900 A	28-40 V	2.0-5.5 m/min	7.0-18.0 kg/h

OK Tubrod 15.27S

A basic cored wire designed for the submerged arc welding of steels with a minimum yield strength of 690 MPa.

Specifications	
Classifications	SFA/AWS A5.23 : F11A8-EC-G (OK Flux 10.62) EN ISO 26304-A : T 69 6 FB TZ H5 (OK Flux 10.62)
Approvals	ABS : 5YQ690M H5 CCS : 5Y69M CE : EN 13479 (10.62) CE : EN 13479 DNV-GL : V Y69M(H5) LR : 5Y69M H5 UKCA : EN 13479

Approvals are based on factory location. Please contact ESAB for more information.

Welding Current	DC+
Diffusible Hydrogen	< 5 ml/100g
Alloy Type	Low alloy high strength steel

Typical Tensile Properties			
Condition	Yield Strength	Tensile Strength	Elongation
OK Flux 10.62			
As Welded	747 MPa	812 MPa	23 %

Typical Charpy V-Notch Properties		
Condition	Testing Temperature	Impact Value
OK Flux 10.62		
As Welded	-40 °C	110 J
As Welded	-60 °C	80 J

Typical Weld Metal Analysis %				
C	Mn	Si	Ni	Mo
OK Flux 10.62				
0.07	1.90	0.40	2.44	0.32

Deposition Data				
Diameter	Current	Voltage	Wire Feed Speed	Deposition Rate
2.4 mm	250-500 A	28-38 V	1.5-2.5 m/min	3.5-9.5 kg/h
3.0 mm	300-700 A	28-38 V	2.5-5.5 m/min	6.0-12.5 kg/h
3.2 mm	350-750 A	28-38 V	2.5-5.0 m/min	5.5-13.5 kg/h
4.0 mm	450-900 A	28-40 V	2.0-5.5 m/min	7.0-18.0 kg/h

OK Autrod B2 SC

Cr-, Mo-alloyed, copper-coated wire for Submerged Arc Welding. Very low level of impurities. X-bar (Bruscati-) max. 7. With OK Flux 10.66 for highest toughness requirements also after Step-Cooling; very clean weld metal with X-bar max. 10. Mainly for creep resistant steels (1,25% Cr, 0,5% Mo).

Specifications	
Classifications	SFA/AWS A5.23 : EB2R EN ISO 24598-A : S S CrMo1
Approvals	CE : EN 13479 UKCA : EN 13479

Approvals are based on factory location. Please contact ESAB for more information.

Typical Wire Composition %									
C	Mn	Si	S	P	Ni	Cr	Mo	V	Al
0.10	0.65	0.12	0.003	0.004	0.06	1.20	0.50	0.005	0.005

Typical Wire Composition %									
Cu	Nb	Ti	Sb	As	B	Sn	Mn+Si	Nb+Ti+V	P+Sn
0.08	0.004	0.002	0.002	0.003	0.0005	0.002	0.77	0.011	0.006

Typical Wire Composition %	
J-Factor	X-bar
50	5

OK Autrod B3 SC

Cr-, Mo-alloyed, copper-coated wire for Submerged Arc Welding. Very low level of impurities. X-bar (Bruscatto-) max. 7. With OK Flux 10.65 for highest toughness requirements also after Step-Cooling; very clean weld metal with X-bar max. 10. Mainly for creep resistant steels (2,25% Cr, 1% Mo).

Specifications

Classifications	SFA/AWS A5.23 : EB3R EN ISO 24598-A : S S CrMo2
Approvals	CE : EN 13479 UKCA : EN 13479

Approvals are based on factory location. Please contact ESAB for more information.

Typical Wire Composition %

C	Mn	Si	S	P	Ni	Cr	Mo	V	Al
0.11	0.65	0.10	0.003	0.003	0.08	2.50	1.00	0.006	0.005

Typical Wire Composition %

Cu	Nb	Ti	Sb	As	B	Sn	Mn+Si	Nb+Ti+V	P+Sn
0.08	0.006	0.002	0.002	0.003	0.0005	0.003	0.75	0.014	0.006

Typical Wire Composition %

J-Factor	X-bar
50	5



**Mild Steel/Low Alloy
Subarc (SAW) Fluxes**

MILD STEEL/LOW ALLOY SUBARC (SAW) FLUXES	3-3
OK Flux 10.61	3-3
OK Flux 10.62	3-6
OK Flux 10.63	3-12
OK Flux 10.64	3-14
OK Flux 10.65	3-15
OK Flux 10.66	3-17
OK Flux 10.69	3-19
OK Flux 10.70	3-20
OK Flux 10.71	3-22
OK Flux 10.72	3-27
OK Flux 10.74	3-30
OK Flux 10.77	3-33
OK Flux 10.78	3-36
OK Flux 10.79	3-37
OK Flux 10.81	3-38
OK Flux 10.83	3-41

OK Flux 10.61

Agglomerated fluoride-basic flux for Submerged Arc Welding. Designed for single-wire butt welding when high impact properties at low temperatures are required. For general construction, pressure vessels, power generation, transport industries, etc. Suitable for DC only. Single layer and multi layer welding of unlimited plate thickness.

Specifications	
Classifications	EN ISO 14174 : S A FB 1 65 DC
Approvals	CE : EN 13479 DB : 51.039.03 UKCA : EN 13479

Approvals are based on factory location. Please contact ESAB for more information.

Slag Type	Fluoride-basic
Alloy Transfer	Slightly Silicon and no Manganese alloying
Density	nom: 1.1 kg/dm ³
Basicity Index	nom: 2.6

Flux Consumption	
Volts	kg Flux / kg Wire DC+
26 V	0.7 kg
30 V	1.0 kg
34 V	1.3 kg
38 V	1.6 kg

Conditions : Dimension Ø 4.0 mm , Amps 580 A , Travel Speed 55 cm/min

Classifications	Wire	Weld Metal		
		EN - As Welded	AWS - As Welded	AWS - PWHT
OK Autrod 12.10	A5.17:EL12 14171-A:S1	14171-A: S 35 2 FB S1	-	-
OK Autrod 12.22	A5.17:EM12K 14171-A:S2Si	14171-A: S 38 4 FB S2Si	A5.17: F7A8-EM12K	A5.17: F6P8-EM12K
OK Autrod 12.24	A5.23:EA2 14171-A:S2Mo 24598-A:S S Mo	14171-A: S 42 2 FB S2Mo	A5.23: F7A4-EA2-A2	A5.23: F7P2-EA2-A2
OK Autrod 12.32	A5.17:EH12K 14171-A:S3Si	14171-A: S 42 5 FB S3Si	A5.17: F7A6-EH12K	A5.17: F7P8-EH12K
OK Autrod 12.40	A5.17:EH14 14171-A:S4	14171-A: S 46 3 FB S4	A5.17: F7A6-EH14	A5.17: F7P6-EH14
OK Autrod 13.10 SC	A5.23:EB2R 24598-A:S S CrMo1	-	-	A5.23: F8P2-EB2R-B2
OK Autrod 13.20 SC	A5.23:EB3R 24598-A:S S CrMo2	-	-	A5.23: F8P0-EB3R-B3
OK Autrod 13.36	A5.23:EG 14171-A:S2Ni1Cu	14171-A: S 46 3 FB S2Ni1Cu	-	-

Approvals				
Wire	CE	DB	VdTÜV	
OK Autrod 12.10	•	•	•	
OK Autrod 12.22	•	-	-	
OK Autrod 12.24	•	-	•	
OK Autrod 12.32	•	-	-	
OK Autrod 13.10 SC	•	•	•	

OK Flux 10.61

Approvals

Wire	CE	DB	VdTÜV
OK Autrod 13.20 SC	-	-	•
OK Autrod 13.36	•	•	-

Typical Weld Metal Analysis %

C	Mn	Si	S	P	Ni	Cr	Mo	Cu
OK Autrod 12.10 DC+, 580A, 29V								
0.07	0.5	0.15	-	-	-	-	-	-
OK Autrod 12.22 DC+, 580A, 29V								
0.08	1.0	0.35	-	-	-	-	-	-
OK Autrod 12.24 DC+, 580A, 29V								
0.06	1.0	0.25	-	-	-	-	0.5	-
OK Autrod 12.32 DC+, 580A, 29V								
0.09	1.4	0.3	-	-	-	-	-	-
OK Autrod 12.40 DC+, 580A, 29V								
0.08	1.8	0.15	-	-	-	-	-	-
OK Autrod 13.10 SC DC+, 580A, 29V								
0.08	0.7	0.30	-	-	-	1.1	0.5	-
OK Autrod 13.20 SC DC+, 580A, 29V								
0.08	0.8	0.3	-	-	-	2.1	1.0	-
OK Autrod 13.36 DC+, 580A, 29V, 55cm/min								
0.07	1.0	0.5	0.010	0.015	0.7	0.2	-	0.4

Typical Mechanical Properties

Wire	Condition	Yield Strength	Tensile Strength	Elongation	Charpy V-Notch
OK Autrod 12.10	As Welded EN DC+	375 MPa	445 MPa	30 %	180 J @ 20 °C 130 J @ -10 °C 100 J @ -20 °C
OK Autrod 12.22	Stress Relieved AWS DC+ (1.0 hour(s))	410 MPa	500 MPa	30 %	110 J @ -20 °C 95 J @ -30 °C 80 J @ -40 °C 35 J @ -62 °C
OK Autrod 12.22	As Welded AWS DC+	440 MPa	520 MPa	30 %	120 J @ -20 °C 85 J @ -30 °C 75 J @ -40 °C 35 J @ -62 °C
OK Autrod 12.22	As Welded EN DC+	430 MPa	500 MPa	30 %	130 J @ -20 °C 80 J @ -30 °C 70 J @ -40 °C 35 J @ -62 °C
OK Autrod 12.24	Stress Relieved AWS DC+ (1.0 hour(s))	440 MPa	530 MPa	26 %	85 J @ 20 °C 70 J @ 0 °C 45 J @ -20 °C 40 J @ -29 °C
OK Autrod 12.24	As Welded AWS DC+	480 MPa	570 MPa	26 %	130 J @ 20 °C 120 J @ 0 °C 80 J @ -20 °C 45 J @ -29 °C 35 J @ -40 °C

OK Flux 10.61

Typical Mechanical Properties					
Wire	Condition	Yield Strength	Tensile Strength	Elongation	Charpy V-Notch
OK Autrod 12.24	As Welded EN DC+	480 MPa	560 MPa	26 %	130 J @ 20 °C 120 J @ 0 °C 80 J @ -20 °C 45 J @ -29 °C 35 J @ -40 °C
OK Autrod 12.32	Stress Relieved AWS DC+ (1.0 hour(s))	420 MPa	530 MPa	27 %	180 J @ -20 °C 150 J @ -40 °C 100 J @ -51 °C 80 J @ -62 °C
OK Autrod 12.32	As Welded EN DC+	450 MPa	550 MPa	26 %	110 J @ -20 °C 90 J @ -40 °C 55 J @ -50 °C 40 J @ -62 °C
OK Autrod 12.32	As Welded AWS DC+	450 MPa	560 MPa	27 %	120 J @ -20 °C 100 J @ -40 °C 55 J @ -51 °C 35 J @ -62 °C
OK Autrod 12.40	Stress Relieved AWS DC+ (1.0 hour(s))	440 MPa	530 MPa	26 %	65 J @ -30 °C 45 J @ -40 °C 40 J @ -51 °C
OK Autrod 12.40	As Welded AWS DC+	490 MPa	580 MPa	26 %	60 J @ -30 °C 40 J @ -40 °C 35 J @ -51 °C
OK Autrod 12.40	As Welded EN DC+	490 MPa	570 MPa	25 %	60 J @ -30 °C 40 J @ -40 °C 35 J @ -51 °C
OK Autrod 13.10 SC	Stress Relieved EN DC+ (1 hour(s))	560 MPa	650 MPa	25 %	180 J @ 20 °C 110 J @ -20 °C 45 J @ -40 °C
OK Autrod 13.10 SC	Stress Relieved AWS DC+ (1.0 hour(s))	550 MPa	620 MPa	26 %	100 J @ -18 °C 70 J @ -29 °C
OK Autrod 13.10 SC	Stress Relieved EN DC+ (15.0 hour(s))	300 MPa	460 MPa	26 %	130 J @ 20 °C
OK Autrod 13.20 SC	Stress Relieved AWS DC+ (1.0 hour(s))	540 MPa	630 MPa	25 %	80 J @ -18 °C 30 J @ -29 °C
OK Autrod 13.20 SC	Stress Relieved EN DC+ (1.0 hour(s))	490 MPa	600 MPa	23 %	140 J @ 20 °C
OK Autrod 13.36	As Welded 580A, 29V, 55cm/min DC+	545 MPa	640 MPa	25 %	70 J @ -20 °C 55 J @ -30 °C 40 J @ -40 °C 35 J @ -50 °C

OK Flux 10.62

Agglomerated fluoride-basic flux for Submerged Arc Welding. Primarily for multi-run welding. For highest demands on impact properties, low temperature toughness, strength and CTOD-values. Especially suitable for narrow gap welding due to good slag detachability and smooth side-wall blending. The Advanced Slag Release version improves weldability with excellent slag detachability, even better side wall wetting and stronger grains which improve weld quality due to flux grain size consistency also after multiple recycling cycles. All other attributes unchanged. For Offshore constructions, pressure vessels, power generation, shipbuilding, pipe mills, civil constructions, transport industries, etc. Produces weld metals with hydrogen contents maximum 5 ml/100 g, in BlockPac (moisture protection) maximum 4 ml/100g. Operates optimally at the lower end of the voltage range. Designed for single and multi wire procedures, for butt and fillet welds. Works equally well on DC and AC current. Single layer and multi layer welding of unlimited plate thickness.

Specifications	
Classifications	EN ISO 14174 : S A FB 1 55 AC H5 EN ISO 14174 : S A FB 1 55 AC H4 only BlockPac/moisture-protection
Approvals	CE : EN 13479 DB : 51.039.07 UKCA : EN 13479

Approvals are based on factory location. Please contact ESAB for more information.

Diffusible Hydrogen	max 5 ml/100g weld metal (Redried flux); max 4 ml/100g in BlockPac (moisture protection)
Slag Type	Fluoride-basic
Alloy Transfer	No Silicon or Manganese alloying
Density	nom: 1.1 kg/dm ³
Basicity Index	nom: 3.2

Flux Consumption		
Volts	kg Flux / kg Wire DC+	kg Flux / kg Wire AC
26 V	0.7 kg	0.6 kg
30 V	1.0 kg	0.9 kg
34 V	1.3 kg	1.2 kg
38 V	1.6 kg	1.4 kg

Conditions : Dimension Ø 4.0 mm , Amps 580 A , Travel Speed 55 cm/min

Classifications	Wire	Weld Metal		
Wire	SFA/AWS - EN ISO	EN - As Welded	AWS - As Welded	AWS - PWHT
OK Autrod 12.22	A5.17:EM12K 14171-A:S2Si	14171-A: S 38 5 FB S2Si	A5.17: F7A8-EM12K	A5.17: F6P8-EM12K
OK Autrod 12.24	A5.23:EA2 14171-A:S2Mo; 24598-A:S S Mo	14171-A: S 46 4 FB S2Mo	A5.23: F8A6-EA2-A2	A5.23: F8P6-EA2-A2
OK Autrod 12.32	A5.17:EH12K 14171-A:S3Si	14171-A: S 46 6 FB S3Si	A5.17: F7A8-EH12K	A5.17: F7P8-EH12K
OK Autrod 12.34	A5.23:EA4 14171-A:S3Mo; 24598-A:S S MnMo	14171-A: S 50 4 FB S3Mo	A5.23: F8A6-EA4-A4	A5.23: F8P6-EA4-A4
OK Autrod 12.40	A5.17:EH14 14171-A:S4	14171-A: S 50 4 FB S4	A5.17: F7A6-EH14	A5.17: F7P6-EH14
OK Autrod 13.10 SC	A5.23:EB2R 24598-A:S S CrMo1	-	-	A5.23: F8P2-EB2R-B2
OK Autrod 13.20 SC	A5.23:EB3R 24598-A:S S CrMo2	-	-	A5.23: F8P2-EB3R-B3
OK Autrod 13.21	A5.23:ENi1 14171-A:S2Ni1	14171-A: S 42 4 FB S2Ni1	A5.23: F7A6-ENi1-Ni1	A5.23: F7P8-ENi1-Ni1
OK Autrod 13.24	A5.23:ENi6 14171-A:S3Ni1Mo0,2	14171-A: S 50 6 FB S3Ni1Mo0.2	A5.23: F8A10-ENi6-Ni6	A5.23: F8P8-ENi6-Ni6

OK Flux 10.62

Classifications	Wire	Weld Metal		
Wire	SFA/AWS - EN ISO	EN - As Welded	AWS - As Welded	AWS - PWHT
OK Autrod 13.27	A5.23:ENi2 14171-A:S2Ni2	14171-A: S 46 7 FB S2Ni2	A5.23: F7A10-ENi2-Ni2	A5.23: F7P10-ENi2-Ni2
OK Autrod 13.36	A5.23:EG 14171-A:S2Ni1Cu	14171-A: S 46 5 FB S2Ni1Cu	A5.23: F8A6-EG-G	-
OK Autrod 13.40	A5.23:EF3 14171-A:S3Ni1Mo; 26304-A:S3Ni1Mo; 26304-B:(SUN2M2)	26304-A: S 55 6 FB S3Ni1Mo	A5.23: F9A8-EF3-F3	A5.23: F9P8-EF3-F3
OK Autrod 13.43	A5.23:EG 26304-A:S3Ni2,5CrMo; 26304-B:(SUN4C1M3)	26304-A: S 69 6 FB S3Ni2, 5CrMo	A5.23: F11A8-EG-G	A5.23: F11P8-EG-G
OK Autrod 13.49	A5.23:ENi3 14171-A:S2Ni3	14171-A: S 46 8 FB S2Ni3	A5.23: F8A15-ENi3-Ni3	A5.23: F8P15-ENi3-Ni3

Approvals

Wire	ABS	BV	CE	DB	DNV	DNV-GL	GL	LR	RINA	RS	VdTUV
OK Autrod 12.22	•	•	•	•	•	-	•	•	-	-	•
OK Autrod 12.24	-	-	•	-	-	-	-	-	-	-	•
OK Autrod 12.32	•	•	•	•	•	-	•	•	•	•	•
OK Autrod 12.34	•	•	•	-	-	•	-	•	-	•	-
OK Autrod 12.40	-	-	-	-	-	•	-	-	-	-	-
OK Autrod 13.10 SC	-	-	•	•	-	-	-	-	-	-	-
OK Autrod 13.20 SC	-	-	•	-	-	-	-	-	-	-	•
OK Autrod 13.24	•	•	•	-	•	-	•	•	-	-	-
OK Autrod 13.27	•	•	•	•	•	-	•	•	•	•	•
OK Autrod 13.36	-	-	•	-	-	-	-	-	-	-	-
OK Autrod 13.40	•	•	•	-	•	-	-	•	-	-	•
OK Autrod 13.43	•	•	•	-	•	-	•	•	-	-	-
OK Tubrod 15.27S	•	-	•	-	•	-	•	•	-	-	-

Typical Weld Metal Analysis %

C	Mn	Si	Ni	Cr	Mo	Cu
OK Autrod 12.22 AC, 580 A, 29 V						
0.10	0.95	0.27	-	-	-	-
OK Autrod 12.22 DC+, 580 A, 29 V						
0.07	1.0	0.30	-	-	-	-
OK Autrod 12.24 DC+, 580A, 29V						
0.07	1.0	0.22	-	-	0.5	-
OK Autrod 12.32 AC, 580A, 29V						
0.11	1.5	0.3	-	-	-	-
OK Autrod 12.32 DC+, 580A, 29V						
0.10	1.6	0.35	-	-	-	-
OK Autrod 12.34 AC, 580A, 29V						
0.13	1.4	0.18	-	-	0.5	-
OK Autrod 12.34 DC+, 580A, 29V						
0.10	1.45	0.21	-	-	0.5	-
OK Autrod 12.40 AC, 580A, 29V						
0.12	1.85	0.10	-	-	-	-

OK Flux 10.62

Typical Weld Metal Analysis %

C	Mn	Si	Ni	Cr	Mo	Cu
OK Autrod 12.40 DC+, 580A, 29V						
0.08	1.9	0.12	-	-	-	-
OK Autrod 13.10 SC AC, 580A, 29V						
0.10	0.7	0.20	-	1.1	0.5	-
OK Autrod 13.10 SC DC+, 580A, 29V						
0.08	0.7	0.22	-	1.1	0.5	-
OK Autrod 13.20 SC AC, 580A, 29V						
0.09	0.60	0.20	-	2.2	1.0	-
OK Autrod 13.20 SC DC+, 580A, 29V						
0.08	0.60	0.20	-	2.2	0.95	-
OK Autrod 13.21 AC, 580A, 29V						
0.08	0.95	0.22	0.9	-	-	-
OK Autrod 13.21 DC+, 580A, 29V						
0.06	1.0	0.25	0.9	-	-	-
OK Autrod 13.24 AC, 580A, 29V						
0.10	1.3	0.25	0.9	-	0.2	-
OK Autrod 13.24 DC+, 580A, 29V						
0.08	1.4	0.30	0.9	-	0.2	-
OK Autrod 13.27 AC, 580A, 29V						
0.08	0.95	0.22	2.1	-	-	-
OK Autrod 13.27 DC+, 580A, 29V						
0.06	1.0	0.25	2.1	-	-	-
OK Autrod 13.36 AC, 580A, 29V						
0.10	0.9	0.3	0.7	3	-	0.4
OK Autrod 13.36 DC+, 525A, 29V						
0.08	1.0	0.3	0.7	0.3	-	0.4
OK Autrod 13.40 AC, 580A, 29V						
0.10	1.45	0.23	0.9	-	0.5	-
OK Autrod 13.40 DC+, 580A, 29V						
0.07	1.50	0.26	0.9	-	0.5	-
OK Autrod 13.43 AC, 580A, 29V						
0.12	1.45	0.22	2.2	0.6	0.5	-
OK Autrod 13.43 DC+, 580A, 29V						
0.11	1.5	0.25	2.2	0.6	0.5	-
OK Autrod 13.49 AC, 580A, 29V						
0.08	0.95	0.20	3.1	-	-	-
OK Autrod 13.49 DC+, 580A, 29V						
0.06	1.0	0.25	3.1	-	-	-

Typical Mechanical Properties

Wire	Condition	Yield Strength	Tensile Strength	Elongation	Charpy V-Notch
OK Autrod 12.22	As Welded EN AC	440 MPa	510 MPa	29 %	180 J @ 0 °C 170 J @ -20 °C 90 J @ -40 °C 80 J @ -50 °C

OK Flux 10.62

Typical Mechanical Properties						
Wire	Condition	Yield Strength	Tensile Strength	Elongation	Charpy V-Notch	
OK Autrod 12.22	As Welded AWS DC+	410 MPa	500 MPa	33 %	170 J @ 0 °C 160 J @ -20 °C 90 J @ -40 °C 70 J @ -50 °C 35 J @ -62 °C	
OK Autrod 12.22	Stress Relieved AWS DC+ (1.0 hour(s))	360 MPa	480 MPa	34 %	190 J @ 0 °C 170 J @ -20 °C 130 J @ -40 °C 75 J @ -50 °C 35 J @ -62 °C	
OK Autrod 12.24	Stress Relieved AWS DC+ (1.0 hour(s))	510 MPa	580 MPa	30 %	140 J @ 20 °C 100 J @ 0 °C 75 J @ -20 °C 55 J @ -40 °C 40 J @ -51 °C	
OK Autrod 12.24	As Welded EN AC	520 MPa	600 MPa	24 %	150 J @ 20 °C 125 J @ 0 °C 100 J @ -20 °C 55 J @ -40 °C 40 J @ -51 °C	
OK Autrod 12.24	As Welded AWS DC+	500 MPa	580 MPa	25 %	140 J @ 20 °C 115 J @ 0 °C 80 J @ -20 °C 60 J @ -40 °C 45 J @ -51 °C	
OK Autrod 12.32	Stress Relieved AWS DC+ (1.0 hour(s))	410 MPa	510 MPa	28 %	175 J @ 20 °C 165 J @ 0 °C 140 J @ -30 °C 110 J @ -40 °C 60 J @ -62 °C	
OK Autrod 12.32	As Welded EN AC	520 MPa	600 MPa	26 %	175 J @ 20 °C 170 J @ 0 °C 110 J @ -30 °C 90 J @ -40 °C 60 J @ -60 °C	
OK Autrod 12.32	As Welded AWS DC+	475 MPa	560 MPa	28 %	175 J @ 20 °C 150 J @ 0 °C 130 J @ -30 °C 110 J @ -40 °C 70 J @ -62 °C	
OK Autrod 12.34	Stress Relieved AWS DC+ (1.0 hour(s))	540 MPa	620 MPa	25 %	165 J @ 20 °C 150 J @ 0 °C 120 J @ -20 °C 70 J @ -40 °C 40 J @ -51 °C	
OK Autrod 12.34	As Welded EN AC	560 MPa	630 MPa	25 %	160 J @ 20 °C 150 J @ 0 °C 130 J @ -20 °C 100 J @ -40 °C 55 J @ -51 °C	
OK Autrod 12.34	As Welded AWS DC+	540 MPa	620 MPa	24 %	170 J @ 20 °C 160 J @ 0 °C 140 J @ -20 °C 115 J @ -40 °C 45 J @ -51 °C	

OK Flux 10.62

Typical Mechanical Properties

Wire	Condition	Yield Strength	Tensile Strength	Elongation	Charpy V-Notch
OK Autrod 12.40	Stress Relieved AWS DC+ (1.0 hour(s))	460 MPa	560 MPa	26 %	140 J @ 20 °C 110 J @ 0 °C 70 J @ -20 °C 45 J @ -40 °C 35 J @ -51 °C
OK Autrod 12.40	As Welded AWS DC+	530 MPa	620 MPa	26 %	140 J @ 20 °C 110 J @ 0 °C 80 J @ -20 °C 50 J @ -40 °C 40 J @ -51 °C
OK Autrod 12.40	As Welded EN AC	550 MPa	630 MPa	22 %	150 J @ 20 °C 105 J @ 0 °C 70 J @ -20 °C 55 J @ -40 °C 40 J @ -51 °C
OK Autrod 13.10 SC	Stress Relieved EN DC+ (1.0 hour(s))	510 MPa	605 MPa	25 %	200 J @ 20 °C
OK Autrod 13.10 SC	Stress Relieved AWS DC+ (1.0 hour(s))	500 MPa	610 MPa	26 %	110 J @ -18 °C 80 J @ -29 °C
OK Autrod 13.10 SC	Stress Relieved EN DC+ (15.0 hour(s))	430 MPa	560 MPa	26 %	140 J @ 20 °C
OK Autrod 13.20 SC	Stress Relieved EN DC+ (1.0 hour(s))	500 MPa	615 MPa	25 %	200 J @ 20 °C 130 J @ -20 °C
OK Autrod 13.20 SC	Stress Relieved AWS DC+ (1.0 hour(s))	525 MPa	620 MPa	25 %	120 J @ -18 °C 80 J @ -29 °C
OK Autrod 13.20 SC	Stress Relieved EN DC+ (0.5 hour(s))	515 MPa	620 MPa	24 %	180 J @ 20 °C 150 J @ 0 °C
OK Autrod 13.21	Stress Relieved AWS DC+ (1.0 hour(s))	435 MPa	540 MPa	30 %	190 J @ 20 °C 180 J @ 0 °C 160 J @ -20 °C 110 J @ -40 °C 70 J @ -51 °C 60 J @ -62 °C
OK Autrod 13.21	As Welded EN AC	520 MPa	595 MPa	24 %	170 J @ 20 °C 165 J @ 0 °C 150 J @ -20 °C 70 J @ -40 °C 50 J @ -51 °C
OK Autrod 13.21	As Welded AWS DC+	470 MPa	560 MPa	28 %	195 J @ 20 °C 185 J @ 0 °C 160 J @ -20 °C 70 J @ -40 °C 60 J @ -51 °C
OK Autrod 13.24	As Welded AWS DC+	530 MPa	620 MPa	25 %	120 J @ -40 °C 110 J @ -50 °C 70 J @ -60 °C 50 J @ -73 °C
OK Autrod 13.24	Stress Relieved AWS DC+ (1.0 hour(s))	500 MPa	590 MPa	27 %	120 J @ -40 °C 100 J @ -50 °C 65 J @ -62 °C
OK Autrod 13.24	As Welded EN AC	560 MPa	640 MPa	23 %	130 J @ -40 °C 120 J @ -50 °C 80 J @ -60 °C

OK Flux 10.62

Typical Mechanical Properties					
Wire	Condition	Yield Strength	Tensile Strength	Elongation	Charpy V-Notch
OK Autrod 13.27	Stress Relieved AWS DC+ (1.0 hour(s))	460 MPa	570 MPa	28 %	150 J @ -20 °C 100 J @ -40 °C 90 J @ -60 °C 40 J @ -73 °C
OK Autrod 13.27	As Welded EN AC	520 MPa	605 MPa	27 %	150 J @ -20 °C 120 J @ -40 °C 80 J @ -60 °C 60 J @ -70 °C
OK Autrod 13.27	As Welded AWS DC+	460 MPa	570 MPa	28 %	140 J @ -20 °C 110 J @ -40 °C 80 J @ -60 °C 50 J @ -73 °C
OK Autrod 13.36	As Welded AWS DC+	500 MPa	590 MPa	27 %	70 J @ -40 °C 60 J @ -51 °C
OK Autrod 13.36	As Welded EN AC	550 MPa	620 MPa	25 %	110 J @ -40 °C 90 J @ -50 °C
OK Autrod 13.40	As Welded AWS DC+	610 MPa	690 MPa	24 %	90 J @ -40 °C 80 J @ -50 °C 50 J @ -62 °C
OK Autrod 13.40	As Welded EN AC	660 MPa	730 MPa	24 %	110 J @ -40 °C 90 J @ -50 °C 70 J @ -60 °C
OK Autrod 13.40	Stress Relieved AWS DC+ (1 hour(s))	600 MPa	680 MPa	26 %	60 J @ -40 °C 45 J @ -62 °C
OK Autrod 13.43	Stress Relieved AWS DC+ (1.0 hour(s))	695 MPa	790 MPa	21 %	80 J @ -20 °C 60 J @ -40 °C 50 J @ -50 °C 40 J @ -62 °C
OK Autrod 13.43	As Welded EN ISO-A AC	720 MPa	845 MPa	19 %	110 J @ -20 °C 90 J @ -40 °C 70 J @ -50 °C 60 J @ -60 °C
OK Autrod 13.43	As Welded AWS DC+	700 MPa	800 MPa	21 %	100 J @ -20 °C 75 J @ -40 °C 65 J @ -50 °C 50 J @ -62 °C
OK Autrod 13.49	As Welded AWS DC+	500 MPa	600 MPa	27 %	95 J @ -70 °C 40 J @ -101 °C
OK Autrod 13.49	Stress Relieved AWS DC+ (1.0 hour(s))	510 MPa	570 MPa	29 %	95 J @ -70 °C 50 J @ -101 °C
OK Autrod 13.49	As Welded EN AC	560 MPa	640 MPa	22 %	95 J @ -70 °C 75 J @ -80 °C 55 J @ -90 °C

OK Flux 10.63

Agglomerated fluoride-basic flux for Submerged Arc Welding. Designed for multi-run welding of creep resistant Cr-, Mo-alloyed steels when highest toughness values are required also after step cooling treatment. Very low level of impurities and thus exceptionally clean weld metal. X-factor max. 12, partly max. 15 with specific wires. Mainly for petrochemical and chemical industries, power generation, pressure vessels, etc. Suitable for narrow gap welding. Low-oxygen weld metal (approx. 300 ppm) with hydrogen contents lower than 5 ml/100 g. Operates optimally at the lower end of the voltage range. Designed for single and multi wire procedures, welds equally well on DC and AC current. Mainly for multi layer welding of unlimited plate thickness.

Specifications

Classifications	EN ISO 14174 : S A FB 1 55 AC H5
Diffusible Hydrogen	max 5 ml/100g weld metal (Redried flux)
Slag Type	Fluoride-basic
Alloy Transfer	No Silicon or Manganese alloying
Density	nom: 1.1 kg/dm ³
Basicity Index	nom: 3.0

Flux Consumption

Volts	kg Flux / kg Wire DC+	kg Flux / kg Wire AC
26 V	0.7 kg	0.6 kg
30 V	1.0 kg	0.9 kg
34 V	1.3 kg	1.2 kg
38 V	1.6 kg	1.4 kg

Conditions : Dimension Ø 4.0 mm , Amps 580 A , Travel Speed 55 cm/min

Classifications	Wire	Weld Metal
Wire	SFA/AWS - EN ISO	AWS - PWHT
OK Autrod 13.10 SC	A5.23:EB2R 24598-A:S S CrMo1	A5.23: F8P4-EB2R-B2R
OK Autrod 13.20 SC	A5.23:EB3R 24598-A:S S CrMo2	A5.23: F8P8-EB3R-B3R

Approvals

Wire
*Selected production units only. Please contact ESAB for more information. Visit esab.com to download specific flux/wire combination fact sheets for more details.

Typical Weld Metal Analysis %

C	Mn	Si	Cr	Mo	Mn+Si	PE	J-Factor	X-bar
OK Autrod 13.10 SC AC, 565A, 30V								
0.08	0.85	0.20	1.15	0.5	1.1	2.1	100	<= 15
OK Autrod 13.10 SC DC+, 485A, 30V								
0.075	0.8	0.25	1.1	0.5	1.1	2.1	100	<= 15
OK Autrod 13.20 SC DC+, 580A, 29V								
0.07	0.60	0.20	2.1	1.0	-	-	-	<= 15
OK Autrod 13.20 SC AC, 580A, 29V								
0.08	0.60	0.20	2.1	1.0	-	-	-	<= 15

Typical Mechanical Properties

Wire	Condition	Yield Strength	Tensile Strength	Elongation	Charpy V-Notch
OK Autrod 13.10 SC	Stress Relieved EN AC (1 hour(s))	490 MPa	590 MPa	20 %	240 J @ 20 °C 240 J @ -29 °C 150 J @ -40 °C

OK Flux 10.63

Typical Mechanical Properties					
Wire	Condition	Yield Strength	Tensile Strength	Elongation	Charpy V-Notch
OK Autrod 13.10 SC	Stress Relieved AWS DC+ (22 hour(s))	460 MPa	560 MPa	30 %	240 J @ -20 °C 150 J @ -29 °C 90 J @ -40 °C
OK Autrod 13.10 SC	Stress Relieved EN AC (22 hour(s))	450 MPa	550 MPa	32 %	300 J @ -20 °C 200 J @ -29 °C 100 J @ -40 °C
OK Autrod 13.10 SC	Stress Relieved EN AC (2 hour(s))	480 MPa	580 MPa	30 %	300 J @ -20 °C 270 J @ -29 °C 130 J @ -40 °C
OK Autrod 13.10 SC	Stress Relieved AWS DC+ (2 hour(s))	490 MPa	580 MPa	29 %	220 J @ -20 °C 150 J @ -29 °C 110 J @ -40 °C
OK Autrod 13.10 SC	Stress Relieved AWS DC+ (1 hour(s))	500 MPa	600 MPa	27 %	200 J @ -20 °C 150 J @ -29 °C 140 J @ -40 °C
OK Autrod 13.20 SC	Stress Relieved AWS DC+ (13.5 hour(s))	460 MPa	580 MPa	26 %	90 J @ -29 °C
OK Autrod 13.20 SC	Stress Relieved AWS DC+ (1.0 hour(s))	530 MPa	630 MPa	25 %	180 J @ 20 °C 150 J @ -20 °C 110 J @ -40 °C 50 J @ -62 °C
OK Autrod 13.20 SC	Stress Relieved EN DC+ (1.0 hour(s))	530 MPa	630 MPa	22 %	200 J @ 20 °C 130 J @ -20 °C 110 J @ -40 °C 40 J @ -62 °C

OK Flux 10.64

Agglomerated fluoride-basic flux for Submerged Arc Welding. Designed for multi-run welding with EB9-wire. Very low level of impurities and thus exceptionally clean weld metal. X-factor max. 12.

Specifications

Classifications	EN ISO 14174 : S A FB 1 54 DC H5
------------------------	----------------------------------

Diffusible Hydrogen	max 5 ml/100g weld metal (Redried flux)
Slag Type	Fluoride-basic
Alloy Transfer	No Silicon alloying, Manganese slightly burning off
Density	nom: 1.1 kg/dm ³ Approx.
Basicity Index	nom: 2.6

Classifications	Wire
Wire	SFA/AWS - EN ISO
OK Autrod 13.35	A5.23:EB91 24598-A:S S CrMo91

Typical Weld Metal Analysis %

C	Mn	Si	S	P	Ni	Cr	Mo	V	Al
OK Autrod 13.35 DC+, 400A, 28V (2,4 mm wire)									
0.11	0.65	0.25	0.009	0.009	0.55	8.8	0.90	0.17	0

Typical Weld Metal Analysis %

Cu	N	Nb
OK Autrod 13.35 DC+, 400A, 28V (2,4 mm wire)		
0	0.05	0.05

OK Flux 10.65

Agglomerated fluoride-basic flux for Submerged Arc Welding. Especially for combination with OK Autrod B3 SC. Designed for multi-run welding of creep resistant Cr-, Mo-alloyed steels when highest toughness values are required also after step cooling treatment. Very low level of impurities and thus exceptionally clean weld metal. X-bar max. 10 with the wire as above. Mainly for petrochemical and chemical industries, power generation, pressure vessels, etc. Suitable for narrow gap welding. Low-oxygen weld metal (approx. 300 ppm) and hydrogen contents lower than 5 ml/100 g, in BlockPac (moisture protection) maximum 4 ml/100g. Designed for single and multi wire procedures, welds equally well on DC and AC current. Mainly for multi layer welding of unlimited plate thickness.

Specifications	
Classifications	EN ISO 14174 : S A FB 1 65 AC H4 only BlockPac/moisture protection EN ISO 14174 : S A FB 1 65 AC H5
Approvals	CE : EN 13479 UKCA : EN 13479

Approvals are based on factory location. Please contact ESAB for more information.

Diffusible Hydrogen	max 5 ml/100g weld metal (Redried flux); max 4 ml/100g in BlockPac (moisture protection)
Slag Type	Fluoride-basic
Alloy Transfer	Slightly Silicon and no Manganese alloying
Density	nom: 1.0 kg/dm ³
Basicity Index	nom: 2.4

Flux Consumption		
Volts	kg Flux / kg Wire DC+	kg Flux / kg Wire AC
26 V	0.7 kg	0.6 kg
30 V	1.0 kg	0.9 kg
34 V	1.3 kg	1.2 kg
38 V	1.6 kg	1.4 kg

Conditions : Dimension Ø 4.0 mm , Amps 580 A , Travel Speed 55 cm/min

Classifications	Wire	Weld Metal
Wire	SFA/AWS - EN ISO	AWS - PWHT
OK Autrod B3 SC	A5.23:EB3R 24598-A:S S CrMo2	A5.23: F9P2-EB3R-B3R

Approvals	
Wire	CE
OK Autrod B3 SC	•

Typical Weld Metal Analysis %									
C	Mn	Si	S	P	Ni	Cr	Mo	V	Al
OK Autrod B3 SC AC, 480A, 29V, HI 1.9 kJ/mm									
0.10	0.84	0.17	0.005	0.005	0.04	2.38	0.96	0.005	0.01
OK Autrod B3 SC DC+, 480A, 29V, HI 1.9 kJ/mm									
0.09	0.93	0.23	0.006	0.005	0.04	2.30	0.96	0.005	0.01

Typical Weld Metal Analysis %									
Cu	Nb	Ti	Sb	As	B	Sn	Mn+Si	Nb+Ti+V	P+Sn
OK Autrod B3 SC AC, 480A, 29V, HI 1.9 kJ/mm									
0.05	0.002	0.002	0.001	0.002	0.0002	0.003	1.00	0.009	0.008
OK Autrod B3 SC DC+, 480A, 29V, HI 1.9 kJ/mm									

OK Flux 10.65

Typical Weld Metal Analysis %

Cu	Nb	Ti	Sb	As	B	Sn	Mn+Si	Nb+Ti+V	P+Sn
0.05	0.003	0.002	0.001	0.002	0.0002	0.003	1.15	0.009	0.008

Typical Weld Metal Analysis %

PE	J-Factor	X-bar
OK Autrod B3 SC AC, 480A, 29V, HI 1.9 kJ/mm		
3.0	85	7
OK Autrod B3 SC DC+, 480A, 29V, HI 1.9 kJ/mm		
3.1	92	7

Typical Mechanical Properties

Wire	Condition	Yield Strength	Tensile Strength	Elongation	Charpy V-Notch
OK Autrod B3 SC	PWHT AWS AC (1 hour(s))	580 MPa	700 MPa	25 %	100 J @ -30 °C
OK Autrod B3 SC	PWHT AWS AC (4 hour(s))	540 MPa	650 MPa	25 %	170 J @ -30 °C
OK Autrod B3 SC	PWHT AWS DC+ (1 hour(s))	580 MPa	690 MPa	17 %	100 J @ -30 °C
OK Autrod B3 SC	PWHT AWS DC+ (4 hour(s))	520 MPa	640 MPa	26 %	130 J @ -30 °C
OK Autrod B3 SC	PWHT AWS AC (32 hour(s))	460 MPa	590 MPa	29 %	170 J @ -30 °C
OK Autrod B3 SC	PWHT AWS DC+ (32 hour(s))	440 MPa	570 MPa	28 %	100 J @ -30 °C
OK Autrod B3 SC	PWHT EN ISO AC (1 hour(s))	560 MPa	680 MPa	18 %	200 J @ 20 °C

OK Flux 10.66

Agglomerated fluoride-basic flux for Submerged Arc Welding. Especially for combination with OK Autrod B2 SC. Designed for multi-run welding of creep resistant Cr-, Mo-alloyed steels when highest toughness values are required also after step cooling treatment. Very low level of impurities and thus exceptionally clean weld metal. X-bar max. 10 with the wire as above. Mainly for petrochemical and chemical industries, power generation, pressure vessels, etc. Very good slag release, as well in narrow gap joints. Low-oxygen weld metal (approx. 300 ppm) and hydrogen contents maximum 5 ml/100 g, Designed for single and multi wire procedures, welds equally well on DC and AC current. Mainly for multi layer welding of unlimited plate thickness.

Specifications	
Classifications	EN ISO 14174 : S A FB 1 55 AC H5
Approvals	CE : EN 13479 UKCA : EN 13479

Approvals are based on factory location. Please contact ESAB for more information.

Diffusible Hydrogen	max 5 ml/100g weld metal (Redried flux)
Slag Type	Fluoride-basic
Alloy Transfer	No Silicon or Manganese alloying
Density	nom: 1.0 kg/dm ³
Basicity Index	nom: 2.3

Flux Consumption		
Volts	kg Flux / kg Wire DC+	kg Flux / kg Wire AC
26 V	0.7 kg	0.6 kg
30 V	1.0 kg	0.9 kg
34 V	1.3 kg	1.2 kg
38 V	1.6 kg	1.4 kg

Conditions : Dimension Ø 4.0 mm , Amps 580 A , Travel Speed 55 cm/min

Classifications	Wire	Weld Metal
Wire	SFA/AWS - EN ISO	AWS - PWHT
OK Autrod B2 SC	A5.23:EB2R 24598-A:S S CrMo1	A5.23: F8P4-EB2R-B2R

Approvals	
Wire	CE
OK Autrod B2 SC	•

Typical Weld Metal Analysis %									
C	Mn	Si	S	P	Ni	Cr	Mo	V	Al
OK Autrod B2 SC DC+, 540A, 29V, HI 1.9 kJ/mm									
0.06	0.85	0.19	0.006	0.005	0.03	1.08	0.44	0.004	0.01
OK Autrod B2 SC AC, 540A, 29V, HI 1.9 kJ/mm									
0.08	0.79	0.16	0.005	0.004	0.03	1.12	0.44	0.004	0.01

Typical Weld Metal Analysis %									
Cu	Nb	Ti	Sb	As	B	Sn	Mn+Si	Nb+Ti+V	P+Sn
OK Autrod B2 SC DC+, 540A, 29V, HI 1.9 kJ/mm									
0.04	0.002	0.008	0.001	0.001	0.0002	0.002	1.04	0.014	0.006
OK Autrod B2 SC AC, 540A, 29V, HI 1.9 kJ/mm									
0.03	0.001	0.010	0.001	0.001	0.0002	0.002	0.95	0.016	0.006

OK Flux 10.66

Typical Weld Metal Analysis %

PE	J-Factor	X-bar
OK Autrod B2 SC DC+, 540A, 29V, HI 1.9 kJ/mm		
2.0	70	6
OK Autrod B2 SC AC, 540A, 29V, HI 1.9 kJ/mm		
1.9	52	5

Typical Mechanical Properties

Wire	Condition	Yield Strength	Tensile Strength	Elongation	Charpy V-Notch
OK Autrod B2 SC	PWHT AWS DC+ (2 hour(s))	420 MPa	530 MPa	32 %	170 J @ -30 °C
OK Autrod B2 SC	PWHT AWS AC (2 hour(s))	460 MPa	560 MPa	29 %	200 J @ -30 °C
OK Autrod B2 SC	PWHT AWS DC+ (1 hour(s))	470 MPa	560 MPa	17 %	40 J @ -40 °C
OK Autrod B2 SC	PWHT AWS DC+ (22 hour(s))	400 MPa	515 MPa	32 %	220 J @ -30 °C
OK Autrod B2 SC	PWHT EN ISO AC (1 hour(s))	480 MPa	570 MPa	24 %	220 J @ 20 °C
OK Autrod B2 SC	PWHT AWS AC (22 hour(s))	430 MPa	530 MPa	31 %	250 J @ -30 °C

OK Flux 10.69

Agglomerated basic flux specially designed as a backing flux for one-sided Submerged Arc Welding. Perfect root formation with smooth route surface. Good capability to support the molten pool even at high heat inputs. Mainly for shipbuilding industries. A copper bar with groove is normally used to support the flux.

Specifications

Classifications	EN ISO 14174 : S A CS 4
Slag Type	Calcium-silicate
Alloy Transfer	No alloying
Density	nom: 1.3 kg/dm ³
Basicity Index	nom: 1.8

OK Flux 10.70

Agglomerated aluminate-basic flux for Submerged Arc Welding particular for applications with high dilution from the base material, e.g. butt welds with one run from each side or fillet welds. Good impact properties due to high alloying of Mn and Si. Especially designed to use with OK Autrod 12.10, OK Autrod 12.20 and similar. Mainly for shipbuilding, also for pressure vessels, transport industries, general constructions, etc. Suitable for single and multi wire procedures, for DC and AC welding. Intended for a limited number of passes and plate thickness up to about 25 mm.

Specifications

Classifications	EN ISO 14174 : S A AB 1 79 AC
Approvals	CE : EN 13479 DB : 51.039.06 UKCA : EN 13479

Approvals are based on factory location. Please contact ESAB for more information.

Slag Type	Aluminate-basic
Alloy Transfer	Moderately Silicon and very high Manganese alloying
Density	nom: 1.2 kg/dm ³
Basicity Index	nom: 1.4

Flux Consumption

Volts	kg Flux / kg Wire DC+	kg Flux / kg Wire AC
26 V	0.7 kg	0.6 kg
30 V	1.0 kg	0.9 kg
34 V	1.3 kg	1.2 kg
38 V	1.6 kg	1.4 kg

Conditions : Dimension Ø 4.0 mm , Amps 580 A , Travel Speed 55 cm/min

Classifications	Wire	Weld Metal		
		EN - As Welded	AWS - As Welded	AWS - PWHT
OK Autrod 12.10	A5.17:EL12 14171-A:S1	14171-A: S 42 3 AB S1	A5.17: F7A4-EL12	A5.17: F7P4-EL12
OK Autrod 12.20	A5.17:EM12 14171-A:S2	14171-A: S 46 3 AB S2	A5.17: F7A2-EM12	A5.17: F7P2-EM12
OK Autrod 12.24	A5.23:EA2 14171-A:S2Mo 24598-A:S S Mo	14171-A: S 50 0 AB S2Mo	A5.23: F9A0-EA2-A3	A5.23: F9PZ-EA2-A3

Approvals

Wire	ABS	BV	CE	DB	DNV	GL	LR	PRS	RS	VdTÜV
OK Autrod 12.10	•	•	•	•	•	•	•	•	•	•
OK Autrod 12.20	-	-	•	•	-	-	-	-	-	•

Typical Weld Metal Analysis %

C	Mn	Si	Mo
OK Autrod 12.10 DC+ , 580A, 29V			
0.05	1.7	0.5	-
OK Autrod 12.10 AC , 580A, 29V			
0.06	1.6	0.5	-
OK Autrod 12.20 AC, 580A, 29V			
0.07	1.8	0.5	-
OK Autrod 12.20 DC+, 580A, 29V			
0.06	1.9	0.6	-
OK Autrod 12.24 AC, 580A, 29V			

OK Flux 10.70

Typical Weld Metal Analysis %

C	Mn	Si	Mo
0.07	1.8	0.5	0.5
OK Autrod 12.24 DC+, 580A, 29V			
0.06	2.0	0.6	0.5

Typical Mechanical Properties

Wire	Condition	Yield Strength	Tensile Strength	Elongation	Charpy V-Notch
OK Autrod 12.10	As Welded EN AC	450 MPa	530 MPa	28 %	150 J @ 20 °C 120 J @ 0 °C 90 J @ -20 °C 65 J @ -30 °C
OK Autrod 12.10	As Welded AWS DC+	430 MPa	520 MPa	30 %	125 J @ 20 °C 100 J @ 0 °C 70 J @ -20 °C 55 J @ -30 °C 40 J @ -40 °C
OK Autrod 12.10	Stress Relieved AWS DC+ (1.0 hour(s))	410 MPa	510 MPa	30 %	110 J @ 20 °C 90 J @ 0 °C 65 J @ -20 °C 35 J @ -40 °C
OK Autrod 12.20	As Welded EN AC	490 MPa	590 MPa	27 %	120 J @ 20 °C 110 J @ 0 °C 90 J @ -20 °C 60 J @ -30 °C
OK Autrod 12.20	As Welded AWS DC+	470 MPa	580 MPa	29 %	100 J @ 20 °C 90 J @ 0 °C 75 J @ -20 °C 50 J @ -29 °C
OK Autrod 12.20	Stress Relieved AWS DC+ (1.0 hour(s))	430 MPa	550 MPa	28 %	100 J @ 20 °C 80 J @ 0 °C 60 J @ -20 °C 40 J @ -29 °C
OK Autrod 12.24	Stress Relieved AWS DC+ (1.0 hour(s))	560 MPa	660 MPa	24 %	60 J @ 20 °C 40 J @ 0 °C
OK Autrod 12.24	As Welded AWS DC+	580 MPa	670 MPa	23 %	60 J @ 20 °C 50 J @ 0 °C 40 J @ -18 °C
OK Autrod 12.24	As Welded EN AC	630 MPa	700 MPa	25 %	80 J @ 20 °C 60 J @ 0 °C 45 J @ -20 °C

OK Flux 10.71

Agglomerated aluminate-basic flux for Submerged Arc Welding. General purpose flux with excellent welding performance, suitable for all kinds of steels. High impact toughness values. Fits to a large range of SAW wires. For general constructions, pressure vessels, shipbuilding, pipe mills, wind tower productions, transport industries, etc. Designed for single and multi wire procedures, for butt and fillet welds. Suitable for DC and AC welding. Single layer and multi layer welding of unlimited plate thickness.

Specifications	
Classifications	EN ISO 14174 : S A AB 1 67 AC H5
Approvals	CE : EN 13479 DB : 51.039.05 UKCA : EN 13479

Approvals are based on factory location. Please contact ESAB for more information.

Diffusible Hydrogen	max 5 ml/100g weld metal (Redried flux)
Slag Type	Aluminate-basic
Alloy Transfer	Slightly Silicon and moderately Manganese alloying
Density	nom: 1.2 kg/dm ³
Basicity Index	nom: 1.5

Flux Consumption		
Volts	kg Flux / kg Wire DC+	kg Flux / kg Wire AC
26 V	0.7 kg	0.6 kg
30 V	1.0 kg	0.9 kg
34 V	1.3 kg	1.2 kg
38 V	1.6 kg	1.4 kg

Conditions : Dimension Ø 4.0 mm , Amps 580 A , Travel Speed 55 cm/min

Classifications	Wire	Weld Metal		
		EN - As Welded	AWS - As Welded	AWS - PWHT
OK Autrod 12.10	A5.17:EL12 14171-A:S1	14171-A: S 35 4 AB S1	A5.17: F6A4-EL12	A5.17: F6P5-EL12
OK Autrod 12.20	A5.17:EM12 14171-A:S2	14171-A: S 38 4 AB S2	A5.17: F7A4-EM12	A5.17: F6P4-EM12
OK Autrod 12.22	A5.17:EM12K 14171-A:S2Si	14171-A: S 38 4 AB S2Si	A5.17: F7A5-EM12K	A5.17: F6P5-EM12K
OK Autrod 12.24	A5.23:EA2 14171-A:S2Mo; 24598-A:S S Mo	14171-A: S 46 2 AB S2Mo	A5.23: F8A2-EA2-A4	A5.23: F7P0-EA2-A4
OK Autrod 12.30	14171-A:S3	14171-A: S 46 3 AB S3	-	-
OK Autrod 12.32	A5.17:EH12K 14171-A:S3Si	14171-A: S 46 4 AB S3Si	A5.17: F7A5-EH12K	A5.17: F7P5-EH12K
OK Autrod 12.34	A5.23:EA4 14171-A:S3Mo; 24598-A:S S MnMo	14171-A: S 50 3 AB S3Mo	A5.23: F8A4-EA4-A3	A5.23: F8P2-EA4-A3
OK Autrod 13.24	A5.23:ENi6 14171-A:S3Ni1Mo0,2	14171-A: S 50 4 AB S3Ni1Mo0,2	A5.23: F8A5-ENi6-Ni6	A5.23: F8P4-ENi6-Ni6
OK Autrod 13.27	A5.23:ENi2 14171-A:S2Ni2	14171-A: S 46 5 AB S2Ni2	A5.23: F8A6-ENi2-Ni2	A5.23: F7P6-ENi2-Ni2
OK Autrod 13.36	A5.23:EG 14171-A:S2Ni1Cu	14171-A: S 46 3 AB S2Ni1Cu	A5.23: F8A2-EG-G	-
OK Autrod 13.62	A5.23:EG 14171-A:SZ3TiB	-	A5.23: F8TA6-EG	-

OK Flux 10.71

Classifications	Wire	Weld Metal		
Wire	SFA/AWS - EN ISO	EN - As Welded	AWS - As Welded	AWS - PWHT
OK Autrod 13.64	A5.23:EA2TiB 14171-A:S2MoTiB	-	A5.23: F8TA6-EA2TiB	-

Approvals

Wire	ABS	BV	CE	ClassNK	DB	DNV	GL	LR	PRS	RINA	RS	VdTÜV
OK Autrod 12.10	•	•	•	-	•	•	•	•	•	-	•	•
OK Autrod 12.20	•	•	•	-	•	•	•	•	•	•	•	•
OK Autrod 12.22	•	•	•	•	•	•	•	•	-	-	•	•
OK Autrod 12.24	•	•	•	•	•	•	•	•	•	•	•	•
OK Autrod 12.30	-	-	•	-	•	-	-	-	-	-	-	•
OK Autrod 12.32	-	-	•	-	•	-	-	-	-	-	-	•
OK Autrod 13.27	-	-	-	-	-	-	-	-	-	-	-	•
OK Autrod 13.36	-	-	•	-	-	-	-	-	-	-	-	-

Typical Weld Metal Analysis %

C	Mn	Si	Ni	Cr	Mo	Cu	Ti	B
OK Autrod 12.10 AC , 580A, 29V								
0.05	0.85	0.2	-	-	-	-	-	-
OK Autrod 12.10 DC+ , 580A, 29V								
0.04	1.0	0.3	-	-	-	-	-	-
OK Autrod 12.20 AC, 580A, 29V								
0.06	1.2	0.2	-	-	-	-	-	-
OK Autrod 12.20 DC+, 580A, 29V								
0.05	1.35	0.3	-	-	-	-	-	-
OK Autrod 12.22 AC, 580A, 29V								
0.06	1.2	0.4	-	-	-	-	-	-
OK Autrod 12.22 DC+, 580A, 29V								
0.05	1.4	0.5	-	-	-	-	-	-
OK Autrod 12.24 AC, 580A, 29V								
0.06	1.3	0.25	-	-	0.5	-	-	-
OK Autrod 12.24 DC+, 580A, 29V								
0.05	1.4	0.4	-	-	0.5	-	-	-
OK Autrod 12.30 AC, 580A, 29V								
0.10	1.6	0.3	-	-	-	-	-	-
OK Autrod 12.30 DC+, 580A, 29V								
0.09	1.65	0.4	-	-	-	-	-	-
OK Autrod 12.32 AC, 580A, 29V								
0.10	1.9	0.35	-	-	-	-	-	-
OK Autrod 12.32 DC+, 580A, 29V								
0.09	2.0	0.5	-	-	-	-	-	-
OK Autrod 12.34 AC, 580A, 29V								
0.10	1.5	0.25	-	-	0.5	-	-	-
OK Autrod 12.34 DC+, 580A, 29V								
0.09	1.6	0.4	-	-	0.5	-	-	-
OK Autrod 13.24 AC , 580A, 29V								
0.09	1.50	0.45	0.9	-	0.2	-	-	-
OK Autrod 13.24 DC+, 580A, 29V								

OK Flux 10.71

Typical Weld Metal Analysis %

C	Mn	Si	Ni	Cr	Mo	Cu	Ti	B
0.07	1.70	0.5	0.9	-	0.2	-	-	-
OK Autrod 13.27 AC, 580A, 29V								
0.06	1.3	0.3	2.2	-	-	-	-	-
OK Autrod 13.27 DC+, 580A, 29V								
0.05	1.4	0.4	2.2	-	-	-	-	-
OK Autrod 13.36 AC, 580A, 29V								
0.09	1.2	0.4	0.7	0.3	-	0.5	-	-
OK Autrod 13.36 DC+, 580A, 29V								
0.08	1.3	0.5	0.7	0.3	-	0.5	-	-
OK Autrod 13.64								
0.05	1.4	0.5	-	-	0.5	-	0.15	0.015
0.06	1.2	0.4	-	-	0.5	-	0.15	0.015

Typical Mechanical Properties

Wire	Condition	Yield Strength	Tensile Strength	Elongation	Charpy V-Notch
OK Autrod 12.10	Stress Relieved AWS DC+ (1.0 hour(s))	330 MPa	430 MPa	32 %	110 J @ 0 °C 90 J @ -20 °C 75 J @ -30 °C 60 J @ -40 °C 35 J @ -46 °C
OK Autrod 12.10	As Welded AWS DC+	360 MPa	465 MPa	30 %	125 J @ 0 °C 95 J @ -20 °C 75 J @ -30 °C 65 J @ -40 °C
OK Autrod 12.10	As Welded EN AC	385 MPa	470 MPa	30 %	150 J @ 0 °C 120 J @ -20 °C 85 J @ -30 °C 70 J @ -40 °C
OK Autrod 12.20	Stress Relieved AWS DC+ (1.0 hour(s))	390 MPa	500 MPa	30 %	100 J @ 20 °C 90 J @ 0 °C 55 J @ -20 °C 30 J @ -40 °C
OK Autrod 12.20	As Welded AWS DC+	410 MPa	510 MPa	29 %	135 J @ 20 °C 125 J @ 0 °C 80 J @ -20 °C 55 J @ -40 °C
OK Autrod 12.20	As Welded EN AC	430 MPa	535 MPa	33 %	150 J @ 20 °C 130 J @ 0 °C 115 J @ -20 °C 70 J @ -40 °C
OK Autrod 12.22	As Welded AWS DC+	425 MPa	520 MPa	29 %	140 J @ 0 °C 100 J @ -20 °C 60 J @ -40 °C 40 J @ -46 °C
OK Autrod 12.22	As Welded EN AC	460 MPa	550 MPa	28 %	145 J @ 0 °C 125 J @ -20 °C 90 J @ -40 °C
OK Autrod 12.22	Stress Relieved AWS DC+ (1.0 hour(s))	390 MPa	500 MPa	32 %	120 J @ 0 °C 80 J @ -20 °C 65 J @ -40 °C 45 J @ -46 °C

OK Flux 10.71

Typical Mechanical Properties					
Wire	Condition	Yield Strength	Tensile Strength	Elongation	Charpy V-Notch
OK Autrod 12.24	Stress Relieved AWS DC+ (1.0 hour(s))	480 MPa	560 MPa	25 %	100 J @ 20 °C 70 J @ 0 °C 40 J @ -18 °C 25 J @ -29 °C
OK Autrod 12.24	As Welded EN AC	550 MPa	620 MPa	23 %	130 J @ 20 °C 110 J @ 0 °C 70 J @ -20 °C 40 J @ -40 °C
OK Autrod 12.24	As Welded AWS DC+	500 MPa	580 MPa	24 %	125 J @ 20 °C 100 J @ 0 °C 60 J @ -18 °C 40 J @ -29 °C
OK Autrod 12.30	As Welded EN AC	510 MPa	590 MPa	28 %	140 J @ 20 °C 120 J @ 0 °C 100 J @ -20 °C 70 J @ -30 °C
OK Autrod 12.30	Stress Relieved EN DC+ (1.0 hour(s))	460 MPa	550 MPa	29 %	125 J @ 20 °C 105 J @ 0 °C 85 J @ -20 °C 50 J @ -30 °C
OK Autrod 12.30	As Welded EN DC+	490 MPa	580 MPa	29 %	130 J @ 20 °C 110 J @ 0 °C 90 J @ -20 °C 60 J @ -30 °C
OK Autrod 12.32	Stress Relieved AWS DC+ (1.0 hour(s))	470 MPa	570 MPa	28 %	135 J @ 20 °C 125 J @ 0 °C 95 J @ -20 °C 50 J @ -40 °C 35 J @ -46 °C
OK Autrod 12.32	As Welded AWS DC+	480 MPa	580 MPa	28 %	150 J @ 20 °C 130 J @ 0 °C 95 J @ -20 °C 65 J @ -40 °C 40 J @ -46 °C
OK Autrod 12.32	As Welded EN AC	530 MPa	615 MPa	28 %	140 J @ 20 °C 120 J @ 0 °C 100 J @ -20 °C 60 J @ -40 °C
OK Autrod 12.34	As Welded EN AC	560 MPa	635 MPa	23 %	135 J @ 20 °C 120 J @ 0 °C 100 J @ -20 °C 80 J @ -30 °C 60 J @ -40 °C
OK Autrod 12.34	As Welded AWS DC+	535 MPa	620 MPa	27 %	120 J @ 20 °C 105 J @ 0 °C 70 J @ -20 °C 60 J @ -30 °C 45 J @ -40 °C
OK Autrod 12.34	Stress Relieved AWS DC+ (1.0 hour(s))	505 MPa	605 MPa	26 %	110 J @ 20 °C 85 J @ 0 °C 55 J @ -20 °C 40 J @ -29 °C

OK Flux 10.71

Typical Mechanical Properties

Wire	Condition	Yield Strength	Tensile Strength	Elongation	Charpy V-Notch
OK Autrod 13.24	Stress Relieved AWS DC+ (1.0 hour(s))	520 MPa	610 MPa	28 %	135 J @ 20 °C 65 J @ -20 °C 60 J @ -30 °C 40 J @ -40 °C
OK Autrod 13.24	As Welded AWS DC+	560 MPa	630 MPa	25 %	120 J @ 20 °C 85 J @ -20 °C 70 J @ -30 °C 60 J @ -40 °C 40 J @ -46 °C
OK Autrod 13.24	As Welded EN AC	610 MPa	680 MPa	25 %	150 J @ 20 °C 120 J @ -20 °C 100 J @ -30 °C 90 J @ -40 °C
OK Autrod 13.27	As Welded EN AC	530 MPa	620 MPa	28 %	120 J @ -20 °C 90 J @ -40 °C 60 J @ -50 °C
OK Autrod 13.27	Stress Relieved AWS DC+ (1.0 hour(s))	460 MPa	550 MPa	29 %	105 J @ -20 °C 60 J @ -40 °C 50 J @ -51 °C
OK Autrod 13.27	As Welded AWS DC+	500 MPa	600 MPa	28 %	100 J @ -20 °C 60 J @ -40 °C 50 J @ -51 °C
OK Autrod 13.36	As Welded EN AC	515 MPa	590 MPa	27 %	150 J @ 20 °C 90 J @ -20 °C 80 J @ -30 °C
OK Autrod 13.36	As Welded AWS DC+	490 MPa	580 MPa	27 %	120 J @ 20 °C 70 J @ -20 °C 55 J @ -29 °C
OK Autrod 13.62	Two Run. As Welded (acc. AWS) Plate thickness 12mm; Heat Input 2.2kJ/mm; Side 1 600A, 32V, 53cm/min; Side 2 700A, 32V, 60cm/min. DC+	510 MPa	610 MPa	28 %	40 J @ -51 °C
OK Autrod 13.64	Two Run. As Welded (acc. to AWS) Plate thickness 12mm Heat input 2.2kJ /mm 700A, 32V, 60cm /min DC+	550 MPa	650 MPa	28 %	40 J @ -51 °C

OK Flux 10.72

Agglomerated aluminate-basic flux for Submerged Arc Welding especially for applications with toughness requirements at low temperature. Excellent slag removal also in narrow V-joints. For wind tower productions, pressure vessels, general constructions etc. Extremely high current carrying capacity. For single or multi wire procedures. Suitable for DC and AC welding. Single layer and multi layer welding of unlimited plate thickness.

Specifications	
Classifications	EN ISO 14174 : S A AB 1 57 AC H5
Approvals	CE : EN 13479 DB : 51.039.12 UKCA : EN 13479

Approvals are based on factory location. Please contact ESAB for more information.

Diffusible Hydrogen	max 5 ml/100g weld metal (Redried flux)
Slag Type	Aluminate-basic
Alloy Transfer	No Silicon and moderately Manganese alloying
Density	nom: 1.2 kg/dm ³
Basicity Index	nom: 1.9

Flux Consumption		
Volts	kg Flux / kg Wire DC+	kg Flux / kg Wire AC
26 V	0.7 kg	0.6 kg
30 V	1.0 kg	0.9 kg
34 V	1.3 kg	1.2 kg
38 V	1.6 kg	1.4 kg

Conditions : Dimension Ø 4.0 mm , Amps 580 A , Travel Speed 55 cm/min

Classifications	Wire	Weld Metal		
		EN - As Welded	AWS - As Welded	AWS - PWHT
OK Autrod 12.20	A5.17:EM12 14171-A:S2	14171-A: S 38 5 AB S2	A5.17: F7A8-EM12	A5.17: F6P8-EM12
OK Autrod 12.22	A5.17:EM12K 14171-A:S2Si	14171-A: S 42 5 AB S2Si	A5.17: F7A8-EM12K	A5.17: F6P8-EM12K
OK Autrod 12.24	A5.23:EA2 14171-A:S2Mo; 24598-A:S S Mo	14171-A: S 46 3 AB S2Mo	A5.23: F8A5-EA2-A3	A5.23: F8P5-EA2-A3
OK Autrod 13.24	A5.23:ENi6 14171-A:S3Ni1Mo0,2	-	A5.23: F8TA4-ENi6	-
OK Autrod 13.27	A5.23:ENi2 14171-A:S2Ni2	14171-A: S 46 6 AB S2Ni2	A5.23: F8A8-ENi2-Ni2	A5.23: F7P8-ENi2-Ni2
OK Autrod 13.62	A5.23:EG 14171-A:SZ3TiB	-	A5.23: F8TA8-EG	-
OK Autrod 13.64	A5.23:EA2TiB 14171-A:S2MoTiB	-	A5.23: F8TA8-EA2TiB	-

Approvals						
Wire	ABS	CE	DB	DNV	VdTÜV	
OK Autrod 12.20	-	•	•	-	•	
OK Autrod 12.22	•	•	•	•	•	
OK Autrod 12.24	-	•	•	-	•	
OK Autrod 13.27	-	•	-	-	-	

OK Flux 10.72

Typical Weld Metal Analysis %

C	Mn	Si	Ni	Mo
OK Autrod 12.20 AC, 580A, 29V				
0.06	1.4	0.2	-	-
OK Autrod 12.20 DC+, 580A, 29V				
0.05	1.5	0.2	-	-
OK Autrod 12.22 AC, 580A, 29V				
0.08	1.4	0.3	-	-
OK Autrod 12.22 DC+, 580A, 29V				
0.05	1.5	0.3	-	-
OK Autrod 12.24 AC, 580A, 29V				
0.06	1.5	0.2	-	0.5
OK Autrod 12.24 DC+, 580A, 29V				
0.05	1.6	0.2	-	0.5
OK Autrod 13.27 AC, 580A, 29V				
0.07	1.4	0.30	2.2	-
OK Autrod 13.27 DC+, 520A, 29V				
0.05	1.4	0.30	2.2	-

Typical Mechanical Properties

Wire	Condition	Yield Strength	Tensile Strength	Elongation	Charpy V-Notch
OK Autrod 12.20	As Welded AWS DC+	415 MPa	500 MPa	30 %	125 J @ -30 °C 100 J @ -40 °C 70 J @ -50 °C 50 J @ -62 °C
OK Autrod 12.20	Stress Relieved AWS DC+ (1.0 hour(s))	360 MPa	460 MPa	32 %	130 J @ -30 °C 110 J @ -40 °C 70 J @ -50 °C 50 J @ -62 °C
OK Autrod 12.20	As Welded EN AC	420 MPa	500 MPa	33 %	140 J @ -30 °C 130 J @ -40 °C 80 J @ -50 °C
OK Autrod 12.22	As Welded AWS DC+	440 MPa	530 MPa	31 %	120 J @ -30 °C 100 J @ -40 °C 70 J @ -50 °C 50 J @ -62 °C
OK Autrod 12.22	As Welded EN AC	425 MPa	560 MPa	27 %	140 J @ -30 °C 130 J @ -40 °C 80 J @ -50 °C
OK Autrod 12.22	Stress Relieved AWS DC+ (1.0 hour(s))	375 MPa	475 MPa	33 %	130 J @ -30 °C 110 J @ -40 °C 70 J @ -50 °C 50 J @ -62 °C
OK Autrod 12.24	Stress Relieved AWS DC+ (1.0 hour(s))	490 MPa	580 MPa	25 %	60 J @ -30 °C 40 J @ -40 °C 35 J @ -46 °C
OK Autrod 12.24	As Welded AWS DC+	500 MPa	590 MPa	25 %	60 J @ -30 °C 40 J @ -40 °C 35 J @ -46 °C
OK Autrod 12.24	As Welded EN AC	535 MPa	600 MPa	24 %	70 J @ -30 °C 50 J @ -40 °C 40 J @ -50 °C

OK Flux 10.72

Typical Mechanical Properties					
Wire	Condition	Yield Strength	Tensile Strength	Elongation	Charpy V-Notch
OK Autrod 13.24	Two Run. As Welded (acc. AWS) Plate thickness 12mm; Heat Input: 2.2kJ/mm; Side 1: 600A, 32V, 52cm/min; Side 2: 700A, 32V, 60cm/min; DC+	530 MPa	660 MPa	28 %	90 J @ 0 °C 35 J @ -40 °C
OK Autrod 13.27	Stress Relieved AWS DC+ (1 hour(s))	450 MPa	560 MPa	32 %	110 J @ -40 °C 90 J @ -51 °C 60 J @ -62 °C
OK Autrod 13.27	As Welded EN AC	520 MPa	610 MPa	27 %	120 J @ -30 °C 100 J @ -40 °C 80 J @ -50 °C 60 J @ -60 °C
OK Autrod 13.27	As Welded AWS DC+	490 MPa	610 MPa	30 %	100 J @ -40 °C 80 J @ -51 °C 50 J @ -62 °C
OK Autrod 13.62	Two Run. As Welded (acc. AWS) Plate thickness: 12mm; Heat Input: 2.2 kJ/mm; Side 1: 600A, 32V, 53cm/min; Side 2: 700A, 32V, 60cm/min; DC+	500 MPa	610 MPa	27 %	50 J @ -62 °C
OK Autrod 13.64	Two Run. As Welded (acc. to AWS) Plate thickness 12mm Heat input 2.2kJ /mm 700A, 32V, 60cm /min DC+	560 MPa	660 MPa	27 %	50 J @ -62 °C

OK Flux 10.74

Agglomerated aluminate-basic flux for Submerged Arc Welding especially for multi wire procedures in the production of longitudinal welded line pipes. Low weld bead profile at high welding speeds. With various wires suitable for all pipe steels. Due to the careful metallurgical design it produces a hard-spot free weld metal. Suitable for DC and AC welding of unlimited plate thickness.

Specifications

Classifications	EN ISO 14174 : S A AB 1 67 AC H5
Diffusible Hydrogen	max 5 ml/100g weld metal (Redried flux)
Slag Type	Aluminate-basic
Alloy Transfer	Slightly Silicon and moderately Manganese alloying
Density	nom: 1.2 kg/dm ³
Basicity Index	nom: 1.4

Flux Consumption

Volts	kg Flux / kg Wire DC+	kg Flux / kg Wire AC
26 V	0.7 kg	0.6 kg
30 V	1.0 kg	0.9 kg
34 V	1.3 kg	1.2 kg
38 V	1.6 kg	1.4 kg

Conditions : Dimension Ø 4.0 mm , Amps 580 A , Travel Speed 55 cm/min

Classifications	Wire	Weld Metal		
		EN - As Welded	AWS - As Welded	AWS - PWHT
OK Autrod 12.20	A5.17:EM12 14171-A:S2	14171-A: S 42 4 AB S2	A5.17: F7A6-EM12	A5.17: F6P6-EM12
OK Autrod 12.22	A5.17:EM12K 14171-A:S2Si	14171-A: S 42 4 AB S2Si	A5.23: F8TA4G-EM12K	A5.17: F6P6-EM12K
OK Autrod 12.24	A5.23:EA2 14171-A:S2Mo; 24598-A:S S Mo	14171-A: S 46 2 AB S2Mo	A5.23: F8A2-EA2-A4	A5.23: F7P0-EA2-A4
OK Autrod 12.34	A5.23:EA4 14171-A:S3Mo; 24598-A:S S MnMo	14171-A: S 50 2 AB S3Mo	A5.23: F9A2-EA4-A3	A5.23: F9P0-EA4-A3
OK Autrod 13.62	A5.23:EG 14171-A:SZ3TiB	-	A5.23: F8TA6-EG	-
OK Autrod 13.64	A5.23:EA2TiB 14171-A:S2MoTiB	-	A5.23: F8TA6-EA2TiB	-

Approvals

Wire
*Selected production units only. Please contact ESAB for more information. Visit esab.com to download specific flux/wire combination fact sheets for more details.

Typical Weld Metal Analysis %

C	Mn	Si	Mo
OK Autrod 12.20 AC, 580A, 29V			
0.08	1.3	0.2	-
OK Autrod 12.20 DC+, 580A, 29V			
0.07	1.5	0.3	-
OK Autrod 12.22 AC, 580A, 29V			
0.08	1.3	0.4	-
OK Autrod 12.22 DC+, 580A, 29V			

OK Flux 10.74

Typical Weld Metal Analysis %

C	Mn	Si	Mo
0.07	1.5	0.5	-
OK Autrod 12.24 AC, 580A, 29V			
0.06	1.3	0.3	0.5
OK Autrod 12.24 DC+, 580A, 29V			
0.05	1.4	0.4	0.5
OK Autrod 12.34 AC, 580A, 29V			
0.09	1.5	0.3	0.5
OK Autrod 12.34 DC+, 580A, 29V			
0.08	1.6	0.4	0.5

Typical Mechanical Properties

Wire	Condition	Yield Strength	Tensile Strength	Elongation	Charpy V-Notch
OK Autrod 12.20	As Welded EN AC	450 MPa	540 MPa	27 %	110 J @ -20 °C 80 J @ -30 °C 60 J @ -40 °C
OK Autrod 12.20	Stress Relieved AWS DC+ (1.0 hour(s))	400 MPa	500 MPa	31 %	70 J @ -40 °C 45 J @ -51 °C
OK Autrod 12.20	As Welded AWS DC+	440 MPa	540 MPa	30 %	60 J @ -40 °C 40 J @ -51 °C
OK Autrod 12.22	As Welded Two-run acc. to AWS; X70-plate, thickness 12mm; Heat input 2.2 kJ/mm; 700A, 32V, 60cm/min DC+	530 MPa	640 MPa	27 %	150 J @ 0 °C 110 J @ -30 °C 60 J @ -40 °C
OK Autrod 12.22	As Welded AWS DC+	440 MPa	540 MPa	30 %	55 J @ -40 °C 35 J @ -51 °C
OK Autrod 12.22	As Welded EN AC	460 MPa	550 MPa	26 %	110 J @ -20 °C 80 J @ -30 °C 60 J @ -40 °C
OK Autrod 12.22	Stress Relieved AWS DC+ (1.0 hour(s))	390 MPa	490 MPa	31 %	70 J @ -40 °C 40 J @ -51 °C
OK Autrod 12.24	Stress Relieved AWS DC+ (1.0 hour(s))	500 MPa	580 MPa	27 %	70 J @ 0 °C 50 J @ -18 °C 30 J @ -29 °C
OK Autrod 12.24	As Welded AWS DC+	520 MPa	590 MPa	24 %	100 J @ 0 °C 65 J @ -20 °C 50 J @ -29 °C 30 J @ -40 °C
OK Autrod 12.24	As Welded EN AC	550 MPa	620 MPa	23 %	120 J @ 0 °C 80 J @ -20 °C 50 J @ -40 °C
OK Autrod 12.34	As Welded EN AC	620 MPa	680 MPa	23 %	100 J @ 0 °C 80 J @ -20 °C 60 J @ -30 °C
OK Autrod 12.34	As Welded AWS DC+	590 MPa	670 MPa	24 %	90 J @ 0 °C 60 J @ -18 °C 55 J @ -20 °C 40 J @ -29 °C
OK Autrod 12.34	Stress Relieved AWS DC+ (1.0 hour(s))	570 MPa	650 MPa	25 %	70 J @ 0 °C 35 J @ -18 °C



OK Flux 10.74

Typical Mechanical Properties

Wire	Condition	Yield Strength	Tensile Strength	Elongation	Charpy V-Notch
OK Autrod 13.62	Two Run. As Welded (acc. AWS) Plate thickness 12mm; Heat input 2.2 kJ/mm; Side1: 600A/32V/53cm /min; Side2: 700A/32V /60cm/min.; DC+	520 MPa	610 MPa	26 %	130 J @ 0 °C 70 J @ -51 °C
OK Autrod 13.64	Two Run. As Welded (acc. to AWS) Plate thickness 12mm Heat input 2.2kJ /mm 700A, 32V, 60cm /min DC+	550 MPa	650 MPa	26 %	70 J @ -51 °C

OK Flux 10.77

Agglomerated aluminate-basic flux for Submerged Arc Welding especially for production of mild and high-strength line pipe steels (mainly spiral pipe production). Shallow reinforcement, low transition angles, smooth surface finish even at high welding speeds. Designed for single and multi wire procedures. Suitable for DC and AC welding.

Specifications	
Classifications	EN ISO 14174 : S A AB 1 67 AC H5
Approvals	CE : EN 13479 UKCA : EN 13479

Approvals are based on factory location. Please contact ESAB for more information.

Diffusible Hydrogen	max 5 ml/100g weld metal (Redried flux)
Slag Type	Aluminate-basic
Alloy Transfer	Slightly Silicon and moderately Manganese alloying
Density	nom: 1.2 kg/dm ³
Basicity Index	nom: 1.3

Flux Consumption		
Volts	kg Flux / kg Wire DC+	kg Flux / kg Wire AC
26 V	0.7 kg	0.6 kg
30 V	1.0 kg	0.9 kg
34 V	1.3 kg	1.2 kg
38 V	1.6 kg	1.4 kg

Conditions : Dimension Ø 4.0 mm , Amps 580 A , Travel Speed 55 cm/min

Classifications	Wire	Weld Metal		
		EN - As Welded	AWS - As Welded	AWS - PWHT
OK Autrod 12.20	A5.17:EM12 14171-A:S2	14171-A: S 38 4 AB S2	A5.17: F7A4-EM12	A5.17: F6P4-EM12
OK Autrod 12.22	A5.17:EM12K 14171-A:S2Si	14171-A: S 38 4 AB S2Si	A5.17: F7A5-EM12K	A5.17: F6P5-EM12K
OK Autrod 12.24	A5.23:EA2 14171-A:S2Mo; 24598-A:S S Mo	14171-A: S 46 2 AB S2Mo	A5.23: F8A4-EA2-A2	A5.23: F7P2-EA2-A2
OK Autrod 12.34	A5.23:EA4 14171-A:S3Mo; 24598-A:S S MnMo	14171-A: S 50 3 AB S3Mo	A5.23: F8A4-EA4-A4	A5.23: F8P2-EA4-A4
OK Autrod 13.62	A5.23:EG 14171-A:SZ3TiB	-	A5.23: F8TA6-EG	-
OK Autrod 13.64	A5.23:EA2TiB 14171-A:S2MoTiB	-	A5.23: F8TA6-EA2TiB	-

Approvals	
Wire	CE
OK Autrod 12.20	•
OK Autrod 12.22	•
OK Autrod 12.24	•

Typical Weld Metal Analysis %			
C	Mn	Si	Mo
OK Autrod 12.20 AC, 580A, 29V			
0.07	1.3	0.2	-

OK Flux 10.77

Typical Weld Metal Analysis %

C	Mn	Si	Mo
OK Autrod 12.20 DC+, 580A, 29V			
0.06	1.4	0.3	-
OK Autrod 12.22 AC, 580A, 29V			
0.08	1.3	0.3	-
OK Autrod 12.22 DC+, 580A, 29V			
0.07	1.4	0.4	-
OK Autrod 12.24 AC, 580A, 29V			
0.07	1.3	0.3	0.5
OK Autrod 12.24 DC+, 580A, 29V			
0.07	1.3	0.3	0.5
OK Autrod 12.34 AC, 580A, 29V			
0.08	1.6	0.3	0.5
OK Autrod 12.34 DC+, 580A, 29V			
0.08	1.5	0.3	0.5

Typical Mechanical Properties

Wire	Condition	Yield Strength	Tensile Strength	Elongation	Charpy V-Notch
OK Autrod 12.20	As Welded EN AC	430 MPa	510 MPa	28 %	115 J @ -20 °C 95 J @ -30 °C 70 J @ -40 °C
OK Autrod 12.20	As Welded AWS DC+	420 MPa	500 MPa	28 %	80 J @ -20 °C 65 J @ -30 °C 55 J @ -40 °C
OK Autrod 12.20	Stress Relieved AWS DC+ (1.0 hour(s))	350 MPa	460 MPa	29 %	55 J @ -20 °C 45 J @ -30 °C 30 J @ -40 °C
OK Autrod 12.22	As Welded AWS DC+	420 MPa	520 MPa	26 %	130 J @ -20 °C 110 J @ -30 °C 80 J @ -40 °C 50 J @ -46 °C
OK Autrod 12.22	Stress Relieved AWS DC+ (1.0 hour(s))	350 MPa	460 MPa	28 %	130 J @ -20 °C 100 J @ -30 °C 70 J @ -40 °C 40 J @ -46 °C
OK Autrod 12.22	As Welded EN AC	430 MPa	520 MPa	28 %	155 J @ -20 °C 125 J @ -30 °C 80 J @ -40 °C 50 J @ -46 °C
OK Autrod 12.24	Stress Relieved AWS DC+ (1.0 hour(s))	450 MPa	550 MPa	25 %	80 J @ 0 °C 50 J @ -20 °C 40 J @ -29 °C 25 J @ -40 °C
OK Autrod 12.24	As Welded AWS DC+	495 MPa	580 MPa	25 %	90 J @ 0 °C 60 J @ -18 °C 60 J @ -20 °C 50 J @ -29 °C 40 J @ -40 °C
OK Autrod 12.24	As Welded EN AC	520 MPa	590 MPa	25 %	100 J @ 0 °C 80 J @ -20 °C 45 J @ -40 °C

OK Flux 10.77

Typical Mechanical Properties					
Wire	Condition	Yield Strength	Tensile Strength	Elongation	Charpy V-Notch
OK Autrod 12.34	As Welded AWS DC+	540 MPa	630 MPa	25 %	70 J @ -20 °C 60 J @ -29 °C 45 J @ -40 °C
OK Autrod 12.34	Stress Relieved AWS DC+ (1.0 hour(s))	490 MPa	590 MPa	25 %	60 J @ -20 °C 40 J @ -29 °C 25 J @ -40 °C
OK Autrod 12.34	As Welded EN AC	570 MPa	630 MPa	25 %	90 J @ -20 °C 70 J @ -30 °C 50 J @ -40 °C
OK Autrod 13.62	Two-Run. As Welded (acc. AWS) Plate thickness 12mm; Heat Input 2.2kJ/mm; Side 1 600A, 32V, 53cm/min; Side 2 700A, 32V, 60cm/min; DC+	510 MPa	600 MPa	25 %	150 J @ 0 °C 60 J @ -51 °C
OK Autrod 13.64	Two-Run. As Welded (acc. to AWS) Plate thickness 12mm Heat input 2.2kJ/mm 700A, 32V, 60cm/min DC+	550 MPa	650 MPa	24 %	60 J @ -51 °C

OK Flux 10.78

Agglomerated, aluminate-basic flux for Submerged Arc Welding. Very good surface finish and excellent slag detachability. Especially for concave horizontal fillet welds, as well for butt welds. High welding speeds. For general construction, beam fabrication, pressure vessels, pipe mills, transport industries, etc. Suitable for single and multi-wire procedures, for DC and AC. Due to the rather high Si-alloying intended for a limited number of passes and plate thickness up to about 25 mm.

Specifications

Classifications	EN ISO 14174 : S A AB 1 75 AC
Approvals	CE : EN 13479 UKCA : EN 13479

Approvals are based on factory location. Please contact ESAB for more information.

Slag Type	Aluminate-basic
Alloy Transfer	Moderately Si and no Mn alloying under EN ISO 14174 conditions. With DC+ slightly Mn alloying
Density	nom: 1.2 kg/dm ³
Basicity Index	nom: 0.8

Flux Consumption

Volts	kg Flux / kg Wire DC+	kg Flux / kg Wire AC
26 V	0.7 kg	0.6 kg
30 V	1 kg	0.9 kg
34 V	1.3 kg	1.2 kg
38 V	1.6 kg	1.4 kg

Conditions : Dimension Ø 4.0 mm , Amps 580 A , Travel Speed 55 cm/min

Classifications	Wire	Weld Metal		
		EN - As Welded	AWS - As Welded	AWS - PWHT
OK Autrod 12.22	A5.17:EM12K 14171-A:S2Si	14171-A: S 42 0 AB S2Si	A5.17: F7A0-EM12K	A5.17: F6P0-EM12K

Approvals

Wire	CE	UKCA
OK Autrod 12.22	•	•

Typical Weld Metal Analysis %

C	Mn	Si
OK Autrod 12.22 AC, 580A, 29V		
0.06	1.1	0.5
OK Autrod 12.22 DC+, 580A, 29V		
0.05	1.3	0.7

Typical Mechanical Properties

Wire	Condition	Yield Strength	Tensile Strength	Elongation	Charpy V-Notch
OK Autrod 12.22	As Welded AWS DC+	450 MPa	530 MPa	30 %	40 J @ -18 °C
OK Autrod 12.22	As Welded EN AC	480 MPa	570 MPa	28 %	70 J @ 0 °C
OK Autrod 12.22	Stress Relieved AWS DC+ (1 hour(s))	390 MPa	500 MPa	33 %	60 J @ -18 °C

OK Flux 10.79

Agglomerated, aluminate-basic flux for Submerged Arc Welding with high tolerance to rust & mill scale. Smooth surface finish and nice-looking welds also under severe plate surface conditions. Easy slag detachability. Primarily for horizontal fillet welds, also for butt welds. High welding speeds. For general construction, beam fabrication, pressure vessels, transport industries, etc. Suitable for DC and AC welding. Intended for a limited number of passes and plate thickness up to about 25 mm.

Specifications	
Classifications	EN ISO 14174 : S A AB 1 77 AC
Approvals	CE : EN 13479 UKCA : EN 13479

Approvals are based on factory location. Please contact ESAB for more information.

Slag Type	Aluminate-basic
Alloy Transfer	Moderately Silicon and Manganese alloying
Density	nom: 1.3 kg/dm ³
Basicity Index	nom: 1.0

Classifications	Wire	Weld Metal	
Wire	SFA/AWS - EN ISO	AWS - As Welded	AWS - PWHT
OK Autrod 12.22	A5.17:EM12K 14171-A:S2Si	A5.17: F7A2-EM12K	A5.17: F6P2-EM12K

Approvals		
Wire	CE	UKCA
OK Autrod 12.22	•	•

Typical Weld Metal Analysis %		
C	Mn	Si
OK Autrod 12.22 AC , 580A, 29V		
0.06	1.6	0.5
OK Autrod 12.22 DC+, 580A, 29V		
0.05	1.7	0.6

Typical Mechanical Properties					
Wire	Condition	Yield Strength	Tensile Strength	Elongation	Charpy V-Notch
OK Autrod 12.22	Stress Relieved AWS DC+ (1 hour(s))	390 MPa	490 MPa	33 %	100 J @ -18 °C 60 J @ -29 °C
OK Autrod 12.22	As Welded AWS DC+	440 MPa	520 MPa	30 %	80 J @ -18 °C 50 J @ -29 °C

OK Flux 10.81

Agglomerated, aluminate-rutile, low basicity flux for Submerged Arc Welding. Top-class surface finish and excellent slag detachability. High welding speeds. For pressure vessels, general construction, automotive, beam fabrication, low requirement pipeline steels, etc. Fine grained version especially for membrane wall panel fabrication. For butt welds and especially for concave horizontal fillet welds. Suitable for single and multi wire procedures, for DC and AC. Due to high Si-alloying intended for a limited number of passes and plate thickness up to about 25 mm.

Specifications	
Classifications	EN ISO 14174 : S A AR 1 97 AC
Approvals	CE : EN 13479 DB : 51.039.04 UKCA : EN 13479

Approvals are based on factory location. Please contact ESAB for more information.

Slag Type	Aluminate-rutile
Alloy Transfer	Very high Silicon and moderately Manganese alloying
Density	nom: 1.2 kg/dm ³
Basicity Index	nom: 0.6

Flux Consumption		
Volts	kg Flux / kg Wire DC+	kg Flux / kg Wire AC
26 V	0.7 kg	0.6 kg
30 V	1.0 kg	0.9 kg
34 V	1.3 kg	1.2 kg
38 V	1.6 kg	1.4 kg

Conditions : Dimension Ø 4.0 mm , Amps 580 A , Travel Speed 55 cm/min

Classifications	Wire	Weld Metal		
		EN - As Welded	AWS - As Welded	AWS - PWHT
OK Autrod 12.10	A5.17:EL12 14171-A:S1	14171-A: S 42 A AR S1	A5.17: F7AZ-EL12	A5.17: F7PZ-EL12
OK Autrod 12.20	A5.17:EM12 14171-A:S2	14171-A: S 46 0 AR S2	A5.17: F7A0-EM12	A5.17: F7PZ-EM12
OK Autrod 12.22	A5.17:EM12K 14171-A:S2Si	14171-A: S 50 A AR S2Si	A5.17: F7AZ-EM12K	A5.17: F7PZ-EM12K
OK Autrod 12.24	A5.23:EA2 14171-A:S2Mo; 24598-A:S S Mo	14171-A: S 50 A AR S2Mo	A5.23: F9AZ-EA2-A4	A5.23: F9PZ-EA2-A4
OK Autrod 12.30	14171-A:S3	14171-A: S 50 0 AR S3	-	-
OK Autrod 13.10 SC	A5.23:EB2R 24598-A:S S CrMo1	-	-	A5.23: F9PZ-EB2R-G
OK Autrod 13.36	A5.23:EG 14171-A:S2Ni1Cu	14171-A: S 50 A AR S2Ni1Cu	A5.23: F9A0-EG-G	-

Approvals									
Wire	ABS	BV	CE	DB	DNV	GL	LR	VdTÜV	
OK Autrod 12.10	-	-	•	•	-	-	-	•	
OK Autrod 12.20	•	•	•	•	•	•	•	•	
OK Autrod 12.22	-	-	•	-	-	-	-	-	
OK Autrod 12.24	-	-	-	-	-	-	-	•	
OK Autrod 12.30	-	-	•	•	-	-	-	•	
OK Autrod 13.10 SC	-	-	-	-	-	-	-	•	
OK Autrod 13.36	-	-	•	-	-	-	-	-	

OK Flux 10.81

Typical Weld Metal Analysis %								
C	Mn	Si	S	P	Ni	Cr	Mo	Cu
OK Autrod 12.10 DC+, 580A, 29V								
0.06	1.2	0.8	-	-	-	-	-	-
OK Autrod 12.10 AC, 580A, 29V								
0.07	1.1	0.7	-	-	-	-	-	-
OK Autrod 12.20 AC, 580A, 29V								
0.09	1.4	0.7	-	-	-	-	-	-
OK Autrod 12.20 DC+, 580A, 29V								
0.07	1.5	0.8	-	-	-	-	-	-
OK Autrod 12.22 AC, 580A, 29V								
0.09	1.4	0.8	-	-	-	-	-	-
OK Autrod 12.22 DC+, 580A, 29V								
0.07	1.5	0.9	-	-	-	-	-	-
OK Autrod 12.24 AC, 580A, 29V								
0.09	1.4	0.7	-	-	-	-	0.5	-
OK Autrod 12.24 DC+, 580A, 29V								
0.07	1.5	0.8	-	-	-	-	0.5	-
OK Autrod 12.30 AC, 580A, 29V								
0.10	1.7	0.6	-	-	-	-	-	-
OK Autrod 12.30 DC+, 580A, 29V								
0.08	1.75	0.7	-	-	-	-	-	-
OK Autrod 13.10 SC DC+, 575A, 29V								
0.06	1.4	0.9	0.010	0.020	-	1.0	0.5	-
OK Autrod 13.36 AC, 580A, 29V								
0.09	1.3	0.8	-	-	0.7	0.3	-	0.5
OK Autrod 13.36 DC+, 580A, 29V								
0.07	1.4	0.9	-	-	0.7	0.3	-	0.5

Typical Mechanical Properties					
Wire	Condition	Yield Strength	Tensile Strength	Elongation	Charpy V-Notch
OK Autrod 12.10	As Welded EN AC	450 MPa	530 MPa	25 %	80 J @ 20 °C 40 J @ 0 °C
OK Autrod 12.10	Stress Relieved AWS DC+ (1.0 hour(s))	420 MPa	520 MPa	27 %	45 J @ 20 °C 25 J @ 0 °C
OK Autrod 12.10	As Welded AWS DC+	450 MPa	540 MPa	25 %	50 J @ 20 °C 30 J @ 0 °C
OK Autrod 12.20	Stress Relieved AWS DC+ (1.0 hour(s))	440 MPa	550 MPa	25 %	50 J @ 20 °C 40 J @ 0 °C 20 J @ -18 °C
OK Autrod 12.20	As Welded AWS DC+	510 MPa	610 MPa	25 %	80 J @ 20 °C 60 J @ 0 °C 40 J @ -18 °C
OK Autrod 12.20	As Welded EN AC	500 MPa	570 MPa	30 %	90 J @ 20 °C 70 J @ 0 °C 50 J @ -18 °C
OK Autrod 12.22	As Welded AWS DC+	530 MPa	610 MPa	24 %	60 J @ 20 °C
OK Autrod 12.22	As Welded EN AC	550 MPa	640 MPa	20 %	70 J @ 20 °C
OK Autrod 12.22	Stress Relieved AWS DC+ (1.0 hour(s))	500 MPa	590 MPa	27 %	50 J @ 20 °C

OK Flux 10.81

Typical Mechanical Properties

Wire	Condition	Yield Strength	Tensile Strength	Elongation	Charpy V-Notch
OK Autrod 12.24	As Welded AWS DC+	565 MPa	660 MPa	23 %	65 J @ 20 °C 45 J @ 0 °C
OK Autrod 12.24	Stress Relieved AWS DC+ (1.0 hour(s))	555 MPa	650 MPa	22 %	55 J @ 20 °C 40 J @ 0 °C
OK Autrod 12.24	As Welded EN AC	650 MPa	715 MPa	24 %	80 J @ 20 °C 50 J @ 0 °C
OK Autrod 12.30	Stress Relieved EN DC+ (1.0 hour(s))	510 MPa	610 MPa	24 %	70 J @ 20 °C 50 J @ 0 °C
OK Autrod 12.30	As Welded EN DC+	550 MPa	640 MPa	25 %	80 J @ 20 °C 60 J @ 0 °C
OK Autrod 12.30	As Welded EN AC	550 MPa	620 MPa	25 %	100 J @ 20 °C 80 J @ 0 °C
OK Autrod 13.10 SC	PWHT PWHT 575A DC+ 29V (1 hour(s))	650 MPa	730 MPa	22 %	30 J @ 20 °C
OK Autrod 13.36	As Welded EN AC	610 MPa	680 MPa	25 %	80 J @ 20 °C 50 J @ 0 °C 40 J @ -20 °C
OK Autrod 13.36	As Welded AWS DC+	570 MPa	680 MPa	23 %	55 J @ 20 °C 40 J @ 0 °C 35 J @ -18 °C

OK Flux 10.83

Agglomerated, aluminate-rutile, low basicity flux for Submerged Arc Welding. High welding speeds. Smooth weld beads and excellent slag detachability. For general construction, membrane wall panels, beam fabrications, automotive (wheels), etc. Primarily used with single- or twin-arc wire systems. For DC and AC. For single pass butt welds, overlap welds and fillet welds at high speeds.

Specifications	
Classifications	EN ISO 14174 : S A AR 1 85 AC
Approvals	CE : EN 13479 UKCA : EN 13479

Approvals are based on factory location. Please contact ESAB for more information.

Slag Type	Aluminate-rutile
Alloy Transfer	High Silicon, no Manganese alloying
Density	nom: 1.2 kg/dm ³
Basicity Index	nom: 0.3

Flux Consumption		
Volts	kg Flux / kg Wire DC+	kg Flux / kg Wire AC
26 V	0.7 kg	0.6 kg
30 V	1.0 kg	0.9 kg
34 V	1.3 kg	1.2 kg
38 V	1.6 kg	1.4 kg

Conditions : Dimension Ø 4.0 mm , Amps 580 A , Travel Speed 55 cm/min

Classifications	Wire	Weld Metal		
Wire	SFA/AWS - EN ISO	EN - As Welded	AWS - As Welded	AWS - PWHT
OK Autrod 12.10	A5.17:EL12 14171-A:S1	14171-A: S 38 Z AR S1	A5.17: F7AZ-EL12	A5.17: F6PZ-EL12
OK Autrod 12.22	A5.17:EM12K 14171-A: S2Si	14171-A: S 42 Z AR S2Si	A5.17: F7AZ-EM12K	A5.17: F7PZ-EM12K

Approvals			
Wire	CE	VdTÜV	
OK Autrod 12.22	•	•	

Typical Weld Metal Analysis %		
C	Mn	Si
OK Autrod 12.10 DC+, 580A, 29V		
0.05	0.5	0.7
OK Autrod 12.10 AC, 580A, 29V		
0.05	0.6	0.7
OK Autrod 12.22 AC, 580A, 29V		
0.06	1.0	0.8
OK Autrod 12.22 DC+, 580A, 29V		
0.05	0.9	0.8

Typical Mechanical Properties					
Wire	Condition	Yield Strength	Tensile Strength	Elongation	Charpy V-Notch
OK Autrod 12.10	As Welded AWS DC+	440 MPa	520 MPa	30 %	30 J @ 20 °C
OK Autrod 12.10	As Welded EN AC	430 MPa	500 MPa	27 %	50 J @ 20 °C
OK Autrod 12.22	As Welded EN AC	470 MPa	550 MPa	26 %	70 J @ 20 °C 50 J @ 0 °C

OK Flux 10.83

Typical Mechanical Properties

Wire	Condition	Yield Strength	Tensile Strength	Elongation	Charpy V-Notch
OK Autrod 12.22	Stress Relieved AWS DC+	440 MPa	560 MPa	29 %	50 J @ 20 °C 20 J @ 0 °C
OK Autrod 12.22	As Welded AWS DC+	470 MPa	560 MPa	26 %	50 J @ 20 °C 30 J @ 0 °C



Stainless Steel

Welding Stainless Steels.....	4-6
STICK ELECTRODES (SMAW).....	4-9
OK 61.20.....	4-9
OK 61.25.....	4-10
OK 61.30.....	4-11
OK 61.35.....	4-12
OK 61.35 Cryo.....	4-13
OK 61.50.....	4-14
OK 61.80.....	4-15
OK 61.81.....	4-16
OK 61.85.....	4-17
OK 61.86.....	4-18
OK 63.20.....	4-19
OK 63.30.....	4-20
OK 63.34.....	4-22
OK 63.35.....	4-23
OK 63.41.....	4-24
OK 63.80.....	4-25
OK 63.85.....	4-26
OK 64.30.....	4-27
OK 67.13.....	4-28
OK 67.15.....	4-29
OK 67.43.....	4-30
OK 67.45.....	4-31
OK 67.50.....	4-32
OK 67.55.....	4-33
OK 67.60.....	4-34
OK 67.70.....	4-35
OK 67.75.....	4-37
OK 68.15.....	4-38
OK 68.17.....	4-39
OK 68.25.....	4-40
OK 68.53.....	4-41
OK 68.55.....	4-42
OK 68.81.....	4-43
OK 68.82.....	4-44
OK 69.25.....	4-45
OK 69.33.....	4-46
OK 310Mo-L.....	4-47
Exaton 22.9.3.LB.....	4-48
Exaton 22.9.3.LR.....	4-49
Exaton 22.12.HTR.....	4-50
Exaton 25.10.4.LB.....	4-51
Exaton 25.10.4.LR.....	4-52
Exaton 25.22.2.LMnB.....	4-53
Exaton 27.31.4.LCuR.....	4-54
MIG WIRES/TIG RODS (GMAW/GTAW).....	4-55
OK Autrod 16.95.....	4-55
OK Autrod 308H.....	4-56
OK Autrod 308L.....	4-57
OK Autrod 308LSi.....	4-58
OK Autrod 309L.....	4-60
OK Autrod 309LSi.....	4-61
OK Autrod 309MoL.....	4-62
OK Autrod 309Si.....	4-63
OK Autrod 310.....	4-64
OK Autrod 312.....	4-65
OK Autrod 316L.....	4-66
OK Autrod 316LMn.....	4-68
OK Autrod 316LSi.....	4-69

OK Autrod 317L	4-71
OK Autrod 318Si	4-72
OK Autrod 347	4-73
OK Autrod 347Si	4-75
OK Autrod 410NiMo	4-76
OK Autrod 430LNb	4-77
OK Autrod 430LNbTi	4-78
OK Autrod 2209	4-79
OK Autrod 2504	4-81
OK Autrod 2509	4-82
OK Tigrod 16.95	4-83
OK Tigrod 308H	4-84
OK Tigrod 308L	4-85
OK Tigrod 308LSi	4-86
OK Tigrod 309L	4-87
OK Tigrod 309LSi	4-88
OK Tigrod 309MoL	4-89
OK Tigrod 310	4-90
OK Tigrod 312	4-91
OK Tigrod 316L	4-92
OK Tigrod 316LSi	4-93
OK Tigrod 317L	4-94
OK Tigrod 318Si	4-95
OK Tigrod 347	4-96
OK Tigrod 347Si	4-97
OK Tigrod 410NiMo	4-98
OK Tigrod 430LNbTi	4-99
Exaton 19.9.L (GMAW)	4-100
Exaton 19.9.LSi (GMAW)	4-102
Exaton 19.12.3.L.CRYO (GMAW)	4-104
Exaton 19.12.3.LSiMo (GMAW)	4-106
Exaton 19.13.4.L (GMAW)	4-107
Exaton 20.25.5.LCu (GMAW)	4-108
Exaton 22.8.3.L (GMAW)	4-110
Exaton 22.8.3.LSi (GMAW)	4-112
Exaton 22.12.HT (GMAW)	4-114
Exaton 24.13.LHF (GMAW)	4-115
Exaton 24.13.LNb (GMAW)	4-116
Exaton 25.10.4.L (GMAW)	4-117
Exaton 25.20.L (GMAW)	4-119
Exaton 25.22.2.LMn (GMAW)	4-120
Exaton 27.7.5.L (GMAW)	4-122
Exaton 24.31.4.LCu (GMAW)	4-124
Exaton 29.8.2.L (GMAW)	4-126
Exaton AXT (GMAW)	4-128
Exaton SAFUREX (GMAW)	4-129
Exaton SX (GMAW)	4-130
Exaton 19.9.L (GTAW)	4-131
Exaton 19.9.LSi (GTAW)	4-132
Exaton 19.12.3.L.CRYO (GTAW)	4-133
Exaton 19.12.3.LSiMo (GTAW)	4-134
Exaton 19.13.4.L (GTAW)	4-135
Exaton 20.25.5.LCu (GTAW)	4-136
Exaton 22.8.3.L (GTAW)	4-137
Exaton 22.8.3.LSi (GTAW)	4-138
Exaton 22.12.HT (GTAW)	4-139
Exaton 24.13.LHF (GTAW)	4-140
Exaton 25.10.4.L (GTAW)	4-141
Exaton 25.20.L (GTAW)	4-142
Exaton 25.22.2.LMn (GTAW)	4-143
Exaton 27.7.5.L (GTAW)	4-144
Exaton 27.31.4.LCu (GTAW)	4-145

Exaton 29.8.2.L (GTAW)	4-146
Exaton SAFUREX (GTAW).....	4-147
Exaton SX (GTAW)	4-148
GAS-SHIELDED FLUX-CORED WIRES (FCAW/MCAW)	4-150
Arcaloy MC409Ti.....	4-150
Arcaloy MC439Ti.....	4-151
Filarc PZ6163	4-152
Filarc PZ6166	4-153
OK Tubrod 15.31	4-154
OK Tubrod 15.34.....	4-155
OK Tubrod 15.37.....	4-156
Shield-Bright 308H	4-157
Shield-Bright 308L	4-158
Shield-Bright 308L X-tra	4-160
Shield-Bright 309L.....	4-161
Shield-Bright 309L X-tra	4-163
Shield-Bright 316L.....	4-166
Shield-Bright 316L X-tra	4-168
Shield-Bright 347.....	4-169
Shield-Bright 2209.....	4-170
Shield-Bright 2594.....	4-172
SUBARC (SAW)	4-173
OK Autrod 16.97	4-173
OK Autrod 308H.....	4-174
OK Autrod 308L	4-175
OK Autrod 309L	4-176
OK Autrod 309MoL	4-177
OK Autrod 310	4-178
OK Autrod 316H.....	4-179
OK Autrod 316L	4-180
OK Autrod 316LMn	4-181
OK Autrod 317L	4-182
OK Autrod 318	4-183
OK Autrod 347	4-184
OK Autrod 410	4-185
OK Autrod 410NiMo	4-186
OK Autrod 430	4-187
Ok Autrod 2209.....	4-188
OK Autrod 2509	4-189
OK Flux 10.90	4-190
OK Flux 10.92	4-192
OK Flux 10.93	4-194
OK Flux 10.94	4-198
OK Flux 10.95	4-200
OK Flux 10.99	4-201
Exaton 19.9.L (SAW)	4-203
Exaton 19.12.3.L CRYO (SAW).....	4-204
Exaton 20.5.3.L (SAW)	4-205
Exaton 20.25.5.LCu (SAW).....	4-206
Exaton 22.8.3.L (SAW)	4-207
Exaton 22.12.HT (SAW).....	4-208
Exaton 24.13.LHF (SAW).....	4-209
Exaton 24.13.LNb (SAW).....	4-210
Exaton 25.10.4.L (SAW)	4-211
Exaton 25.20.L (SAW)	4-212
Exaton 25.22.2.LMn (SAW)	4-213
Exaton 27.31.4.LCu (SAW).....	4-214
Exaton 10SW	4-215
Exaton 15W.....	4-217

STRIP CLADDING (SAW/ESW)	4-220
OK Band 308L	4-220
OK Band 309L	4-221
OK Band 309L ESW	4-222
OK Band 309LMo ESW	4-223
OK Band 309LNb	4-224
OK Band 309LNb ESW	4-225
OK Band 316L	4-226
OK Band 347	4-227
OK Flux 10.05	4-228
OK Flux 10.10	4-230
OK Flux 10.14	4-232
OK Flux 10.26	4-233
Exaton 19.9.L (ESW)	4-234
Exaton 19.9.LNb (ESW)	4-235
Exaton 19.12.3.L (ESW)	4-236
Exaton 19.13.4.L (ESW)	4-237
Exaton 20.25.5.LCu (ESW)	4-238
Exaton 21.11.LNb (ESW)	4-239
Exaton 21.13.3.L (ESW)	4-240
Exaton 22.8.3.L (ESW)	4-241
Exaton 22.11.L (ESW)	4-242
Exaton 24.13.L (ESW)	4-243
Exaton 24.13.LNb (ESW)	4-244
Exaton 25.22.2.LMn (ESW)	4-245
Exaton 29.8.2.L (ESW)	4-246
Exaton 10SW	4-247
Exaton 31S	4-249
Exaton 37S	4-250
Exaton 47S	4-251
Exaton 48S	4-254
Exaton 49S	4-255

1. General

Stainless steels are materials that offer high resistance to corrosion. Depending on their composition and use, they can be anything from corrosion-resistant to acid-resistant.

The properties and microstructure of stainless steels are mainly influenced by different levels of chromium, nickel and/or molybdenum.

According to the type of microstructure in the delivery condition, stainless steels are classified into:

- Ferritic
- Martensitic
- Ferritic-Austenitic (Duplex Steels)
- Austenitic

In particular, they also vary in terms of their suitability for welding.

2. Universal Guidelines on Welding for All Stainless Steels

Joint Preparation

When welding stainless steels, the cleanliness of the weld surfaces and the weld surroundings is of crucial importance. Contaminants such as scale, oil, grease, and paint, etc. must always be removed before welding.

After every welding pass, any end craters, arc strikes or raised weld beads should be carefully ground down so that the subsequent beads can be applied without welding defects. To avoid pores, TIG or MIG root layers should also be ground.

“Burn marks” caused by arcing next to the welding seam or due to a poor earth connection must also be avoided. At arcing burn marks, overheating can cause tiny cracks to appear, which can lead to crevice corrosion.

Austenitic stainless steels have a high rate of thermal expansion. In order to counter excessive bending whilst being welded, jigs and tack welding are recommended. The maximum tack spacing should not exceed 100 mm with a tack length of about 30 - 40 mm.

Post-Weld Treatment of the Welding Joint

For all stainless steels, surface treatment of the weld bead and the heat-affected zone is required after welding. The aim of the post-weld treatment is to create a metallicly bright surface on which the passive layer required for corrosion resistance can form. The treatment can be done either mechanically by grinding, brushing, polishing or chemically by pickling.

Steels with approx. 13% Cr require a finely ground or polished surface to achieve the highest corrosion resistance.

When carrying out mechanical post-weld treatment, it must be ensured that tools specifically designed for processing stainless steel (brushes, grinding discs, etc.) are used.

Excessive heating of the component, e.g. due to excessive contact pressure of the grinding disc, must be avoided during grinding. If austenitic steels need to be polished, unstabilised grades (without Ti or Nb) should be selected; this also applies to welding consumables.

The formation of the passive layer can be accelerated by final treatment of the weld zone with 5 - 20 % nitric acid or pickling.

3. Ferritic chromium steels

Typical representatives: X6Cr13; X6Cr17

Features

- Alloyed with 12 - 30 % chromium; max. C content: 0.10 %
- Similar strength characteristics to unalloyed steels
- High scale resistance up to max. 1100°C
- High resistance to sulphurous ambient air

Welding Instructions

The suitability of ferritic chromium steels for welding is affected by their tendency to form coarse grains that harden due to the formation of martensite during the welding process.

Possible consequences include a decrease in mechanical properties and a tendency for cold cracking in the area around the weld. However, these risks can be largely avoided by selecting suitable welding consumables and adapting welding technology.

Suitable Welding Consumables

- Austenitic consumables of type 19 9 L / 19 9 Nb
- Consumables of the same type in the capping run, if sulphurous media pose a corrosion hazard, especially for heat-resistant chromium steels (sulphurous furnace atmosphere).

Welding Procedure

Re-drying:	Required for covered (stick) electrodes (SMAW) without VacPac and fluxes
Preheating and interpass temperature:	150 – 250°C. For low metal thicknesses (max. 3 mm) and chromium steels with a C content of < 0.08%, preheating can be omitted.
Post-weld heat treatment:	Annealing at approx. 700 – 750°C
Heat management:	Weld with as little heat input as possible to minimise distortion and embrittlement in the HAZ.

4. Martensitic Chromium Steels

Typical representatives: X20Cr13; X30Cr13

Features

- Alloyed with 12 - 18 % chromium; c content: 0.1 - 1.0 %
- Heat treatable
- Hard and brittle due to high martensite content
- Poorer corrosion properties than ferritic chromium steels

Welding Instructions

Martensitic chromium steels have poor weldability due to their high carbon content. The risk of cold cracking after welding is even higher than with ferritic chromium steels.

Suitable Welding Consumables

- Austenitic consumables of type 19 9 L / 19 9 Nb for steels with a maximum C content of 0.2 %
- Nickel-based consumables of type Ni 6182 or Ni 6082 for steels with a C content higher than 0.2%

Welding Procedure

If welding is unavoidable, preheating to 300 – 400°C should always be carried out. The heat input should be higher than with ferritic chromium steels. The post-weld heat treatment should be carried out in the form of stress-relief annealing at 650 - 750°C.

5. Ferritic-Austenitic Steels (Duplex)

See section - *Information on Welding Ferrite-Austenite Steels (Duplex/Lean and Super Duplex)*.

6. Austenitic Stainless Steels

Typical representatives:	X5CrNi18-10
	X5CrNiMo17-12-2
	X2CrNiMo18-15-4
	X6CrNiMoTi17-12-2

Features

- Conversion-free structure, no risk of hardening
- High rust and acid resistance
- Cold-resistant and insensitive to brittle fracture, can also be used at low temperatures
- Low thermal conductivity
- High thermal expansion coefficient

Welding Instructions

The austenitic stainless steels have very good weldability. There is no danger of coarse grain formation or cold cracking. However, the effect of welding heat can lead to chromium carbide precipitation. In non-stabilised steels with a C content of more than 0.07%, these carbides can lead to intergranular corrosion. Welding consumables with low carbon content or Nb-stabilised types can be a good solution.

Another problem is the tendency of austenitic stainless steels to hot crack. It is caused by impurities, particularly sulphur, which is enriched at the centre of the weld bead when the weld metal solidifies. Impurities such as sulphur lower the melting point of the last solidified areas in the weld.

If the internal stresses formed during cooling exceed the strength level of the last solidified areas, cracking will occur. This reduces the strength of the weld bead and is the reason why cracking occurs.

A sufficient delta ferrite content of 4 – 10 % in the weld metal reduces the risk of hot cracking. High manganese content in welding consumables achieves a similar effect by binding the sulphur.

Suitable Welding Consumables

- Austenitic consumables of the same or similar type
- In the event of corrosion from nitric acid, the use of similar welding consumables (without molybdenum) has proven to be effective for CrNi steels
- For Nb- or Ti-stabilised parent materials, Nb-stabilised austenitic additives are required if the operating temperature is between 350 - 400°C.

Welding Procedure

In general, neither preheating nor post-heat treatment is required for welding austenitic stainless steels. In fact, the aim should be to achieve the lowest possible heat input during the welding process in order to minimise shrinkage, the risk of shrinkage cracks and possible precipitates. Suitable welding techniques include using stringer beads.

Welding should be carried out with a short arc if possible in order to avoid the absorption of large amounts of nitrogen into the weld metal (risk of hot cracking due to primary austenite solidification).

For further information on welding stainless steels, refer to:

EN 1011-3:

Welding - Recommendations for welding metallic materials - Part 3: Arc welding of stainless steels

OK 61.20



Rutile coated electrode for welding 19Cr10Ni -type steels. Also suitable for welding stabilized steels of similar composition, except when the full creep resistance of the base material is to be met. The electrode is especially designed for welding of thin walled pipes. It can be used in all positions including vertical down.

Specifications	
Classifications	EN ISO 3581-A : E 19 9 L R 1 1 SFA/AWS A5.4 : E308L-16 Werkstoffnummer : 1.4316
Approvals	CE : EN 13479 UKCA : EN 13479 VdTUV : 10769

Approvals are based on factory location. Please contact ESAB for more information.

Welding Current	DC+, AC
Ferrite Content	FN 3 - 10
Alloy Type	Austenitic CrNi
Coating Type	Acid Rutile
Min AC OCV	50

Typical Tensile Properties			
Condition	Yield Strength	Tensile Strength	Elongation
ISO			
As Welded	430 MPa	560 MPa	45 %

Typical Charpy V-Notch Properties		
Condition	Testing Temperature	Impact Value
ISO		
As Welded	20 °C	70 J
As Welded	-50 °C	48 J
As Welded	-60 °C	38 J

Typical Weld Metal Analysis %							
C	Mn	Si	Ni	Cr	Cu	N	FN WRC-92
0.026	0.7	0.7	9.6	19.2	0.05	0.10	5

Deposition Data					
Diameter	Current	Voltage	Efficiency (%)	Fusion time per electrode at 90% I max	Deposition Rate
2.0 x 300 mm	25-60 A	22 V	66 %	38 sec	0.7 kg/h
2.5 x 300 mm	28-85 A	22 V	63 %	44 sec	0.9 kg/h

OK 61.25



Basic coated stainless electrode of the 308H-type especially designed for high temperature applications.

Specifications

Classifications	EN ISO 3581-A : E 19 9 H B 2 2 SFA/AWS A5.4 : E308H-15
Welding Current	DC+
Ferrite Content	FN 2-5
Alloy Type	Austenitic CrNi
Coating Type	Basic

Typical Tensile Properties

Condition	Yield Strength	Tensile Strength	Elongation
AWS			
As Welded	430 MPa	600 MPa	45 %
PWHT 1000 hour(s) 720 °C	300 MPa	570 MPa	45 %

Typical Charpy V-Notch Properties

Condition	Testing Temperature	Impact Value
AWS		
As Welded	20 °C	95 J
PWHT 1000 hour(s) 720 °C	20 °C	100 J
As Welded	-18 °C	83 J
As Welded	-40 °C	67 J

Typical Weld Metal Analysis %

C	Mn	Si	Ni	Cr	N	FN WRC-92
0.06	1.7	0.3	9.8	18.8	0.06	4

Deposition Data

Diameter	Current	Voltage	Efficiency (%)	Fusion time per electrode at 90% I max	Deposition Rate
2.5 x 300 mm	55-85 A	23 V	62 %	47 sec	0.9 kg/h
3.2 x 350 mm	75-110 A	23 V	59 %	66 sec	1.2 kg/h
4.0 x 350 mm	80-160 A	24 V	61 %	68 sec	1.8 kg/h

OK 61.30



Extra low carbon stainless steel electrode for welding steels of the 19 Cr 10 Ni-type. Also suitable for welding stabilized stainless steels of similar composition, except when the full creep resistance of the base material is to be met.

Specifications	
Classifications	EN ISO 3581-A : E 19 9 L R 1 2 SFA/AWS A5.4 : E308L-17 CSA W48 : E308L-17 Werkstoffnummer : 1.4316
Approvals	ABS : Stainless CE : EN 13479 CWB : E308L-17 DB : 30.039.02 DNV-GL : VL 308 L UKCA : EN 13479 VdTUV : 00792

Approvals are based on factory location. Please contact ESAB for more information.

Welding Current	DC+, AC
Ferrite Content	FN 3-10
Alloy Type	Austenitic CrNi
Coating Type	Acid Rutile
Min AC OCV	50

Typical Tensile Properties			
Condition	Yield Strength	Tensile Strength	Elongation
ISO			
As Welded	430 MPa	580 MPa	45 %

Typical Charpy V-Notch Properties		
Condition	Testing Temperature	Impact Value
ISO		
As Welded	20 °C	70 J
As Welded	-60 °C	49 J

Typical Weld Metal Analysis %						
C	Mn	Si	Ni	Cr	N	FN WRC-92
0.03	0.7	0.9	10.0	19.3	0.09	5

Deposition Data					
Diameter	Current	Voltage	Efficiency (%)	Fusion time per electrode at 90% I max	Deposition Rate
1.6 x 300 mm	35-45 A	27 V	55 %	24 sec	0.6 kg/h
2.0 x 300 mm	35-65 A	29 V	55 %	29 sec	0.8 kg/h
2.5 x 300 mm	50-90 A	31 V	55 %	36 sec	1.1 kg/h
3.2 x 350 mm	70-130 A	31 V	60 %	54 sec	1.4 kg/h
4.0 x 350 mm	90-180 A	32 V	60 %	60 sec	2.0 kg/h
5.0 x 350 mm	140-250 A	33 V	60 %	60 sec	3.0 kg/h

OK 61.35



Basic stainless electrode of the 308L-type designed for positional welding such as piping. Suitable for applications where requirements concerning mechanical properties are demanding. Lateral expansion of min. 0.38 mm is met down to -120 °C.

Specifications	
Classifications	EN ISO 3581-A : E 19 9 L B 2 2 SFA/AWS A5.4 : E308L-15 Werkstoffnummer : 1.4316
Approvals	CE : EN 13479 DB : 30.039.08 UKCA : EN 13479 VdTÜV : 04811

Approvals are based on factory location. Please contact ESAB for more information.

Welding Current	DC+
Ferrite Content	FN 4-8
Alloy Type	Austenitic CrNi
Coating Type	Basic

Typical Tensile Properties			
Condition	Yield Strength	Tensile Strength	Elongation
AWS			
As Welded	445 MPa	610 MPa	44 %

Typical Charpy V-Notch Properties		
Condition	Testing Temperature	Impact Value
AWS		
As Welded	-196 °C	40 J
ISO		
As Welded	20 °C	100 J
As Welded	-120 °C	70 J
As Welded	-196 °C	40 J

Typical Weld Metal Analysis %						
C	Mn	Si	Ni	Cr	N	FN WRC-92
0.04	1.6	0.3	9.8	19.5	0.06	6

Deposition Data					
Diameter	Current	Voltage	Efficiency (%)	Fusion time per electrode at 90% I max	Deposition Rate
2.5 x 300 mm	55-85 A	22 V	61 %	37 sec	0.9 kg/h
3.2 x 350 mm	80-120 A	25 V	61 %	54 sec	1.3 kg/h
4.0 x 350 mm	80-180 A	27 V	61 %	58 sec	1.9 kg/h

OK 61.35 Cryo



A basic stainless stick electrode of the 308L-type especially designed for cryogenic applications. Provides controlled low ferrite content to ensure lateral expansion of min. 0.38 mm at -196 °C.

Specifications	
Classifications	EN ISO 3581-A : E 19 9 L B 2 2 SFA/AWS A5.4 : E308L-15 Werkstoffnummer : 1.4316
Approvals	VdTÜV : 10721

Approvals are based on factory location. Please contact ESAB for more information.

Welding Current	DC+
Ferrite Content	FN 2-4
Alloy Type	Austenitic CrNi
Coating Type	Basic

Typical Tensile Properties			
Condition	Yield Strength	Tensile Strength	Elongation
AWS			
As Welded	425 MPa	580 MPa	45 %

Typical Charpy V-Notch Properties		
Condition	Testing Temperature	Impact Value
AWS		
As Welded	20 °C	100 J
As Welded	-196 °C	43 J
ISO		
As Welded	-196 °C	43 J

Typical Weld Metal Analysis %						
C	Mn	Si	Ni	Cr	N	FN WRC-92
0.04	1.6	0.3	10.5	18.7	0.06	3

Deposition Data					
Diameter	Current	Voltage	Efficiency (%)	Fusion time per electrode at 90% I max	Deposition Rate
2.5 x 300 mm	55-85 A	22 V	61 %	37 sec	0.9 kg/h
3.2 x 350 mm	80-120 A	25 V	61 %	54 sec	1.3 kg/h
4.0 x 350 mm	80-180 A	27 V	61 %	58 sec	1.9 kg/h
5.0 x 350 mm	160-210 A	26 V	58 %	70 sec	2.3 kg/h

OK 61.50



OK 61.50 is a stainless steel electrode for welding of 19Cr 9 Ni austenitic stainless steels with a carbon content >0.04%. Especially designed for high temperature applications.

Specifications

Classifications	EN ISO 3581-A : E 19 9 H R 1 2 SFA/AWS A5.4 : E308H-17
Welding Current	DC+, AC
Ferrite Content	FN 3 - 8
Alloy Type	Austenitic CrNi
Coating Type	Acid Rutile
Min AC OCV	55

Typical Tensile Properties

Condition	Yield Strength	Tensile Strength	Elongation
AWS			
As Welded	430 MPa	600 MPa	45 %

Typical Charpy V-Notch Properties

Condition	Testing Temperature	Impact Value
AWS		
As Welded	20 °C	60 J

Typical Weld Metal Analysis %

C	Mn	Si	Ni	Cr	N	FN WRC-92
0.05	0.7	0.7	10.0	19.8	0.10	4

Deposition Data

Diameter	Current	Voltage	Efficiency (%)	Fusion time per electrode at 90° I max	Deposition Rate
2.5 x 300 mm	50-85 A	27 V	56 %	42 sec	0.9 kg/h
3.2 x 350 mm	70-110 A	27 V	56 %	63 sec	1.1 kg/h
4.0 x 350 mm	110-165 A	28 V	56 %	62 sec	1.7 kg/h

OK 61.80



Nb-stabilized MMA-electrode for welding Nb- or Ti-stabilized stainless steel of the 19Cr10Ni-type. The hotcracking resistance is quite good. The ferrite in the weld metal may transform to brittle phases at elevated temperatures. To avoid excessive embrittlement of the welds the maximum working temperature is limited to 400° C.

Specifications	
Classifications	EN ISO 3581-A : E 19 9 Nb R 1 2 SFA/AWS A5.4 : E347-17
Approvals	CE : EN 13479 DNV-GL : VL 347 UKCA : EN 13479 VdTUV : 00638

Approvals are based on factory location. Please contact ESAB for more information.

Welding Current	DC+, AC
Ferrite Content	FN 6-12
Alloy Type	Austenitic CrNi
Coating Type	Acid Rutile
Min AC OCV	50

Typical Tensile Properties			
Condition	Yield Strength	Tensile Strength	Elongation
ISO			
As Welded	480 MPa	620 MPa	40 %

Typical Charpy V-Notch Properties		
Condition	Testing Temperature	Impact Value
ISO		
As Welded	20 °C	60 J
As Welded	0 °C	58 J
As Welded	-60 °C	40 J

Typical Weld Metal Analysis %							
C	Mn	Si	Ni	Cr	N	Nb	FN WRC-92
0.03	0.6	0.7	10.0	19.5	0.09	0.29	7

Deposition Data					
Diameter	Current	Voltage	Efficiency (%)	Fusion time per electrode at 90% I max	Deposition Rate
2.5 x 300 mm	50-90 A	26 V	56 %	38 sec	1.0 kg/h
3.2 x 350 mm	70-130 A	28 V	56 %	53 sec	1.4 kg/h
4.0 x 350 mm	90-180 A	30 V	56 %	55 sec	2.0 kg/h
5.0 x 350 mm	140-250 A	31 V	56 %	60 sec	2.9 kg/h

OK 61.81



Nb-stabilized MMA-electrode for welding Nb- or Ti-stabilized stainless steel of the 19Cr10Ni-type. OK 61.81 has a better hot cracking resistance compared with OK 61.80. Owing to the quite high ferrite content level, the working temperature should be limited to maximum 400°C.

Specifications

Classifications	EN ISO 3581-A : E 19 9 Nb R 3 2 SFA/AWS A5.4 : E347-16 Werkstoffnummer : 1.4551
Approvals	CE : EN 13479 DNV-GL : VL 347 UKCA : EN 13479

Approvals are based on factory location. Please contact ESAB for more information.

Welding Current	DC+, AC
Ferrite Content	FN 6-12
Alloy Type	Austenitic CrNi
Coating Type	Rutile
Min AC OCV	60

Typical Tensile Properties

Condition	Yield Strength	Tensile Strength	Elongation
AWS			
As Welded	560 MPa	700 MPa	31 %
ISO			
As Welded	550 MPa	700 MPa	-

Typical Charpy V-Notch Properties

Condition	Testing Temperature	Impact Value
AWS		
As Welded	20 °C	60 J
ISO		
As Welded	-10 °C	71 J

Typical Weld Metal Analysis %

C	Mn	Si	Ni	Cr	N	Nb	FN WRC-92
0.06	1.7	0.7	9.7	20.2	0.08	0.72	7

Deposition Data

Diameter	Current	Voltage	Efficiency (%)	Fusion time per electrode at 90% I max	Deposition Rate
2.5 x 300 mm	50-80 A	29 V	59 %	36 sec	1.2 kg/h
3.2 x 350 mm	75-115 A	23 V	60 %	66 sec	1.2 kg/h
4.0 x 350 mm	80-160 A	24 V	60 %	66 sec	1.7 kg/h
5.0 x 350 mm	140-210 A	25 V	60 %	78 sec	2.3 kg/h

OK 61.85



Nb-stabilized basic coated electrode designed for welding of Nb- or Ti-stabilized stainless steels of the 19Cr10Ni-type. OK 61.85 provides the best hot cracking resistance of the products belonging to the 347 range. Due to the relatively high ferrite content level, the maximum working temperature should be limited to 400 °C.

Specifications	
Classifications	EN ISO 3581-A : E 19 9 Nb B 2 2 SFA/AWS A5.4 : E347-15 Werkstoffnummer : 1.4551
Approvals	VdTÜV : 05663

Approvals are based on factory location. Please contact ESAB for more information.

Welding Current	DC+
Ferrite Content	FN 6-12
Alloy Type	Austenitic CrNi
Coating Type	Basic

Typical Tensile Properties			
Condition	Yield Strength	Tensile Strength	Elongation
ISO			
As Welded	500 MPa	620 MPa	40 %
Stress Relieved 16 hour(s) 600 °C	500 MPa	640 MPa	40 %

Typical Charpy V-Notch Properties		
Condition	Testing Temperature	Impact Value
ISO		
As Welded	20 °C	100 J
Stress Relieved 16 hour(s) 600 °C	20 °C	80 J
As Welded	-60 °C	70 J
Stress Relieved 16 hour(s) 600 °C	-60 °C	40 J

Typical Weld Metal Analysis %							
C	Mn	Si	Ni	Cr	N	Nb	FN WRC-92
0.04	1.7	0.4	10.2	19.5	0.07	0.61	8

Deposition Data					
Diameter	Current	Voltage	Efficiency (%)	Fusion time per electrode at 90° I max	Deposition Rate
2.5 x 300 mm	55-80 A	25 V	60 %	42 sec	0.9 kg/h
3.2 x 350 mm	75-110 A	23 V	62 %	64 sec	1.2 kg/h
4.0 x 350 mm	80-150 A	24 V	61 %	70 sec	1.6 kg/h
5.0 x 350 mm	150-200 A	23 V	61 %	76 sec	2.3 kg/h

OK 61.86



Niobium stabilized stainless steel electrode for welding niobium or titanium stabilized steels of the 19Cr 10Ni-type. Specially designed for use in applications where heat treatment is required. OK 61.86 can be a bit sensitive for hot cracking, so issued welding procedures should be followed carefully. Despite the low ferrite content level, the maximum working temperature should be limited to maximum 400°C. It will not match the creep resistance of base materials that are designed to work at higher temperatures.

Specifications

Classifications	EN ISO 3581-A : E 19 9 Nb R 1 2 SFA/AWS A5.4 : E347-17 Werkstoffnummer : 1.4551
------------------------	---

Welding Current	AC, DC+
Ferrite Content	FN 4-8
Alloy Type	Austenitic CrNi
Min AC OCV	50

Typical Tensile Properties

Condition	Yield Strength	Tensile Strength	Elongation
ISO			
As Welded	520 MPa	660 MPa	35 %

Typical Charpy V-Notch Properties

Condition	Testing Temperature	Impact Value
ISO		
As Welded	20 °C	55 J

Typical Weld Metal Analysis %

C	Mn	Si	Ni	Cr	N	Nb	FN WRC-92
0.025	0.7	0.8	10.4	19.0	0.09	0.35	5

Deposition Data

Diameter	Current	Voltage	Efficiency (%)	Fusion time per electrode at 90° l max	Deposition Rate
3.2 x 350 mm	70-120 A	27 V	55 %	62 sec	1.1 kg/h
4.0 x 350 mm	80-170 A	28 V	54 %	64 sec	1.7 kg/h

OK 63.20



Rutile coated electrode for welding 18Cr12Ni3Mo -type steels. Also suitable for welding stabilized steels of similar composition. The electrode is especially designed for welding of thin walled pipes. Diameters 1.6 - 2.5mm. It can be used in all positions including vertical down.

Specifications	
Classifications	EN ISO 3581-A : E 19 12 3 L R 1 1 SFA/AWS A5.4 : E316L-16 CSA W48 : E316L-16 Werkstoffnummer : 1.4430
Approvals	CE : EN 13479 CWB : E316L-16 UKCA : EN 13479 VdTUV : 09716

Approvals are based on factory location. Please contact ESAB for more information.

Welding Current	DC+, AC
Ferrite Content	FN 3-10
Alloy Type	Austenitic CrNiMo
Coating Type	Acid Rutile
Min AC OCV	50

Typical Tensile Properties			
Condition	Yield Strength	Tensile Strength	Elongation
ISO			
As Welded	480 MPa	590 MPa	41 %

Typical Charpy V-Notch Properties		
Condition	Testing Temperature	Impact Value
ISO		
As Welded	20 °C	56 J
As Welded	-60 °C	46 J

Typical Weld Metal Analysis %							
C	Mn	Si	Ni	Cr	Mo	N	FN WRC-92
0.02	0.7	0.7	12.1	18.4	2.8	0.11	4

Deposition Data					
Diameter	Current	Voltage	Efficiency (%)	Fusion time per electrode at 90% I max	Deposition Rate
1.6 x 300 mm	15-40 A	23 V	63 %	53 sec	0.3 kg/h
2.0 x 300 mm	18-60 A	25 V	62 %	49 sec	0.5 kg/h
2.5 x 300 mm	25-80 A	22 V	63 %	54 sec	0.8 kg/h
3.2 x 350 mm	55-110 A	26 V	60 %	65 sec	1.2 kg/h

OK 63.30



Extra low carbon stainless steel electrode for welding steels of the 18Cr 12Ni 2.8Mo-type. Also suitable for welding of stabilized stainless steels of similar composition, except when the full creep resistance of the base metal is to be met.

Specifications	
Classifications	EN ISO 3581-A : E 19 12 3 L R 1 2 SFA/AWS A5.4 : E316L-17 CSA W48 : E316L-17 Werkstoffnummer : 1.4430
Approvals	ABS : E316L-17 BV : 316L CE : EN 13479 CWB : E316L-17 DB : 30.039.06 DNV-GL : VL 316 L LR : 316L UKCA : EN 13479 VdTÜV : 00262

Approvals are based on factory location. Please contact ESAB for more information.

Welding Current	DC+, AC
Ferrite Content	FN 3-10
Alloy Type	Austenitic CrNiMo
Coating Type	Acid Rutile
Min AC OCV	50

Typical Tensile Properties			
Condition	Yield Strength	Tensile Strength	Elongation
ISO			
As Welded	460 MPa	570 MPa	40 %

Typical Charpy V-Notch Properties		
Condition	Testing Temperature	Impact Value
ISO		
As Welded	20 °C	60 J
As Welded	-20 °C	55 J
As Welded	-60 °C	43 J

Typical Weld Metal Analysis %							
C	Mn	Si	Ni	Cr	Mo	N	FN WRC-92
0.02	0.6	0.8	11.0	18.1	2.6	0.10	6

Deposition Data					
Diameter	Current	Voltage	Efficiency (%)	Fusion time per electrode at 90% I max	Deposition Rate
1.6 x 300 mm	30-45 A	29 V	56 %	37 sec	0.4 kg/h
2.0 x 300 mm	45-65 A	29 V	60 %	39 sec	0.6 kg/h
2.5 x 300 mm	45-90 A	29 V	55 %	45 sec	0.9 kg/h
3.2 x 350 mm	60-125 A	30 V	55 %	57 sec	1.4 kg/h

OK 63.30

Deposition Data

Diameter	Current	Voltage	Efficiency (%)	Fusion time per electrode at 90% I max	Deposition Rate
4.0 x 350 mm	70-190 A	32 V	56 %	57 sec	2.0 kg/h
5.0 x 350 mm	100-280 A	32 V	56 %	63 sec	3.0 kg/h

OK 63.34



OK 63.34 is a rutile MMA-electrode of the 19Cr 12Ni 3Mo-type designed for vertical down welding of steels of similar composition. It provides beads with a very good finish and good tie in profiles to the joint edges.

Specifications	
Classifications	EN ISO 3581-A : E 19 12 3 L R 1 1 SFA/AWS A5.4 : E316L-16 CSA W48 : E316L-16 Werkstoffnummer : 1.4430
Approvals	CWB : E316L-16 VdTÜV : 03816

Approvals are based on factory location. Please contact ESAB for more information.

Welding Current	DC+, AC
Ferrite Content	FN 3-8
Alloy Type	Austenitic CrNiMo
Coating Type	Acid Rutile
Min AC OCV	60

Typical Tensile Properties			
Condition	Yield Strength	Tensile Strength	Elongation
AWS			
As Welded	440 MPa	600 MPa	40 %
ISO			
As Welded	440 MPa	600 MPa	-

Typical Charpy V-Notch Properties		
Condition	Testing Temperature	Impact Value
AWS		
As Welded	20 °C	65 J
As Welded	-20 °C	52 J
ISO		
As Welded	20 °C	65 J
As Welded	-120 °C	38 J

Typical Weld Metal Analysis %							
C	Mn	Si	Ni	Cr	Mo	N	Ferrite FN
0.02	0.8	0.8	11.8	18.7	2.8	0.13	6

Deposition Data					
Diameter	Current	Voltage	Efficiency (%)	Fusion time per electrode at 90% I max	Deposition Rate
2.5 x 300 mm	70-90 A	22 V	70 %	39 sec	1.0 kg/h
3.2 x 300 mm	80-130 A	25 V	70 %	39 sec	1.6 kg/h

OK 63.35



OK 63.35 is a low carbon stainless steel electrode with basic coating of the 18Cr12Ni3Mo type. It is suitable for applications where the mechanical requirements are tough. It provides good impact toughness levels. Minimum lateral expansion of 0.38mm requirement is met down to -120°C. The same requirement can be met at -196°C when the ferrite content is at the low end of the specification i.e. FN 3 - 4.

Specifications	
Classifications	EN ISO 3581-A : E 19 12 3 L B 2 2 SFA/AWS A5.4 : E316L-15 Werkstoffnummer : 1.4430
Approvals	ABS : Stainless CE : EN 13479 UKCA : EN 13479 VdTÜV : 04812

Approvals are based on factory location. Please contact ESAB for more information.

Welding Current	DC+
Ferrite Content	FN 3-8
Alloy Type	Austenitic CrNi
Coating Type	Basic

Typical Tensile Properties			
Condition	Yield Strength	Tensile Strength	Elongation
AWS			
As Welded	430 MPa	560 MPa	40 %

Typical Charpy V-Notch Properties		
Condition	Testing Temperature	Impact Value
AWS		
As Welded	20 °C	95 J
As Welded	-60 °C	75 J
As Welded	-120 °C	60 J
As Welded	-196 °C	35 J

Typical Weld Metal Analysis %							
C	Mn	Si	Ni	Cr	Mo	N	FN WRC-92
0.04	1.6	0.4	12.6	18.3	2.7	0.06	4

Deposition Data					
Diameter	Current	Voltage	Efficiency (%)	Fusion time per electrode at 90% I max	Deposition Rate
2.5 x 300 mm	55-85 A	24 V	63 %	42 sec	0.9 kg/h
3.2 x 350 mm	80-120 A	24 V	63 %	58 sec	1.3 kg/h
4.0 x 350 mm	80-180 A	24 V	62 %	63 sec	1.8 kg/h

OK 63.41



High-efficiency low carbon stainless steel electrode for welding steels of the type 18 Cr 12 Ni 2-3 Mo.

Specifications

Classifications	EN ISO 3581-A : E 19 12 3 L R 5 3 SFA/AWS A5.4 : E316L-26 Werkstoffnummer : 1.4430
Approvals	CE : EN 13479 DNV-GL : VL 316 L LR : 316LN UKCA : EN 13479 VdTÜV : 01014

Approvals are based on factory location. Please contact ESAB for more information.

Welding Current	AC, DC+
Ferrite Content	FN 3-8
Alloy Type	Austenitic CrNi
Coating Type	Acid Rutile
Min AC OCV	55

Typical Tensile Properties

Condition	Yield Strength	Tensile Strength	Elongation
ISO			
As Welded	470 MPa	570 MPa	35 %

Typical Charpy V-Notch Properties

Condition	Testing Temperature	Impact Value
ISO		
As Welded	20 °C	60 J
As Welded	-60 °C	52 J

Typical Weld Metal Analysis %

C	Mn	Si	Ni	Cr	Mo	N	FN WRC-92
0.03	0.7	0.8	12.5	18.2	2.9	0.09	4

Deposition Data

Diameter	Current	Voltage	Efficiency (%)	Fusion time per electrode at 90% I max	Deposition Rate
2.5 x 300 mm	60-90 A	34 V	61 %	35 sec	1.6 kg/h
3.2 x 350 mm	80-130 A	36 V	58 %	50 sec	2.1 kg/h
4.0 x 450 mm	110-180 A	37 V	60 %	70 sec	2.9 kg/h
5.0 x 450 mm	170-240 A	42 V	61 %	82 sec	4.0 kg/h

OK 63.80



Acid rutile covered MMA-electrode for welding Nb -or Ti-stabilized stainless steels of the CrNiMo 18-12-3 type.

Specifications	
Classifications	EN ISO 3581-A : E 19 12 3 Nb R 3 2 SFA/AWS A5.4 : E318-17 Werkstoffnummer : 1.4576
Approvals	CE : EN 13479 UKCA : EN 13479 VdTUV : 00639

Approvals are based on factory location. Please contact ESAB for more information.

Welding Current	DC+, AC
Ferrite Content	FN 6-12
Alloy Type	Austenitic CrNi
Coating Type	Acid Rutile
Min AC OCV	50

Typical Tensile Properties			
Condition	Yield Strength	Tensile Strength	Elongation
ISO			
As Welded	507 MPa	614 MPa	38 %

Typical Charpy V-Notch Properties		
Condition	Testing Temperature	Impact Value
ISO		
As Welded	20 °C	55 J
As Welded	-60 °C	41 J

Typical Weld Metal Analysis %								
C	Mn	Si	Ni	Cr	Mo	N	Nb	FN WRC-92
0.02	0.6	0.8	11.5	18.2	2.9	0.08	0.31	7

Deposition Data						
Diameter	Current	Voltage	Efficiency (%)	Fusion time per electrode at 90% I max	Deposition Rate	
2.0 x 300 mm	45-65 A	29 V	56 %	29 sec	0.8 kg/h	
2.5 x 300 mm	60-90 A	30 V	56 %	35 sec	1.1 kg/h	
3.2 x 350 mm	80-120 A	32 V	61 %	54 sec	1.4 kg/h	
4.0 x 350 mm	120-170 A	33 V	61 %	55 sec	2.1 kg/h	

OK 63.85



Basic MMA-electrode for welding Nb-stabilized stainless steels of 18Cr 12Ni 3Mo-type.

Specifications

Classifications	EN ISO 3581-A : E 19 12 3 Nb B 42 SFA/AWS A5.4 : E318-15 Werkstoffnummer : 1.4576
Approvals	VdTÜV : 05662

Approvals are based on factory location. Please contact ESAB for more information.

Welding Current	DC+
Ferrite Content	FN 5-10
Alloy Type	Nb-stabilized austenitic CrNiMo-type
Coating Type	Lime Basic

Typical Tensile Properties

Condition	Yield Strength	Tensile Strength	Elongation
AWS			
As Welded	490 MPa	640 MPa	35 %

Typical Charpy V-Notch Properties

Condition	Testing Temperature	Impact Value
AWS		
As Welded	20 °C	65 J
As Welded	-120 °C	45 J

Typical Weld Metal Analysis %

C	Mn	Si	Ni	Cr	Mo	N	Nb	FN WRC-92
0.04	1.6	0.5	13.0	17.9	2.7	0.06	0.55	5

Deposition Data

Diameter	Current	Voltage	Efficiency (%)	Fusion time per electrode at 90% I max	Deposition Rate
2.5 x 300 mm	50-80 A	22 V	66 %	45 sec	1.0 kg/h
3.2 x 350 mm	65-120 A	23 V	64 %	58 sec	1.5 kg/h

OK 64.30



OK 64.30 is a low carbon rutile covered electrode for welding of 19Cr 13Ni 3-4Mo- type stainless steel. The higher molybdenum content provides a higher pitting corrosion resistance than E316L types.

Specifications	
Classifications	EN ISO 3581-A : E Z 19 13 4 N L R 3 2 SFA/AWS A5.4 : E317L-17 Werkstoffnummer : (1.4447)
Approvals	VdTÜV : 02311

Approvals are based on factory location. Please contact ESAB for more information.

Welding Current	DC+, AC
Ferrite Content	FN 5-10
Alloy Type	Austenitic CrNiMo
Coating Type	Acid Rutile
Min AC OCV	55

Typical Tensile Properties			
Condition	Yield Strength	Tensile Strength	Elongation
AWS			
As Welded	480 MPa	600 MPa	35 %
ISO			
As Welded	480 MPa	600 MPa	30 %

Typical Charpy V-Notch Properties		
Condition	Testing Temperature	Impact Value
ISO		
As Welded	20 °C	49 J
As Welded	-20 °C	46 J

Typical Weld Metal Analysis %							
C	Mn	Si	Ni	Cr	Mo	N	FN WRC-92
0.02	0.7	0.7	13.1	18.4	3.6	0.08	8

Deposition Data					
Diameter	Current	Voltage	Efficiency (%)	Fusion time per electrode at 90° I max	Deposition Rate
2.5 x 300 mm	50-80 A	29 V	56 %	52 sec	0.8 kg/h
3.2 x 350 mm	60-120 A	30 V	56 %	52 sec	1.4 kg/h
4.0 x 350 mm	80-170 A	32 V	56 %	58 sec	2.1 kg/h

OK 67.13



Austenitic stainless steel electrode for welding 25Cr20Ni steels. The weld metal does not contain any measurable ferrite and resists scaling up to 1100-1150 °C.

Specifications

Classifications	EN ISO 3581-A : E 25 20 R 1 2 SFA/AWS A5.4 : E310-16 Werkstoffnummer : 1.4842
Approvals	CE : EN 13479 UKCA : EN 13479

Approvals are based on factory location. Please contact ESAB for more information.

Welding Current	DC+, AC
Ferrite Content	FN 0
Alloy Type	Austenitic CrNi
Coating Type	Basic Rutile
Min AC OCV	65

Typical Tensile Properties

Condition	Yield Strength	Tensile Strength	Elongation
AWS			
As Welded	430 MPa	600 MPa	35 %

Typical Charpy V-Notch Properties

Condition	Testing Temperature	Impact Value
AWS		
As Welded	20 °C	90 J
ISO		
As Welded	20 °C	83 J

Typical Weld Metal Analysis %

C	Mn	Si	Ni	Cr
0.12	1.9	0.6	21.1	25.6

Deposition Data

Diameter	Current	Voltage	Efficiency (%)	Fusion time per electrode at 90% I max	Deposition Rate
2.5 x 300 mm	50-85 A	21 V	51 %	42 sec	0.8 kg/h
3.2 x 350 mm	65-120 A	24 V	51 %	58 sec	1.2 kg/h
4.0 x 350 mm	70-160 A	28 V	51 %	61 sec	1.7 kg/h

OK 67.15



Basic coated MMA-electrode for welding 25Cr 20Ni-steels. Also suitable for welding armour steels, austenitic manganese steels and for joining of dissimilar steels.

Specifications	
Classifications	EN ISO 3581-A : E 25 20 B 2 2 SFA/AWS A5.4 : E310-15 Werkstoffnummer : 1.4842
Approvals	CE : EN 13479 DB : 30.039.01 UKCA : EN 13479 VdTÜV : 01025

Approvals are based on factory location. Please contact ESAB for more information.

Welding Current	DC+
Ferrite Content	FN 0
Alloy Type	Austenitic CrNi
Coating Type	Lime Basic

Typical Tensile Properties			
Condition	Yield Strength	Tensile Strength	Elongation
ISO			
As Welded	410 MPa	590 MPa	35 %

Typical Charpy V-Notch Properties		
Condition	Testing Temperature	Impact Value
ISO		
As Welded	20 °C	100 J

Typical Weld Metal Analysis %				
C	Mn	Si	Ni	Cr
0.10	2.0	0.4	21.3	25.7

Deposition Data					
Diameter	Current	Voltage	Efficiency (%)	Fusion time per electrode at 90° I max	Deposition Rate
2.0 x 300 mm	45-55 A	24 V	62 %	36 sec	0.6 kg/h
2.5 x 300 mm	50-85 A	25 V	61 %	40 sec	0.9 kg/h
3.2 x 350 mm	60-115 A	25 V	59 %	60 sec	1.2 kg/h
4.0 x 350 mm	70-160 A	26 V	59 %	62 sec	1.8 kg/h
5.0 x 350 mm	130-200 A	26 V	60 %	65 sec	2.5 kg/h

OK 67.43



Austenitic stainless steel MMA-electrode giving a weld metal of the CrNiMn-type. The weld metal, which contains a small amount of uniformly distributed ferrite, is tough and has an excellent crack resistance. Suitable for joining 13%Mn-steels and such steels to other steels. Also suitable for welding of other steels with very poor weldability.

Specifications

Classifications	EN 14700 : E Fe10 EN ISO 3581-A : E 18 8 Mn R 1 2 SFA/AWS A5.4 : (E307-16) Werkstoffnummer : 1.4370
Approvals	CE : EN 13479 DB : 30.039.07 UKCA : EN 13479 VdTUV : 06797

Approvals are based on factory location. Please contact ESAB for more information.

Welding Current	AC, DC+
Ferrite Content	FN <5
Alloy Type	Austenitic, CrNiMn
Coating Type	Rutile Basic
Min AC OCV	65

Typical Tensile Properties

Condition	Yield Strength	Tensile Strength	Elongation
ISO			
As Welded	440 MPa	630 MPa	35 %

Typical Charpy V-Notch Properties

Condition	Testing Temperature	Impact Value
ISO		
As Welded	20 °C	80 J
As Welded	-60 °C	52 J

Typical Weld Metal Analysis %

C	Mn	Si	Ni	Cr	N	FN WRC-92
0.08	5.4	0.8	9.1	18.4	0.08	2

Deposition Data

Diameter	Current	Voltage	Efficiency (%)	Fusion time per electrode at 90% I max	Deposition Rate
2.5 x 300 mm	60-80 A	22 V	51 %	46 sec	0.8 kg/h
3.2 x 350 mm	90-115 A	23 V	54 %	54 sec	1.3 kg/h
4.0 x 350 mm	100-150 A	23 V	56 %	61 sec	1.7 kg/h
5.0 x 450 mm	130-210 A	24 V	60 %	86 sec	2.8 kg/h

OK 67.45



Austenitic stainless steel electrode giving a weld metal with less than 5 % ferrite. The tough weld metal has an excellent crack resistance, also when welding steels with very poor weldability. Suitable for joining 12 to 14 % manganese steel with itself or other steels. Also suitable for buffer layers before hard facing.

Specifications	
Classifications	EN ISO 3581-A : E 18 8 Mn B 2 2 SFA/AWS A5.4 : (E307-15)
Approvals	ABS : Stainless CE : EN 13479 UKCA : EN 13479 VdTUV : 01580

Approvals are based on factory location. Please contact ESAB for more information.

Welding Current	DC+
Ferrite Content	FN <5
Alloy Type	Stainless austenitic CrNiMn
Coating Type	Lime Basic

Typical Tensile Properties			
Condition	Yield Strength	Tensile Strength	Elongation
ISO			
As Welded	470 MPa	605 MPa	35 %

Typical Charpy V-Notch Properties		
Condition	Testing Temperature	Impact Value
ISO		
As Welded	20 °C	85 J
As Welded	-60 °C	50 J

Typical Weld Metal Analysis %						
C	Mn	Si	Ni	Cr	N	FN WRC-92
0.09	6.3	0.3	9.1	18.8	0.06	2

Deposition Data					
Diameter	Current	Voltage	Efficiency (%)	Fusion time per electrode at 90° I max	Deposition Rate
2.5 x 300 mm	50-80 A	23 V	58 %	50 sec	0.7 kg/h
3.2 x 350 mm	70-100 A	24 V	60 %	71 sec	1.1 kg/h
4.0 x 350 mm	80-140 A	24 V	60 %	73 sec	1.5 kg/h
5.0 x 350 mm	150-200 A	25 V	60 %	80 sec	2.2 kg/h

OK 67.50



OK 67.50 is an acid rutile coated type for welding of austenitic-ferritic stainless steels of CrNiMoN 22 5 3 - and CrNiN 23 4-types. The duplex all weld metal offers a high strength level combined with good ductility. The pitting corrosion resistance is good and the all weld metal is not sensitive for stress corrosion cracking.

Specifications	
Classifications	EN ISO 3581-A : E 22 9 3 N L R 3 2 SFA/AWS A5.4 : E2209-17 CSA W48 : E2209-17 Werkstoffnummer : 1.4462
Approvals	ABS : E2209-17 ABS : Stainless* BV : 2209 CE : EN 13479 CWB : E2209-17 DNV-GL : Duplex RINA : 2209 UKCA : EN 13479 VdTÜV : 04368

Approvals are based on factory location. Please contact ESAB for more information.

Welding Current	DC+, AC
Ferrite Content	FN 35-50
Alloy Type	Duplex CrNiMoN
Coating Type	Acid Rutile
Min AC OCV	60

Typical Tensile Properties			
Condition	Yield Strength	Tensile Strength	Elongation
ISO			
As Welded	691 MPa	857 MPa	25 %

Typical Charpy V-Notch Properties		
Condition	Testing Temperature	Impact Value
ISO		
As Welded	20 °C	50 J
As Welded	-30 °C	41 J

Typical Weld Metal Analysis %							
C	Mn	Si	Ni	Cr	Mo	N	FN WRC-92
0.03	0.8	0.8	8.8	23.2	3.2	0.16	42

Deposition Data					
Diameter	Current	Voltage	Efficiency (%)	Fusion time per electrode at 90% I max	Deposition Rate
2.0 x 300 mm	30-65 A	29 V	55 %	33 sec	0.7 kg/h
2.5 x 300 mm	50-90 A	27 V	58 %	38 sec	1.0 kg/h
3.2 x 350 mm	80-120 A	28 V	58 %	55 sec	1.4 kg/h
4.0 x 350 mm	90-160 A	29 V	58 %	59 sec	1.9 kg/h
5.0 x 350 mm	150-220 A	30 V	58 %	64 sec	2.8 kg/h

OK 67.55



Basic coated electrode especially designed for welding duplex stainless steels i.e. UNS S31803. Suitable for applications where the requirements on the mechanical properties are high.

Specifications	
Classifications	EN ISO 3581-A : E 22 9 3 N L B 2 2 SFA/AWS A5.4 : E2209-15 Werkstoffnummer : 1.4462
Approvals	DNV-GL : Duplex VdTÜV : 06774

Approvals are based on factory location. Please contact ESAB for more information.

Welding Current	DC+
Ferrite Content	FN 35-50
Alloy Type	Austenitic CrNiMo
Coating Type	Basic

Typical Tensile Properties			
Condition	Yield Strength	Tensile Strength	Elongation
ISO			
As Welded	650 MPa	800 MPa	28 %

Typical Charpy V-Notch Properties		
Condition	Testing Temperature	Impact Value
ISO		
As Welded	20 °C	100 J
As Welded	-20 °C	85 J
As Welded	-40 °C	75 J
As Welded	-60 °C	65 J

Typical Weld Metal Analysis %							
C	Mn	Si	Ni	Cr	Mo	N	FN WRC-92
0.04	1.0	0.7	9.1	23.2	3.2	0.15	41

Deposition Data					
Diameter	Current	Voltage	Efficiency (%)	Fusion time per electrode at 90% I max	Deposition Rate
2.5 x 300 mm	50-80 A	23 V	59 %	49 sec	0.8 kg/h
3.2 x 350 mm	65-115 A	24 V	59 %	61 sec	1.2 kg/h
4.0 x 350 mm	80-140 A	24 V	60 %	74 sec	1.5 kg/h

OK 67.60



Acid-rutile coated MMA-electrode giving an overalllyed weld metal. Suitable for welding stainless steel to mild and low alloyed steels. Also suitable for welding of transition layers when surfacing mild steel with stainless steel weld metal.

Specifications	
Classifications	EN ISO 3581-A : E 23 12 L R 3 2 SFA/AWS A5.4 : E309L-17 CSA W48 : E309L-17 Werkstoffnummer : 1.4332
Approvals	CE : EN 13479 CWB : E309L-17 DNV-GL : VL 309 UKCA : EN 13479 VdTUV : 00898

Approvals are based on factory location. Please contact ESAB for more information.

Welding Current	DC+, AC
Ferrite Content	FN 10-22
Alloy Type	Austenitic CrNi
Coating Type	Acid Rutile
Min AC OCV	55

Typical Tensile Properties			
Condition	Yield Strength	Tensile Strength	Elongation
ISO			
As Welded	470 MPa	580 MPa	32 %

Typical Charpy V-Notch Properties		
Condition	Testing Temperature	Impact Value
ISO		
As Welded	20 °C	50 J
As Welded	-10 °C	40 J

Typical Weld Metal Analysis %						
C	Mn	Si	Ni	Cr	N	FN WRC-92
0.03	0.9	0.8	12.4	23.7	0.09	15

Deposition Data					
Diameter	Current	Voltage	Efficiency (%)	Fusion time per electrode at 90% I max	Deposition Rate
2.0 x 300 mm	45-65 A	27 V	60 %	38 sec	0.7 kg/h
2.5 x 300 mm	45-90 A	28 V	60 %	38 sec	1.1 kg/h
3.2 x 350 mm	65-120 A	29 V	60 %	51 sec	1.6 kg/h
4.0 x 350 mm	85-180 A	31 V	60 %	51 sec	2.5 kg/h
5.0 x 350 mm	110-250 A	32 V	60 %	58 sec	3.3 kg/h

OK 67.70



Acid rutile MMA-electrode giving an over alloyed weld metal. Suitable for welding acid resistant stainless steels to mild and low alloyed steels. Also suitable for welding buffer layers when surfacing mild steel with acid resistant stainless steel weld metal.

Specifications	
Classifications	EN ISO 3581-A : E 23 12 2 L R 3 2 SFA/AWS A5.4 : E309LMo-17 CSA W48 : E309LMo-17 Werkstoffnummer : 1.4459
Approvals	ABS : SS to C- & CMn steels BV : 309Mo CE : EN 13479 CWB : E309LMo-17 DB : 30.039.05 DNV-GL : VL 309 Mo LR : SS/CMn RINA : 309MO UKCA : EN 13479 VdTUV : 02424

Approvals are based on factory location. Please contact ESAB for more information.

Welding Current	DC+, AC
Ferrite Content	FN 12-22
Alloy Type	Austenitic CrNi
Coating Type	Acid Rutile
Min AC OCV	55

Typical Tensile Properties			
Condition	Yield Strength	Tensile Strength	Elongation
ISO			
As Welded	510 MPa	610 MPa	32 %

Typical Charpy V-Notch Properties		
Condition	Testing Temperature	Impact Value
ISO		
As Welded	20 °C	50 J
As Welded	-20 °C	35 J

Typical Weld Metal Analysis %							
C	Mn	Si	Ni	Cr	Mo	N	FN WRC-92
0.02	0.6	0.8	13.4	22.5	2.8	0.09	18

Deposition Data					
Diameter	Current	Voltage	Efficiency (%)	Fusion time per electrode at 90% I max	Deposition Rate
2.0 x 300 mm	40-60 A	26 V	58 %	48 sec	0.6 kg/h
2.5 x 300 mm	50-90 A	29 V	57 %	45 sec	0.9 kg/h
3.2 x 350 mm	60-120 A	27 V	59 %	61 sec	1.4 kg/h
4.0 x 350 mm	85-180 A	31 V	61 %	56 sec	2.0 kg/h

OK 67.70

Deposition Data

Diameter	Current	Voltage	Efficiency (%)	Fusion time per electrode at 90% I max	Deposition Rate
5.0 x 350 mm	110-250 A	30 V	59 %	64 sec	2.7 kg/h

OK 67.75



Basic coated stainless steel electrode for welding steels of the type 24Cr13Ni, welding transition layers when surfacing mild steel with stainless, joining dissimilar steels and welding root runs in the stainless side of clad steels.

Specifications	
Classifications	EN ISO 3581-A : E 23 12 L B 4 2 SFA/AWS A5.4 : E309L-15 Werkstoffnummer : 1.4332
Approvals	ABS : Stainless CE : EN 13479 DNV-GL : VL 309 LR : SS/CMn UKCA : EN 13479 VdTUV : 00633

Approvals are based on factory location. Please contact ESAB for more information.

Welding Current	DC+
Ferrite Content	FN 8-15
Alloy Type	Austenitic CrNi
Coating Type	Basic

Typical Tensile Properties			
Condition	Yield Strength	Tensile Strength	Elongation
AWS			
As Welded	470 MPa	600 MPa	35 %

Typical Charpy V-Notch Properties		
Condition	Testing Temperature	Impact Value
AWS		
As Welded	20 °C	75 J
As Welded	-50 °C	64 J
As Welded	-80 °C	55 J

Typical Weld Metal Analysis %						
C	Mn	Si	Ni	Cr	N	FN WRC-92
0.04	2.0	0.3	12.9	23.5	0.06	11

Deposition Data					
Diameter	Current	Voltage	Efficiency (%)	Fusion time per electrode at 90% I max	Deposition Rate
2.5 x 300 mm	50-80 A	22 V	73 %	42 sec	1.1 kg/h
3.2 x 350 mm	80-120 A	24 V	73 %	60 sec	1.5 kg/h
4.0 x 350 mm	80-150 A	26 V	73 %	62 sec	2.3 kg/h

OK 68.15



Stainless steel MMA electrode, giving a weld metal of the 13% Cr type. Intended for welding steels of similar composition when Cr/Ni alloyed austenitic stainless steel electrodes cannot be used, e.g. when the construction will be exposed to aggressive sulphuric gases.

Specifications

Classifications	EN 14700 : E Fe7 EN ISO 3581-A : E 13 B 4 2 SFA/AWS A5.4 : E410-15 Werkstoffnummer : 1.4009
------------------------	--

Welding Current	DC+
Alloy Type	13% Cr
Coating Type	Lime Basic

Typical Tensile Properties

Condition	Yield Strength	Tensile Strength	Elongation
AWS			
Stress Relieved 1 hour(s) 750 °C	370 MPa	520 MPa	25 %

Typical Charpy V-Notch Properties

Condition	Testing Temperature	Impact Value
AWS		
Stress Relieved 6 hour(s) 750 °C	20 °C	55 J
Stress Relieved 6 hour(s) 750 °C	0 °C	35 J
Stress Relieved 6 hour(s) 750 °C	-20 °C	20 J

Typical Weld Metal Analysis %

C	Mn	Si	Ni	Cr
0.04	0.3	0.4	0.1	12.9

Deposition Data

Diameter	Current	Voltage	Efficiency (%)	Fusion time per electrode at 90° I max	Deposition Rate
2.5 x 350 mm	65-115 A	25 V	62 %	48 sec	1.0 kg/h
3.2 x 450 mm	90-160 A	25 V	63 %	71 sec	1.5 kg/h
4.0 x 450 mm	120-220 A	30 V	57 %	73 sec	2.0 kg/h

OK 68.17



A rutile-basic electrode for welding martensitic 13Cr4Ni-Mo type steels.

Specifications

Classifications	EN 14700 : E Fe7 EN ISO 3581-A : E 13 4 R 3 2 SFA/AWS A5.4 : E410NiMo-16 Werkstoffnummer : 1.4351
------------------------	--

Welding Current	DC+, AC
Diffusible Hydrogen	<8,0 ml/100g
Alloy Type	Martensitic 13Cr4Ni-Mo type
Coating Type	Rutile Basic
Min AC OCV	55

Typical Tensile Properties

Condition	Yield Strength	Tensile Strength	Elongation
ISO			
Stress relieved+ 8 hour(s) 600 °C	650 MPa	870 MPa	17 %

Typical Charpy V-Notch Properties

Condition	Testing Temperature	Impact Value
ISO		
Stress relieved+ 8 hour(s) 600 °C	20 °C	45 J
Stress relieved+ 8 hour(s) 600 °C	-10 °C	45 J
Stress relieved+ 8 hour(s) 600 °C	-40 °C	40 J

Typical Weld Metal Analysis %

C	Mn	Si	Ni	Cr	Mo
0.02	0.6	0.4	4.6	12.0	0.6

Deposition Data

Diameter	Current	Voltage	Efficiency (%)	Fusion time per electrode at 90% I max	Deposition Rate
2.5 x 350 mm	55-100 A	21 V	62 %	61 sec	0.8 kg/h
3.2 x 350 mm	65-135 A	21 V	59 %	66 sec	1.2 kg/h
4.0 x 450 mm	90-190 A	24 V	59 %	92 sec	1.7 kg/h

OK 68.25



Basic coated electrode for welding corrosion resistant martensitic and martensitic-ferritic rolled, forged and cast steels, for example castings of 13Cr4NiMo-type.

Specifications

Classifications	EN 14700 : E Fe7 EN ISO 3581-A : E 13 4 B 4 2 SFA/AWS A5.4 : E410NiMo-15 Werkstoffnummer : 1.4351
------------------------	--

Welding Current	DC+
Diffusible Hydrogen	<5.0 ml/100g
Alloy Type	Martensitic-ferritic
Coating Type	Basic

Typical Tensile Properties

Condition	Yield Strength	Tensile Strength	Elongation
ISO			
PWHT 8 hour(s) 600 °C	680 MPa	900 MPa	17 %

Typical Charpy V-Notch Properties

Condition	Testing Temperature	Impact Value
ISO		
PWHT 8 hour(s) 600 °C	20 °C	65 J
PWHT 8 hour(s) 600 °C	0 °C	60 J
PWHT 8 hour(s) 600 °C	-20 °C	55 J

Typical Weld Metal Analysis %

C	Mn	Si	Ni	Cr	Mo
0.04	0.6	0.4	4.5	12.2	0.6

Deposition Data

Diameter	Current	Voltage	Efficiency (%)	Fusion time per electrode at 90% I max	Deposition Rate
3.2 x 450 mm	90-150 A	28 V	64 %	63 sec	1.6 kg/h
4.0 x 450 mm	110-190 A	28 V	66 %	73 sec	2.2 kg/h
5.0 x 450 mm	140-250 A	27 V	67 %	86 sec	3.1 kg/h

OK 68.53



Stainless MMA electrode for welding austenitic-ferritic stainless steels of the so called Superduplex types i.e. steel grade SAF 2507 and Zeron 100.

Specifications	
Classifications	EN ISO 3581-A : E 25 9 4 N L R 32 SFA/AWS A5.4 : E2594-16 Werkstoffnummer : (1.4410)
Approvals	CE : EN 13479 DNV-GL : Duplex UKCA : EN 13479 VdTÜV : 07377

Approvals are based on factory location. Please contact ESAB for more information.

Welding Current	DC+, AC
Ferrite Content	FN 35-50
Alloy Type	Austenitic-ferritic CrNiMo
Coating Type	Basic Rutile
Min AC OCV	60

Typical Tensile Properties			
Condition	Yield Strength	Tensile Strength	Elongation
ISO			
As Welded	700 MPa	850 MPa	30 %

Typical Charpy V-Notch Properties		
Condition	Testing Temperature	Impact Value
ISO		
As Welded	20 °C	50 J
As Welded	-40 °C	40 J

Typical Weld Metal Analysis %						
C	Si	Ni	Cr	Mo	N	FN WRC-92
0.03	0.6	10.3	25.2	4	0.25	39

Deposition Data					
Diameter	Current	Voltage	Efficiency (%)	Fusion time per electrode at 90° I max	Deposition Rate
2.5 x 300 mm	55-85 A	22 V	60 %	43 sec	0.9 kg/h
3.2 x 350 mm	70-110 A	22 V	60 %	62 sec	1.2 kg/h
4.0 x 350 mm	80-150 A	23 V	60 %	67 sec	1.7 kg/h

OK 68.55



Stainless MMA electrode for welding austenitic-ferritic stainless steels of the so called "Superduplex-type", e.g. SAF 2507 and Zeron 100.

Specifications

Classifications	EN ISO 3581-A : E 25 9 4 N L B 4 2 SFA/AWS A5.4 : E2594-15 Werkstoffnummer : (1.4410)
Approvals	DNV-GL : Duplex

Approvals are based on factory location. Please contact ESAB for more information.

Welding Current	DC+
Ferrite Content	FN 35-50
Alloy Type	Austenitic CrNiMo
Coating Type	Basic

Typical Tensile Properties

Condition	Yield Strength	Tensile Strength	Elongation
ISO			
As Welded	700 MPa	900 MPa	28 %

Typical Charpy V-Notch Properties

Condition	Testing Temperature	Impact Value
ISO		
As Welded	20 °C	90 J
As Welded	-20 °C	70 J
As Welded	-40 °C	55 J
As Welded	-60 °C	45 J

Typical Weld Metal Analysis %

C	Mn	Si	Ni	Cr	Mo	N	FN WRC-92
0.03	0.9	0.6	10.4	25.2	4.3	0.23	45

Deposition Data

Diameter	Current	Voltage	Efficiency (%)	Fusion time per electrode at 90% I max	Deposition Rate
2.5 x 300 mm	50-80 A	23 V	62 %	48 sec	0.8 kg/h
3.2 x 350 mm	60-100 A	23 V	63 %	68 sec	1.1 kg/h
4.0 x 350 mm	100-140 A	23 V	62 %	70 sec	1.6 kg/h

OK 68.81



High alloy stainless electrode of unusual versatility, giving a ferritic-austenitic duplex weld metal with an approximate ferrite content of FN 40. The weld metal is resistant to stress corrosion attack and highly insensitive to dilution by melted parent metal. Applications: joining of HWT steels, dissimilar steels, surfacing rails, rolls, alforjng dies, hot work tools, dies for plastics etc. Good scaling resistance up to 1150 °C.

Specifications	
Classifications	EN 14700 : E Fe11 EN ISO 3581-A : E 29 9 R 3 2 SFA/AWS A5.4 : E312-17 Werkstoffnummer : 1.4337
Approvals	CE : EN 13479 UKCA : EN 13479

Approvals are based on factory location. Please contact ESAB for more information.

Welding Current	DC+, AC
Ferrite Content	FN 30 - 50
Alloy Type	Stainless duplex
Coating Type	Acid Rutile
Min AC OCV	60

Typical Tensile Properties			
Condition	Yield Strength	Tensile Strength	Elongation
AWS			
As Welded	610 MPa	790 MPa	25 %

Typical Charpy V-Notch Properties		
Condition	Testing Temperature	Impact Value
AWS		
As Welded	20 °C	30 J

Typical Weld Metal Analysis %							
C	Mn	Si	Ni	Cr	Mo	N	FN WRC-92
0.13	0.9	0.7	10.2	28.9	0.04	0.09	40

Deposition Data					
Diameter	Current	Voltage	Efficiency (%)	Fusion time per electrode at 90% I max	Deposition Rate
2.0 x 300 mm	40-60 A	22 V	64 %	41 sec	0.7 kg/h
2.5 x 300 mm	50-85 A	24 V	64 %	48 sec	0.9 kg/h
3.2 x 350 mm	60-125 A	25 V	62 %	65 sec	1.3 kg/h
4.0 x 350 mm	80-175 A	26 V	62 %	66 sec	2.0 kg/h
5.0 x 350 mm	150-240 A	28 V	65 %	68 sec	3.2 kg/h

OK 68.82



High alloy stainless electrode of unusual versatility, giving a ferritic-austenitic duplex weld metal with an approximate ferrite content of FN 40. The weld metal is resistant to stress corrosion attack and highly insensitive to dilution by melted parent metal. Applications: joining of HWT steels, dissimilar steels, welding steels of poor weldability eg spring steels, surfacing rails, rolls forging die hot work tools, die for plastics, etc. Good scaling resistance up to 1150 °C.

Specifications

Classifications	EN 14700 : E Fe11 EN ISO 3581-A : E 29 9 R 1 2 SFA/AWS A5.4 : (E312-17) Werkstoffnummer : 1.4337
Approvals	CE : EN 13479 UKCA : EN 13479

Approvals are based on factory location. Please contact ESAB for more information.

Welding Current	DC+, AC
Ferrite Content	FN 30 - 50
Alloy Type	Stainless duplex
Coating Type	Acid Rutile
Min AC OCV	55

Typical Tensile Properties

Condition	Yield Strength	Tensile Strength	Elongation
AWS			
As Welded	500 MPa	750 MPa	25 %

Typical Charpy V-Notch Properties

Condition	Testing Temperature	Impact Value
AWS		
As Welded	20 °C	40 J

Typical Weld Metal Analysis %

C	Mn	Si	Ni	Cr	Mo	N	FN WRC-92
0.13	0.6	1.1	9.9	29.1	0.2	0.10	40

Deposition Data

Diameter	Current	Voltage	Efficiency (%)	Fusion time per electrode at 90% I max	Deposition Rate
2.0 x 300 mm	40-60 A	26 V	54 %	33 sec	0.7 kg/h
2.5 x 300 mm	50-85 A	25 V	52 %	45 sec	1.0 kg/h
3.2 x 350 mm	55-120 A	26 V	52 %	57 sec	1.3 kg/h
4.0 x 350 mm	75-170 A	30 V	55 %	60 sec	2.0 kg/h

OK 69.25



Basic coated stainless electrode for welding corrosion resistant, non-magnetic and cryogenic stainless steels. The electrode is giving a fully austenitic Cr-Ni-Mo weld metal with increased Mn- and N-content.

Specifications	
Classifications	EN ISO 3581-A : E 20 16 3 Mn N L B 4 2 SFA/AWS A5.4 : E316LMn-15 Werkstoffnummer : 1.4455

Welding Current	DC+
Ferrite Content	FN <0.5
Alloy Type	CrNiMo
Coating Type	Basic

Typical Tensile Properties			
Condition	Yield Strength	Tensile Strength	Elongation
ISO			
As Welded	450 MPa	650 MPa	35 %

Typical Charpy V-Notch Properties		
Condition	Testing Temperature	Impact Value
ISO		
As Welded	20 °C	90 J
As Welded	-196 °C	50 J

Typical Weld Metal Analysis %							
C	Mn	Si	Ni	Cr	Mo	N	FN WRC-92
0.04	6.5	0.5	16.0	19.0	3.0	0.15	0

Deposition Data						
Diameter	Current	Voltage	Efficiency (%)	Fusion time per electrode at 90% I max	Deposition Rate	
3.2 x 350 mm	70-100 A	24 V	62 %	72 sec	1.2 kg/h	
4.0 x 350 mm	100-140 A	25 V	64 %	74 sec	1.8 kg/h	

OK 69.33



Stainless steel electrode giving a fully austenitic weld metal highly resistant to sulphuric acid. The resistance to intergranular and pitting corrosion is good.

Specifications

Classifications	EN ISO 3581-A : E 20 25 5 Cu N L R 3 2 SFA/AWS A5.4 : E385-16 Werkstoffnummer : 1.4519
Approvals	CE : EN 13479 UKCA : EN 13479 VdTUV : 02723

Approvals are based on factory location. Please contact ESAB for more information.

Welding Current	AC, DC+
Ferrite Content	FN 0
Alloy Type	Austenitic CrNi
Coating Type	Basic Rutile
Min AC OCV	65

Typical Tensile Properties

Condition	Yield Strength	Tensile Strength	Elongation
ISO			
As Welded	410 MPa	590 MPa	35 %

Typical Charpy V-Notch Properties

Condition	Testing Temperature	Impact Value
ISO		
As Welded	20 °C	80 J
As Welded	-140 °C	70 J

Typical Weld Metal Analysis %

C	Mn	Si	Ni	Cr	Mo	Cu	N	FN WRC-92
0.03	1.0	0.5	25.5	20.5	4.8	1.70	0.10	0

Deposition Data

Diameter	Current	Voltage	Efficiency (%)	Fusion time per electrode at 90% I max	Deposition Rate
2.5 x 300 mm	60-85 A	24 V	60 %	44 sec	0.9 kg/h
3.2 x 350 mm	85-130 A	27 V	58 %	60 sec	1.5 kg/h
4.0 x 350 mm	95-180 A	29 V	51 %	64 sec	1.9 kg/h

OK 310Mo-L



Basic electrode for joining and cladding of steel containing 25% Cr 22% Ni 2% Mo N type. The weld metal has an excellent resistance to very aggressive corrosive media, such as in urea plants. The fully austenitic weld metal is insensitive to hot cracking. OK 310Mo-L is approved for construction and repair of urea plants using the stamicarbon process. The electrode is regularly used for routine repair works on AISI 316L in urea plants to gain superior resistance to corrosive attack.

Specifications	
Classifications	EN ISO 3581-A : E 25 22 2 N L R 1 2 SFA/AWS A5.4 : (E310Mo-16)
Approvals	Snamprogetti : Ureaplants Stamicarbon : Ureaplants

Approvals are based on factory location. Please contact ESAB for more information.

Welding Current	DC+
Ferrite Content	FN 0
Alloy Type	25Cr 22Ni 2Mo N
Coating Type	Rutile Basic

Typical Tensile Properties			
Condition	Yield Strength	Tensile Strength	Elongation
ISO			
As Welded	442 MPa	623 MPa	34 %

Typical Charpy V-Notch Properties		
Condition	Testing Temperature	Impact Value
ISO		
As Welded	20 °C	54 J

Typical Weld Metal Analysis %							
C	Mn	Si	Ni	Cr	Mo	N	FN WRC-92
0.038	4.4	0.4	21.7	24.2	2.4	0.14	0

Deposition Data						
Diameter	Current	Voltage	Efficiency (%)	Fusion time per electrode at 90° I max	Deposition Rate	
2.5 x 300 mm	55-70 A	24 V	72 %	52 sec	0.9 kg/h	
3.2 x 350 mm	70-100 A	24 V	56 %	62 sec	1.1 kg/h	
4.0 x 350 mm	100-140 A	25 V	55 %	62 sec	1.7 kg/h	

Exaton 22.9.3.LB



Exaton 22.9.3.LB is a chromium-nickel-molybdenum-nitrogen covered electrode with basic coating for welding of 22-23%Cr duplex (austenitic-ferritic) stainless steels (e.g. SAF 2205). The basic type of electrode combines good welding properties in all positions and high impact strength at low temperatures. The weld metal is characterized by high strength and very good pitting corrosion resistance as well as very good resistance to stress corrosion cracking in chloride containing media. Exaton 22.9.3.LB is used for welding of duplex and lean duplex stainless steels in service temperatures up to 280°C (536°F). It is also used in applications where good impact toughness properties is required below -40°C. Typical base materials to be welded are ISO: 1.4462, 1.4362, 1.4162, 1.4662, 1.4660 and 1.4417.

Specifications	
Classifications	EN ISO 3581-A : E 22 9 3 N L B SFA/AWS A5.4 : E2209-15 Werkstoffnummer : 1.4462
Approvals	BV : E2209-15 CE : EN13479 DNV : Duplex UKCA : EN13479

Approvals are based on factory location. Please contact ESAB for more information.

Welding Current	DC+
Ferrite Content	FN 35-50
Alloy Type	Duplex CrNiMoN
Coating Type	Basic

Typical Tensile Properties			
Condition	Yield Strength	Tensile Strength	Elongation
ISO			
As Welded	670 MPa	840 MPa	27 %

Typical Charpy V-Notch Properties		
Condition	Testing Temperature	Impact Value
ISO		
As Welded	20 °C	110 J
As Welded	-46 °C	80 J
As Welded	-60 °C	67 J

Typical Weld Metal Analysis %									
C	Mn	Si	S	P	Ni	Cr	Mo	Cu	N
<=0.04	1	0.6	<=0.025	<=0.03	9	23	3.2	0.1	0.18

Typical Weld Metal Analysis %	
PRE	FN WRC-92
>=35	44

Deposition Data					
Diameter	Current	Voltage	Efficiency (%)	Fusion time per electrode at 90° I max	Deposition Rate
2.5 x 300 mm	55-80 A	24 V	56 %	49 sec	0.7 kg/h
3.2 x 350 mm	70-115 A	24 V	60 %	61 sec	1.2 kg/h
4.0 x 350 mm	90-175 A	25 V	57 %	62 sec	1.6 kg/h

Exaton 22.9.3.LR



Exaton 22.9.3.LR is a chromium-nickel-molybdenum-nitrogen covered electrode with rutile coating for welding of 22-23%Cr duplex (ferritic-austenitic) stainless steels (e.g. SAF 2205). The ferrite content in the all weld metal is approximately 40 FN according to WRC-92. The electrode provides excellent arc stability, low spatter, self peeling slag and smooth weld bead finishing. The all weld metal is characterized by high strength and very good resistance against pitting corrosion (in chloride containing media) as well as stress corrosion cracking. Exaton 22.9.3.LR is used for welding of duplex and lean duplex stainless steels in service temperatures up to 280°C (536°F). Typical base materials welded include ISO: 1.4462, 1.4362, 1.4162, 1.4662, 1.4460 and 1.4417.

Specifications	
Classifications	EN ISO 3581-A : E 22 9 3 N L R SFA/AWS A5.4 : E2209-17 Werkstoffnummer : 1.4462
Approvals	CE : EN 13479 CWB : E2209-17 UKCA : EN 13479 VdTÜV : 19476

Approvals are based on factory location. Please contact ESAB for more information.

Welding Current	DC+, AC
Ferrite Content	FN 30-60
Alloy Type	Duplex CrNiMoN
Coating Type	Acid Rutile
Min AC OCV	60

Typical Tensile Properties			
Condition	Yield Strength	Tensile Strength	Elongation
ISO			
As Welded	690 MPa	850 MPa	25 %

Typical Charpy V-Notch Properties		
Condition	Testing Temperature	Impact Value
ISO		
As Welded	20 °C	60 J
As Welded	-40 °C	40 J

Typical Weld Metal Analysis %									
C	Mn	Si	S	P	Ni	Cr	Mo	Cu	N
<=0.03	0.7	0.8	<=0.025	<=0.03	9	23	3	0.1	0.18

Typical Weld Metal Analysis %	
PRE	FN WRC-92
=>35.0	37

Deposition Data					
Diameter	Current	Voltage	Efficiency (%)	Fusion time per electrode at 90° I max	Deposition Rate
2.5 x 300 mm	50-100 A	29 V	54 %	34 sec	1.1 kg/h
3.2 x 350 mm	70-130 A	28 V	59 %	50 sec	1.5 kg/h
4.0 x 350 mm	75-185 A	29 V	58 %	53 sec	2.1 kg/h

Exaton 22.12.HTR



Exaton 22.12.HTR is a covered electrode with rutile-acid coating. It gives a chromium-nickel weld metal that is scaling resistant in air up to 1150°C (2102°F). Spray transfer gives a bead with a finely rippled surface. There is little spatter and very good slag removal. Exaton 22.12.HTR is intended primarily for welding the high temperature steels Alleima 253MA (1) and Avesta 253MA, UNS S30815. It is also suitable for welding other high temperature steels, such as AISI 309 and EN 1.4828. The core wire used contains Ce. (1): 253MA is a trademark owned by Outokumpu Stainless.

Specifications

Classifications	EN ISO 3581-A : E Z 23 10 N R 12
Approvals	CE : EN 13479 UKCA : EN 13479

Approvals are based on factory location. Please contact ESAB for more information.

Welding Current	AC, DC+
Ferrite Content	FN 4- 10
Alloy Type	CrNi stainless
Coating Type	Rutile
Min AC OCV	65

Typical Tensile Properties

Condition	Yield Strength	Tensile Strength	Elongation
ISO			
As Welded	540 MPa	720 MPa	35 %

Typical Charpy V-Notch Properties

Condition	Testing Temperature	Impact Value
ISO		
As Welded	20 °C	55 J

Typical Weld Metal Analysis %

C	Mn	Si	S	P	Ni	Cr	Mo	Cu	N
0.06	6	1.5	0.007	0.021	10.5	23	0.14	0.08	0.16

Typical Weld Metal Analysis %

FN WRC-92	PREN
6	25

Deposition Data

Diameter	Current	Voltage	Efficiency (%)	Fusion time per electrode at 90° I max	Deposition Rate
2.5 x 300 mm	50-90 A	26 V	55 %	44 sec	0.8 kg/h
3.2 x 350 mm	70-110 A	25 V	55 %	66 sec	1.0 kg/h
4.0 x 350 mm	85-150 A	26 V	56 %	77 sec	1.3 kg/h

Exaton 25.10.4.LB



Exaton 25.10.4.LB is a high alloyed chromium-nickel-molybdenum-nitrogen covered electrode with basic coating for welding of 25%Cr- and superduplex stainless steels (e.g. SAF 2507 and Zeron 100). The basic type of electrode combines good welding properties in all positions with high impact strength at low temperatures. The weld metal is characterized by high strength and very good corrosion resistance. Exaton 25.10.4.LB is used for welding of super duplex stainless steels in service temperatures up to 280°C (536°F), where good impact strength at temperatures down to -50°C is required. Common steel types include: ISO 1.4410, 1.4501 and 1.4507; UNS: S32750, S32760, S31260 and S32550. It can also be used as overmatching consumable for 21-23%Cr duplex stainless steels. The weld metals produced are not completely porosity free, but they fulfill the welding requirements described in ASME IX, Article 1 Welding Requirements- QW 191.1.

Specifications	
Classifications	EN ISO 3581-A : E 25 9 4 N L B SFA/AWS A5.4 : E2594-15 Werkstoffnummer : (1.4410)
Approvals	CE : EN 13479 UKCA : EN 13479

Approvals are based on factory location. Please contact ESAB for more information.

Welding Current	DC+
Ferrite Content	FN 35-55
Alloy Type	Austenitic-Ferritic CrNiMo
Coating Type	Basic

Typical Tensile Properties			
Condition	Yield Strength	Tensile Strength	Elongation
ISO			
As Welded	750 MPa	915 MPa	26 %

Typical Charpy V-Notch Properties		
Condition	Testing Temperature	Impact Value
ISO		
As Welded	20 °C	85 J
As Welded	-50 °C	45 J

Typical Weld Metal Analysis %									
C	Mn	Si	S	P	Ni	Cr	Mo	Cu	N
0.03	0.8	0.6	<=0.025	<=0.03	10	25	4	0.07	0.25

Typical Weld Metal Analysis %	
PRE	FN WRC-92
>=42	40

Deposition Data					
Diameter	Current	Voltage	Efficiency (%)	Fusion time per electrode at 90% I max	Deposition Rate
2.5 x 300 mm	50-80 A	22 V	62 %	50.2 sec	0.72 kg/h
3.2 x 350 mm	70-100 A	23 V	65 %	58.67 sec	1.2 kg/h
4.0 x 350 mm	100-150 A	-	73 %	-	2.0 kg/h

Exaton 25.10.4.LR



Exaton 25.10.4.LR is a covered electrode with rutile-basic coating used for welding of super-duplex (austenitic-ferritic) stainless steels of UNS S32750 and S32760 type (e.g. SAF 2507 and Zeron 100). The weld metal has excellent resistance against stress corrosion cracking, general- and pitting corrosion. It has also high resistance to erosion corrosion and corrosion fatigue. Spray transfer gives a bead with a finely rippled surface. There is little spatter and very good slag removal. The electrode has excellent arc stability and fast burn off rate with minimal stub loss. Typical applications include welding of austenitic-ferritic stainless steels such as SAF 2507, UNS S32750 (wrought) and UNS J93404 (cast) and other super-duplex steels, 25% chromium duplex stainless steels with PRE values between 37 and 40, dissimilar joints between duplex and carbon and low-alloy steels, SAF 2205 and corresponding duplex steels where the highest corrosion resistance is required.

Specifications	
Classifications	EN ISO 3581-A : E 25 9 4 N L R SFA/AWS A5.4 : E2594-16 Werkstoffnummer : (1.4410)
Approvals	CE : EN 13479 UKCA : EN 13479 VdTÜV : 07378

Approvals are based on factory location. Please contact ESAB for more information.

Welding Current	DC+, AC
Ferrite Content	FN 35-65
Alloy Type	Austenitic-Ferritic CrNiMo
Coating Type	Rutile Basic
Min AC OCV	60

Typical Tensile Properties			
Condition	Yield Strength	Tensile Strength	Elongation
ISO			
As Welded	730 MPa	900 MPa	25 %

Typical Charpy V-Notch Properties		
Condition	Testing Temperature	Impact Value
ISO		
As Welded	20 °C	70 J
As Welded	-40 °C	45 J

Typical Weld Metal Analysis %									
C	Mn	Si	S	P	Ni	Cr	Mo	Cu	N
0.03	1	0.5	<=0.025	<=0.03	9.5	25	4	0.09	0.25

Typical Weld Metal Analysis %	
FN WRC-92	PREN
45	>=42

Deposition Data					
Diameter	Current	Voltage	Efficiency (%)	Fusion time per electrode at 90% I max	Deposition Rate
2.5 x 300 mm	55-85 A	22 V	65 %	41 sec	0.9 kg/h
3.2 x 350 mm	70-110 A	22 V	63 %	67 sec	1.1 kg/h
4.0 x 350 mm	110-150 A	22 V	65 %	71 sec	1.4 kg/h

Exaton 25.22.2.LMnB



Exaton 25.22.2.LMnB is a chromium-nickel-molybdenum covered electrode with basic coating for welding of austenitic stainless steels for example, Sandvik 2RE69 and Sandvik 3R60 U.G used in the production of ammonium carbamate, nitric acid and inorganic acids. It is also used for surfacing on low alloyed steels. The electrode combines good welding properties such as arc stability, low spatter and self peeling slag with very low impurity levels. The fully austenitic weld metal (maximum 0.6% ferrite) is very resistant to hot cracking. Exaton 25.22.2.LMn is used for welding of Sandvik 2RE69 and Sandvik 3R60 U.G. urea grade materials. But it can also be used for the following types: ISO 1.4466, 1.4335, 1.4435, 1.4436, 1.4477, 1.4578 and 1.4585; UNS S31050, S31002, S31603 and S31600.

Specifications

Classifications	EN ISO 3581-A : E 25 22 2 N L B 12 SFA/AWS A5.4 : (E310Mo-15)
------------------------	--

Welding Current	DC+
Ferrite Content	FN 0
Alloy Type	25Cr 22Ni 2Mo N
Coating Type	Basic

Typical Tensile Properties

Condition	Yield Strength	Tensile Strength	Elongation
ISO			
As Welded	420 MPa	600 MPa	30 %

Typical Charpy V-Notch Properties

Condition	Testing Temperature	Impact Value
ISO		
As Welded	20 °C	70 J

Typical Weld Metal Analysis %

C	Mn	Si	S	P	Ni	Cr	Mo	Cu	N
<=0.04	4.5	0.4	<=0.020	<=0.020	22	25	2.1	0.05	0.14

Typical Weld Metal Analysis %

FN WRC-92
0

Deposition Data

Diameter	Current	Efficiency (%)	Fusion time per electrode at 90% I max	Deposition Rate
2.5 x 300 mm	60-80 A	-	-	0.0 kg/h
3.2 x 350 mm	80-110 A	64 %	55 sec	1.7 kg/h
4.0 x 350 mm	110-140 A	53 %	75 sec	2.3 kg/h

Exaton 27.31.4.LCuR



Exaton 27.31.4.LCuR is a covered electrode of AWS E383-17 type with rutile coating and normal metal recovery for welding of high-alloy austenitic stainless steels of UNS S08028 (e.g. Sanicro 28) and Alloy 825 type (e.g. Sanicro 41). Exaton 27.31.4.LCuR is suitable for joining highly alloyed fully austenitic stainless steels, such as EN 1.4563 (Sanicro 28) and Alloy 825 (Sanicro 41), which have high corrosion resistance in sulphuric and phosphoric acids and excellent pitting resistance in acid solutions containing chlorides and fluorides, such as sea water. This electrode can be used for surfacing mild and low alloy steels to give protection against pitting corrosion in chloride-containing solutions. Because the product is a bit sensitive for forming hotcracks, a correct welding practice is important.

Specifications

Classifications	EN ISO 3581-A : E 27 31 4 Cu L R SFA/AWS A5.4 : E383-17 Werkstoffnummer : 1.4563
Approvals	CE : EN 13749 UKCA : EN 13749

Approvals are based on factory location. Please contact ESAB for more information.

Welding Current	AC, DC+
Ferrite Content	FN 0
Alloy Type	Austenitic CrNiMo
Coating Type	Acid Rutile

Typical Tensile Properties

Condition	Yield Strength	Tensile Strength	Elongation
ISO			
As Welded	427 MPa	612 MPa	38 %

Typical Charpy V-Notch Properties

Condition	Testing Temperature	Impact Value
ISO		
As Welded	20 °C	66 J

Typical Weld Metal Analysis %

C	Mn	Si	S	P	Ni	Cr	Mo	Cu	N
<=0.025	0.90	0.8	0.006	0.018	32	27	3.5	0.9	0.07

Typical Weld Metal Analysis %

Co
0.060

Deposition Data

Diameter	Current	Voltage	Efficiency (%)	Fusion time per electrode at 90% I max	Deposition Rate
2.5 x 300 mm	40-95 A	30 V	60 %	33 sec	1.2 kg/h
3.2 x 350 mm	55-125 A	30 V	60 %	50 sec	1.6 kg/h
4.0 x 350 mm	70-185 A	31 V	61 %	48 sec	2.5 kg/h

OK Autrod 16.95

A continuous solid corrosion resisting chromium-nickel-manganese wire for welding of austenitic stainless alloys of 18% Cr, 8% Ni, 7% Mn types. OK Autrod 16.95 has a general corrosion resistance similar to that of the corresponding parent metal. The higher silicon content improves the welding properties, such as wetting. The product is a modified variant of ER307, basically with a higher Mn content to make the weld metal less sensitive to hot cracking. When used for joining dissimilar materials the corrosion resistance is of secondary importance. The alloy is used in a wide range of applications across the industry such as joining of austenitic, manganese, work hardenable steels as well as armourplate and heat resistant steels.

Specifications	
Classifications	EN ISO 14343-A : G 18 8 Mn SFA/AWS A5.9 : ER307 (mod) Werkstoffnummer : ~1.4370
Approvals	CE : EN 13479 DB : 43.039.10 UKCA : EN 13479 VdTUV : 05420

Approvals are based on factory location. Please contact ESAB for more information.

Alloy Type	Austenitic (18 % Cr - 8 % Ni - 7 % Mn)
Shielding Gas	M12, M13 (EN ISO 14175)

Typical Tensile Properties			
Condition	Yield Strength	Tensile Strength	Elongation
As Welded	450 MPa	640 MPa	41 %

Typical Charpy V-Notch Properties		
Condition	Testing Temperature	Impact Value
As Welded	20 °C	95 J

Typical Weld Metal Analysis %								
C	Mn	Si	S	P	Ni	Cr	Mo	Cu
0.1	6.5	1	0.020	0.010	8.0	18.5	0.1	0.1

Typical Wire Composition %							
C	Mn	Si	Ni	Cr	Mo	Cu	
0.08	7.0	0.9	8.1	18.7	0.20	0.10	

Deposition Data				
Diameter	Current	Voltage	Wire Feed Speed	Deposition Rate
0.8 mm	55-160 A	15-24 V	4.0-17.0 m/min	1.0-4.1 kg/h
0.9 mm	65-220 A	15-28 V	3.5-18.0 m/min	1.1-5.4 kg/h
1.0 mm	80-240 A	15-28 V	4.0-16.0 m/min	1.5-6.0 kg/h
1.2 mm	100-300 A	15-29 V	3.0-14.0 m/min	1.6-7.5 kg/h
1.6 mm	230-375 A	23-31 V	5.5-9.0 m/min	5.2-8.6 kg/h

OK Autrod 308H

A continuous solid corrosion resisting chromium-nickel wire for welding of austenitic chromium nickel alloys of 18% Cr - 8% Ni-type. OK Autrod 308H has a good general corrosion resistance. The alloy has a high carbon content which makes this alloy suitable for applications used at higher temperatures. The alloy is used in chemical and petrochemical plants for welding of pipes, cyclones and boilers.

Specifications

Classifications	EN ISO 14343-A : G 19 9 H SFA/AWS A5.9 : ER308H
Alloy Type	Austenitic 19% Cr - 9% Ni - High C
Shielding Gas	M12, M13 (EN ISO 14175)

Typical Wire Composition %

C	Mn	Si	Ni	Cr	N	Nb	FN WRC-92
0.05	1.9	0.5	9.2	19.8	0.06	0.01	9

Deposition Data

Diameter	Current	Voltage	Wire Feed Speed	Deposition Rate
0.8 mm	50-140 A	16-22 V	3.4-11.0 m/min	0.8-2.7 kg/h
1.0 mm	80-190 A	16-24 V	2.9-8.4 m/min	1.1-3.1 kg/h
1.2 mm	180-280 A	20-28 V	4.9-8.5 m/min	2.6-4.5 kg/h

OK Autrod 308L

A continuous solid corrosion resisting chromium-nickel wire. The alloy has a low carbon content which makes this alloy particularly recommended where there is a risk of intergranular corrosion. The alloy is widely used in the chemical and food processing industries as well as for pipes, tubes and boilers. For joining of stainless steels of 18% Cr - 8% Ni-type and Nb-stabilized steels of the same type if the service temperature will not exceed 350°C.

Specifications	
Classifications	EN ISO 14343-A : G 19 9 L SFA/AWS A5.9 : ER308L Werkstoffnummer : ~1.4316
Approvals	CE : EN 13479 UKCA : EN 13479

Approvals are based on factory location. Please contact ESAB for more information.

Alloy Type	Austenitic (with approx. 8 % ferrite) 19% Cr - 9% Ni - Low C
Shielding Gas	M12, M13 (EN ISO 14175)

Typical Tensile Properties			
Condition	Yield Strength	Tensile Strength	Elongation
As Welded	400 MPa	560 MPa	36 %

Typical Charpy V-Notch Properties		
Condition	Testing Temperature	Impact Value
As Welded	20 °C	95 J
As Welded	-60 °C	70 J
As Welded	-196 °C	35 J

Typical Weld Metal Analysis %									
C	Mn	Si	S	P	Ni	Cr	Mo	Cu	N
0.020	1.6	0.4	0.015	0.015	10.0	20.0	0.05	0.05	0.06

Typical Weld Metal Analysis %	
FN WRC-92	
11	

Typical Wire Composition %									
C	Mn	Si	S	P	Ni	Cr	Mo	Cu	N
0.02	1.9	0.4	0.012	0.016	9.8	19.8	0.20	0.15	0.05

Typical Wire Composition %	
Co	FN WRC-92
0.06	9

Deposition Data				
Diameter	Current	Voltage	Wire Feed Speed	Deposition Rate
0.9 mm	55-160 A	15-24 V	4.0-17.0 m/min	0.9-4.1 kg/h
1.0 mm	80-240 A	15-28 V	4.0-16.0 m/min	1.5-6.0 kg/h
1.2 mm	100-300 A	14-28.5 V	3.0-14.0 m/min	1.6-7.5 kg/h

OK Autrod 308LSi

A continuous solid corrosion resisting chromium-nickel wire for welding of austenitic chromium nickel alloys of 18% Cr - 8% Ni-type. OK Autrod 308LSi has a good general corrosion resistance. The alloy has a low carbon content which makes this alloy particularly recommended where there is a risk of intergranular corrosion. The higher silicon content improves the welding properties, such as wetting. The alloy is widely used in the chemical and food processing industries as well as for pipes, tubes and boilers.

Specifications

Classifications	EN ISO 14343-A : G 19 9 L Si SFA/AWS A5.9 : ER308LSi Werkstoffnummer : ~1.4316
Approvals	BV : 308L SA BT (M12) CE : EN 13479 CWB : ER308LSi DB : 43.039.01 DNV-GL : VL 308 L (M13) UKCA : EN 13479 VdTUV : 04267

Approvals are based on factory location. Please contact ESAB for more information.

Alloy Type	Austenitic (with approx. 8 % ferrite) 19% Cr - 9% Ni - Low C - High Si
Shielding Gas	M12, M13 (EN ISO 14175)

Typical Tensile Properties

Condition	Yield Strength	Tensile Strength	Elongation
EN ISO Tested at 350°C.			
As Welded	370 MPa	490 MPa	-
EN ISO			
As Welded	420 MPa	570 MPa	36 %

Typical Charpy V-Notch Properties

Condition	Testing Temperature	Impact Value
EN ISO		
As Welded	20 °C	105 J
As Welded	-60 °C	70 J
As Welded	-196 °C	40 J

Typical Weld Metal Analysis %

C	Mn	Si	S	P	Ni	Cr	Mo	Cu	N
0.03	1.8	0.7	0.009	0.020	10.0	19.5	0.03	0.1	0.04

Typical Weld Metal Analysis %

Nb	FN WRC-92
0.01	6

Typical Wire Composition %

C	Mn	Si	S	P	Ni	Cr	Mo	Cu	N
0.01	1.8	0.8	0.012	0.013	10.0	20.0	0.1	0.10	0.06

Typical Wire Composition %

Nb	FN WRC-92

OK Autrod 308LSi

Typical Wire Composition %

Nb	FN WRC-92
0.02	8

Deposition Data

Diameter	Current	Voltage	Wire Feed Speed	Deposition Rate
0.8 mm	55-160 A	15-24 V	4.0-17.0 m/min	1.0-4.1 kg/h
0.9 mm	65-220 A	15-28 V	3.5-18.0 m/min	1.1-5.4 kg/h
1.0 mm	80-240 A	15-28 V	4.0-16.0 m/min	1.5-6.0 kg/h
1.2 mm	100-300 A	15-29 V	3.0-14.0 m/min	1.6-7.5 kg/h
1.6 mm	230-375 A	23-29 V	5.5-9.0 m/min	5.2-8.6 kg/h

OK Autrod 309L

A continuous solid corrosion resisting chromium-nickel wire for welding of similar steels, wrought and cast steels of 23% Cr-12% Ni types. The alloy is also used for welding of buffer layers on CMn steels and welding of dissimilar joints. When using the wire for buffer layers and dissimilar joints it is necessary to control the dilution of the weld. OK Autrod 309L has a good general corrosion resistance. When used for joining dissimilar materials the corrosion resistance is of secondary importance.

Specifications

Classifications	EN ISO 14343-A : G 23 12 L SFA/AWS A5.9 : ER309L
Approvals	CE : EN 13479 UKCA : EN 13479

Approvals are based on factory location. Please contact ESAB for more information.

Alloy Type	Austenitic (with approx. 9 % ferrite) 24 % Cr - 13 % Ni - Low C
Shielding Gas	M12, M13 (EN ISO 14175)

Typical Tensile Properties

Condition	Yield Strength	Tensile Strength	Elongation
As Welded	440 MPa	600 MPa	32 %

Typical Charpy V-Notch Properties

Condition	Testing Temperature	Impact Value
As Welded	20 °C	160 J
As Welded	-60 °C	130 J
As Welded	-110 °C	90 J

Typical Weld Metal Analysis %

C	Mn	Si	S	P	Ni	Cr	Mo	Cu
0.03	1.5	0.4	0.005	0.010	12.5	23.5	0.1	0.1

Typical Wire Composition %

C	Mn	Si	S	P	Ni	Cr	Mo	Cu	N
0.02	1.8	0.4	0.010	0.015	13.4	23.2	0.10	0.1	0.05

Typical Wire Composition %

FN WRC-92
10

Deposition Data

Diameter	Current	Voltage	Wire Feed Speed	Deposition Rate
0.8 mm	55-160 A	15-24 V	4.0-17.0 m/min	1.0-4.1 kg/h
0.9 mm	65-220 A	15-28 V	3.5-18.0 m/min	1.1-5.4 kg/h
1.0 mm	80-240 A	15-28 V	4.0-16.0 m/min	1.5-6.0 kg/h
1.2 mm	100-300 A	15-29 V	3.0-14.0 m/min	1.6-7.5 kg/h

OK Autrod 309LSi

A continuous solid corrosion resistant chromium-nickel wire for welding of similar steels, wrought and cast steels of 23% Cr-12% Ni types. The alloy is also used for welding of buffer layers on CMn steels and welding of dissimilar joints. When using the wire for buffer layers and dissimilar joints it is necessary to control the dilution of the weld. OK Autrod 309LSi has a good general corrosion resistance. The higher silicon content improves the welding properties, such as wetting.

Specifications	
Classifications	EN ISO 14343-A : G 23 12 L Si SFA/AWS A5.9 : ER309LSi
Approvals	CE : EN 13479 CWB : ER309LSi DB : 43.039.16 UKCA : EN 13479 VdTÜV : 10020

Approvals are based on factory location. Please contact ESAB for more information.

Alloy Type	Austenitic (with approx. 8 % ferrite) 24 % Cr - 13 % Ni - Low C
Shielding Gas	M12, M13 (EN ISO 14175)

Typical Tensile Properties			
Condition	Yield Strength	Tensile Strength	Elongation
As Welded	440 MPa	600 MPa	35 %

Typical Charpy V-Notch Properties		
Condition	Testing Temperature	Impact Value
As Welded	20 °C	120 J
As Welded	-50 °C	110 J

Typical Weld Metal Analysis %									
C	Mn	Si	S	P	Ni	Cr	Mo	Cu	N
0.02	1.8	0.7	0.003	0.015	13.5	23	0.1	0.1	0.07

Typical Weld Metal Analysis %	
Nb	FN WRC-92
0.01	7

Typical Wire Composition %									
C	Mn	Si	S	P	Ni	Cr	Mo	Cu	N
0.016	1.9	0.7	0.004	0.019	13.7	23.3	0.1	0.1	0.09

Typical Wire Composition %
FN WRC-92
9

Deposition Data				
Diameter	Current	Voltage	Wire Feed Speed	Deposition Rate
0.8 mm	55-160 A	15-24 V	4.0-17.0 m/min	1.0-4.1 kg/h
0.9 mm	65-220 A	15-28 V	3.5-18.0 m/min	1.1-5.4 kg/h
1.0 mm	80-240 A	15-28 V	4.0-16.0 m/min	1.5-6.0 kg/h
1.2 mm	100-300 A	15-29 V	3.0-14.0 m/min	1.6-7.5 kg/h

OK Autrod 309MoL

A continuous solid corrosion resistant wire of 309LMo type. OK Autrod 309MoL is used for overlay welding of unalloyed and low alloyed steels and for welding of dissimilar steels such as 316L to unalloyed and low alloyed steels when Mo is essential.

Specifications	
Classifications	EN ISO 14343-A : G 23 12 2 L SFA/AWS A5.9 : ER 23 12 2 L SFA/AWS A5.9 : ER309LMo (mod)
Approvals	CE : EN 13479 UKCA : EN 13479 VdTUV : 07352

Approvals are based on factory location. Please contact ESAB for more information.

Alloy Type	Austenitic (with approx. 8 % ferrite) "309LMo" 22 % Cr - 15 % Ni - 3 % Mo - Low C
Shielding Gas	M12, M13 (EN ISO 14175)

Typical Tensile Properties			
Condition	Yield Strength	Tensile Strength	Elongation
As Welded	400 MPa	600 MPa	31 %

Typical Charpy V-Notch Properties		
Condition	Testing Temperature	Impact Value
As Welded	20 °C	95 J
As Welded	-60 °C	65 J

Typical Weld Metal Analysis %									
C	Mn	Si	S	P	Ni	Cr	Mo	Cu	N
0.02	1.3	0.3	0.002	0.02	14.5	21	2.6	0.1	0.07

Typical Weld Metal Analysis %	
Nb	FN WRC-92
0.01	8

Typical Wire Composition %					
C	Mn	Si	Ni	Cr	Mo
0.01	1.5	0.4	14.6	21.4	2.5

Deposition Data				
Diameter	Current	Voltage	Wire Feed Speed	Deposition Rate
0.8 mm	50-140 A	16-22 V	3.4-11.0 m/min	0.8-2.7 kg/h
1.0 mm	80-190 A	16-24 V	2.9-8.4 m/min	1.1-3.1 kg/h
1.2 mm	180-280 A	20-28 V	4.9-8.5 m/min	2.6-4.5 kg/h
1.6 mm	230-350 A	24-28 V	3.2-5.5 m/min	3.0-5.2 kg/h

OK Autrod 309Si

A continuous solid corrosion resisting chromium-nickel wire for joining stainless steels to non-alloy or low alloy steels as well as welding of austenitic stainless alloys of 24% Cr, 13% Ni, high C types. OK Autrod 309Si has a good general corrosion resistance. The higher silicon content improves the welding properties, such as wetting. When used for joining dissimilar materials the corrosion resistance is of secondary importance.

Specifications	
Classifications	EN ISO 14343-A : G 22 12 H SFA/AWS A5.9 : ER309Si
Approvals	CE : EN 13479 UKCA : EN 13479

Approvals are based on factory location. Please contact ESAB for more information.

Alloy Type	Austenitic (with approx. 10 % ferrite) 23 % Cr - 13 % Ni - High Si
Shielding Gas	M12, M13 (EN ISO 14175)

Typical Tensile Properties			
Condition	Yield Strength	Tensile Strength	Elongation
EN ISO			
As Welded	470 MPa	640 MPa	33 %

Typical Charpy V-Notch Properties		
Condition	Testing Temperature	Impact Value
EN ISO		
As Welded	20 °C	85 J
As Welded	-60 °C	60 J
As Welded	-110 °C	35 J

Typical Weld Metal Analysis %									
C	Mn	Si	S	P	Ni	Cr	Mo	Al	Cu
0.09	1.7	0.8	0.011	0.020	13	23	0	0	0

Typical Weld Metal Analysis %			
N	Nb	Ti	FN WRC-92
0	0	0	5

Typical Wire Composition %							
Mn	Si	S	P	Ni	Cr	Mo	Cu
1.7	0.9	0	0.020	12.7	23.5	0.2	0.15

Deposition Data				
Diameter	Current	Voltage	Wire Feed Speed	Deposition Rate
0.8 mm	50-140 A	16-22 V	3.4-11.0 m/min	0.8-2.7 kg/h
1.0 mm	80-190 A	16-24 V	2.9-8.4 m/min	1.1-3.1 kg/h
1.2 mm	180-280 A	20-28 V	4.9-8.5 m/min	2.6-4.5 kg/h
1.6 mm	230-350 A	24-28 V	3.2-5.5 m/min	3.0-5.2 kg/h

OK Autrod 310

A continuous solid corrosion resisting chromium-nickel wire for welding of heat resistant austenitic steels of the 25% Cr, 20% Ni types. OK Autrod 310 has a good general oxidation resistance especially at high temperatures due to its high Cr content. The alloy is fully austenitic and therefore sensitive to hot cracking. Common applications are industrial furnaces and boiler parts as well as heat exchangers.

Specifications	
Classifications	EN ISO 14343-A : G 25 20 SFA/AWS A5.9 : ER310
Approvals	CE : EN 13479 UKCA : EN 13479

Approvals are based on factory location. Please contact ESAB for more information.

Alloy Type	Fully austenitic (25 % Cr - 20 % Ni)
Shielding Gas	M12, M13 (EN ISO 14175)

Typical Tensile Properties			
Condition	Yield Strength	Tensile Strength	Elongation
As Welded	390 MPa	590 MPa	43 %

Typical Charpy V-Notch Properties		
Condition	Testing Temperature	Impact Value
As Welded	20 °C	175 J
As Welded	-196 °C	60 J

Typical Weld Metal Analysis %						
C	Mn	Si	S	P	Ni	Cr
0.10	1.7	0.4	0.015	0.010	20	25

Typical Wire Composition %								
C	Mn	Si	S	P	Ni	Cr	Mo	Cu
0.10	1.6	0.4	0.005	0.015	20.7	25.8	0.1	0.05

Deposition Data				
Diameter	Current	Voltage	Wire Feed Speed	Deposition Rate
0.8 mm	50-140 A	16-22 V	3.4-11.0 m/min	0.8-2.7 kg/h
1.0 mm	80-190 A	16-24 V	2.9-8.4 m/min	1.1-3.1 kg/h
1.2 mm	180-280 A	20-28 V	4.9-8.5 m/min	2.6-4.5 kg/h
1.6 mm	230-350 A	24-28 V	3.2-5.5 m/min	3.0-5.2 kg/h

OK Autrod 312

A continuous solid corrosion resisting chromium-nickel wire for welding of stainless steels of the 29% Cr, 9% Ni types. OK Autrod 312 has a good oxidation resistance at high temperatures due to its high content of Cr. The alloy is widely used for joining dissimilar steels especially if one of the component is fully austenitic and steels that are difficult to weld, i.e. machine components, tools, austenitic manganese steels.

Specifications

Classifications	EN ISO 14343-A : G 29 9 SFA/AWS A5.9 : ER312
------------------------	---

Alloy Type	Ferritic-austenitic (29 % Cr - 9 % Ni)
Shielding Gas	M12, M13 (EN ISO 14175)

Typical Tensile Properties

Condition	Yield Strength	Tensile Strength
As Welded	610 MPa	770 MPa

Typical Charpy V-Notch Properties

Condition	Testing Temperature	Impact Value
As Welded	20 °C	50 J

Typical Weld Metal Analysis %

C	Mn	Si	S	P	Ni	Cr
0.1	1.7	0.5	0.010	0.020	9	29

Typical Wire Composition %

C	Mn	Si	S	P	Ni	Cr	Mo	Cu	N
0.10	1.7	0.41	0.001	0.020	8.8	30.4	0.15	0.11	0.05

Deposition Data

Diameter	Current	Voltage	Wire Feed Speed	Deposition Rate
1.0 mm	80-190 A	16-24 V	2.9-8.4 m/min	1.1-3.1 kg/h
1.2 mm	180-280 A	20-28 V	4.9-8.5 m/min	2.6-4.5 kg/h

OK Autrod 316L

A continuous solid corrosion resisting chromium-nickel-molybdenum wire for welding of austenitic stainless alloys of 18% Cr - 8% Ni and 18% Cr - 10% Ni - 3% Mo types. OK Autrod 316L has a good general corrosion resistance, particularly against corrosion in acid and chlorinated environments. The alloy has a low carbon content which makes it particularly recommended where there is a risk of intergranular corrosion. The alloy is widely used in the chemical and food processing industries as well as in ship building and various types of architectural structures.

Specifications	
Classifications	EN ISO 14343-A : G 19 12 3 L SFA/AWS A5.9 : ER316L Werkstoffnummer : ~1.4430
Approvals	CE : EN 13479 UKCA : EN 13479

Approvals are based on factory location. Please contact ESAB for more information.

Alloy Type	Austenitic (with appr. 8 % ferrite) 19 % Cr - 12 % Ni - 3 % Mo - Low C
Shielding Gas	M12, M13 (EN ISO 14175)

Typical Tensile Properties			
Condition	Yield Strength	Tensile Strength	Elongation
As Welded	440 MPa	620 MPa	37 %
SHT 0.5 hour(s) 1050 °C	350 MPa	590 MPa	42 %
Tested at 350°C.			
As Welded	340 MPa	440 MPa	26 %
SHT 0.5 hour(s) 1050 °C	250 MPa	430 MPa	31 %

Typical Charpy V-Notch Properties		
Condition	Testing Temperature	Impact Value
SHT 0.5 hour(s) 1050 °C	20 °C	110 J
As Welded	20 °C	120 J
SHT 0.5 hour(s) 1050 °C	-60 °C	90 J
As Welded	-60 °C	95 J
SHT 0.5 hour(s) 1050 °C	-196 °C	50 J
As Welded	-196 °C	55 J

Typical Weld Metal Analysis %										
C	Mn	Si	S	P	Ni	Cr	Mo	Cu	N	
0.02	1.8	0.4	0.015	0.015	12	18.5	2.7	0.1	0.05	

Typical Weld Metal Analysis %										
FN WRC-92										
7										

Typical Wire Composition %										
C	Mn	Si	S	P	Ni	Cr	Mo	Cu	N	
0.01	1.7	0.4	0.010	0.015	12.0	18.2	2.6	0.10	0.04	

OK Autrod 316L

Typical Wire Composition %

FN WRC-92

7

Deposition Data

Diameter	Current	Voltage	Wire Feed Speed	Deposition Rate
0.8 mm	55-160 A	15-24 V	4.0-17.0 m/min	1.0-4.1 kg/h
0.9 mm	55-160 A	15-24 V	4.0-17.0 m/min	1.0-4.1 kg/h
1.0 mm	80-240 A	15-28 V	4.0-16.0 m/min	1.5-6.0 kg/h
1.14 mm	80-240 A	15-28 V	4.0-16.0 m/min	1.5-6.0 kg/h
1.2 mm	100-300 A	15-29 V	3.0-14.0 m/min	1.6-7.5 kg/h
1.6 mm	230-375 A	23-31 V	5.5-9.0 m/min	5.2-8.6 kg/h

OK Autrod 316LMn

OK Autrod 316LMn is a corrosion resistant non-magnetic chromium-nickel-molybdenum wire for welding of stabilized and non-stabilized austenitic stainless steels of the same type as well as non magnetic steels. The alloy is corrosion resistant in seawater environment and has very good corrosion resistance to acids, such as nitric acid. Excellent impact properties at low temperatures which makes it suitable for cryogenic applications.

Specifications

Classifications	EN ISO 14343-A : G 20 16 3 Mn N L SFA/AWS A5.9 : ER316LMn
Approvals	CE : EN 13479 UKCA : EN 13479

Approvals are based on factory location. Please contact ESAB for more information.

Alloy Type	Austenitic (7 % Mn - 20 % Cr - 16 % Ni - 3 % Mo)
Shielding Gas	M12, M13 (EN ISO 14175)

Typical Tensile Properties

Condition	Yield Strength	Tensile Strength	Elongation
As Welded	400 MPa	600 MPa	40 %

Typical Charpy V-Notch Properties

Condition	Testing Temperature	Impact Value
As Welded	-60 °C	90 J
As Welded	-110 °C	70 J
As Welded	-196 °C	40 J

Typical Weld Metal Analysis %

C	Mn	Si	S	P	Ni	Cr	Mo	Cu	N
0.02	7	0.3	0.01	0.01	16	20	3	0.05	0.15

Typical Wire Composition %

C	Mn	Si	Ni	Cr	Mo	N
0.01	6.9	0.4	15.6	19.9	3.0	0.18

Deposition Data

Diameter	Current	Voltage	Wire Feed Speed	Deposition Rate
1.0 mm	80-190 A	16-24 V	2.9-8.4 m/min	1.1-3.1 kg/h
1.2 mm	180-280 A	20-28 V	4.9-8.5 m/min	2.6-4.5 kg/h

OK Autrod 316LSi

A continuous solid corrosion resisting chromium-nickel-molybdenum wire for welding of austenitic stainless alloys of 18% Cr - 8% Ni and 18% Cr - 10% Ni - 3% Mo types. OK Autrod 316LSi has a good general corrosion resistance, in particularly the alloy has very good resistance against corrosion in acid and chlorinated environments. The alloy has a low carbon content which makes it particularly recommended where there is a risk of intergranular corrosion. The higher silicon content improves the welding properties, such as wetting. The alloy is widely used in the chemical and food processing industries as well as in ship building and various types of architectural structures.

Specifications	
Classifications	EN ISO 14343-A : G 19 12 3 L Si SFA/AWS A5.9 : ER316LSi Werkstoffnummer : ~1.4430
Approvals	ABS : ER316LSi CE : EN 13479 CWB : ER316LSi DB : 43.039.05 DNV-GL : VL 316 L (M13) DNV-GL : VL 316 L (M13) UKCA : EN 13479 VdTUV : 04268

Approvals are based on factory location. Please contact ESAB for more information.

Alloy Type	Austenitic (with approx. 8 % ferrite) 19% Cr - 12% Ni - 3% Mo - Low C - High Si
Shielding Gas	M12, M13 (EN ISO 14175)

Typical Tensile Properties			
Condition	Yield Strength	Tensile Strength	Elongation
As Welded	400 MPa	560 MPa	37 %
Tested at 350°C.			
As Welded	340 MPa	440 MPa	26 %

Typical Charpy V-Notch Properties		
Condition	Testing Temperature	Impact Value
As Welded	20 °C	120 J
As Welded	-60 °C	95 J
As Welded	-110 °C	70 J
As Welded	-196 °C	45 J

Typical Weld Metal Analysis %									
C	Mn	Si	S	P	Ni	Cr	Mo	Cu	FN WRC-92
0.02	1.8	0.8	0.015	0.015	12	18.5	2.7	0.1	6
-	-	-	-	-	-	-	-	-	6

Typical Wire Composition %							
C	Mn	Si	Ni	Cr	Mo	Cu	
0.01	1.8	0.9	12.2	18.4	2.60	0.12	

Deposition Data				
Diameter	Current	Voltage	Wire Feed Speed	Deposition Rate
0.8 mm	55-160 A	12-24 V	4.0-17.0 m/min	1.0-4.1 kg/h
0.9 mm	65-220 A	15-28 V	3.5-18.0 m/min	1.1-5.4 kg/h
1.0 mm	80-240 A	15-28 V	4.0-16.0 m/min	1.5-6.0 kg/h
1.2 mm	100-300 A	15-29 V	3.0-14.0 m/min	1.6-7.5 kg/h



OK Autrod 316LSi

Deposition Data

Diameter	Current	Voltage	Wire Feed Speed	Deposition Rate
1.6 mm	230-375 A	23-31 V	5.5-9.0 m/min	5.2-8.6 kg/h

OK Autrod 317L

A continuous solid corrosion resisting chromium-nickel-molybdenum wire for welding of austenitic stainless alloys of 19% Cr 13% Ni 3% Mo types. OK Autrod 317L has a good resistance to general corrosion and pitting due to its high content of molybdenum. The alloy has a low carbon content which makes this alloy particularly recommended where there is a risk of intergranular corrosion. The alloy is used in severe corrosion conditions such as in the petrochemical, pulp and paper industries.

Specifications

Classifications	EN ISO 14343-A : G 18 15 3 L SFA/AWS A5.9 : ER317L
------------------------	---

Typical Tensile Properties

Condition	Yield Strength	Tensile Strength	Elongation
As Welded	390 MPa	600 MPa	45 %

Typical Charpy V-Notch Properties

Condition	Testing Temperature	Impact Value
As Welded	20 °C	135 J
As Welded	-196 °C	55 J

Typical Wire Composition %

C	Mn	Si	S	P	Ni	Cr	Mo	Cu	N
0.01	1.4	0.4	0.009	0.02	13.7	19	3.6	0.11	0.05

Typical Wire Composition %

FN WRC-92

8

Deposition Data

Diameter	Current	Voltage	Wire Feed Speed	Deposition Rate
1.2 mm	180-280 A	20-28 V	4.9-8.5 m/min	2.6-4.5 kg/h

OK Autrod 318Si

A continuous solid corrosion resisting stabilized chromium-nickel-molybdenum wire for welding of Cr-Ni-Mo and Cr-Ni stabilized or non-stabilized steels. OK Autrod 318Si has a good general corrosion resistance. The alloy is stabilized with niobium to improve the resistance against intergranular corrosion of the weld metal. The higher silicon content improves the welding properties, such as wetting. Due to stabilization of niobium this alloy is recommended for service temperatures up to 400 °C.

Specifications	
Classifications	EN ISO 14343-A : G 19 12 3 Nb Si SFA/AWS A5.9 : ER318 (mod) Werkstoffnummer : ~1.4576
Approvals	CE : EN 13479 DB : 43.039.14 UKCA : EN 13479 VdTUV : 09735

Approvals are based on factory location. Please contact ESAB for more information.

Alloy Type	Austenitic (with approx. 7 % ferrite) 19% Cr - 12% Ni - 3 % Mo - Nb
Shielding Gas	M12, M13 (EN ISO 14175)

Typical Tensile Properties			
Condition	Yield Strength	Tensile Strength	Elongation
As Welded	460 MPa	615 MPa	35 %
Tested at 400°C.			
As Welded	400 MPa	540 MPa	35 %

Typical Charpy V-Notch Properties		
Condition	Testing Temperature	Impact Value
As Welded	20 °C	100 J
As Welded	-60 °C	70 J

Typical Weld Metal Analysis %									
C	Mn	Si	S	P	Ni	Cr	Mo	Cu	N
0.05	1.3	0.7	0.01	0.02	11.6	18.6	2.5	0.12	0.05

Typical Weld Metal Analysis %	
Nb	FN WRC-92
0.6	7

Typical Wire Composition %							
C	Mn	Si	Ni	Cr	Mo	Cu	Nb
0.05	1.7	0.8	11.9	18.8	2.60	0.10	0.50

Deposition Data				
Diameter	Current	Voltage	Wire Feed Speed	Deposition Rate
0.8 mm	55-160 A	15-24 V	4.0-17.0 m/min	1.0-4.1 kg/h
1.0 mm	80-240 A	15-28 V	4.0-16.0 m/min	1.5-6.0 kg/h
1.2 mm	100-300 A	15-29 V	3.0-14.0 m/min	1.6-7.5 kg/h

OK Autrod 347



OK Autrod 347 is suitable for joining stainless steels of the 18Cr/8Ni/Nb and 18Cr/8Ni/Ti types. Due to the strengthening effect of niobium, this grade is recommended if the weld metal will be exposed to temperatures above 400°C (750°F). It is used for joining and overlay welding with MIG/MAG, plasma and hot wire TIG and mechanized TIG.

Specifications

Classifications	EN ISO 14343-A : G 19 9 Nb SFA/AWS A5.9 : ER347 EN 10088-1 : ~1.4550
Approvals	CE : EN 13479 UKCA : EN 13479 VdTUV : 20080

Approvals are based on factory location. Please contact ESAB for more information.

Alloy Type	Austenitic (with approx. 8 % ferrite) 19% Cr - 9% Ni - Nb
Shielding Gas	M12, M13 (EN ISO 14175)

Typical Tensile Properties

Condition	Yield Strength	Tensile Strength	Elongation
As Welded 20 °C	470 MPa	650 MPa	35 %
As Welded+ 400 °C	380 MPa	500 MPa	26 %

Typical Charpy V-Notch Properties

Condition	Testing Temperature	Impact Value
As Welded	20 °C	90 J
As Welded	-196 °C	30 J

Typical Weld Metal Analysis %

C	Mn	Si	S	P	Ni	Cr	Mo	V	Al
0.06	1.5	0.4	0.012	0.016	9.2	19.2	0.1	0.06	0.003

Typical Weld Metal Analysis %

Cu	N	Nb	Ti	Co	FN WRC-92
0.1	0.04	0.7	0.003	0.1	9

Typical Wire Composition %

C	Mn	Si	S	P	Ni	Cr	Mo	V	Al
0.05	1.4	0.4	0.013	0.015	9.3	19.2	0.1	0.04	0.002

Typical Wire Composition %

Cu	N	Nb	Ti	Co	FN WRC-92
0.1	0.05	0.7	0.003	0.1	7

OK Autrod 347

Deposition Data					
Diameter	Current	Voltage	Efficiency (%)	Fusion time per electrode at 90% I max	Deposition Rate
2.5 x 350.0 mm	75-110 A	20 V	60 %	57 sec	0.9 kg/h
3.15 x 350.0 mm	110-150 A	24 V	67 %	74 sec	1.4 kg/h
4.0 x 450.0 mm	150-200 A	24 V	59 %	80 sec	1.7 kg/h
5.0 x 450.0 mm	190-275 A	23 V	66 %	80 sec	2.7 kg/h

Recommended Welding Parameters			
Wire Diameter	Current	Voltage	Wire Feed Speed
1.2 mm	150-260 A	24-29 V	3.0-10.0 mm/min

OK Autrod 347Si

OK Autrod 347Si is an austenitic stainless steel filler material for welding of stainless steel alloys of 18Cr/8Ni/Nb and 18Cr/8Ni/Ti types where good general corrosion resistance is required. The alloy is stabilized with Niobium to improve the resistance against intergranular corrosion of the weld metal. The higher silicon content improves the welding properties, such as wetting. Due to the niobium content the alloy is recommended for use at higher temperatures.

Specifications	
Classifications	EN ISO 14343-A : G 19 9 Nb Si SFA/AWS A5.9 : ER347Si Werkstoffnummer : ~1.4550
Approvals	CE : EN 13479 DB : 43.039.13 UKCA : EN 13479 VdTÜV : 09734

Approvals are based on factory location. Please contact ESAB for more information.

Alloy Type	Austenitic (with approx. 8 % ferrite) 19% Cr - 9% Ni - Nb
Shielding Gas	M12, M13 (EN ISO 14175)

Typical Tensile Properties			
Condition	Yield Strength	Tensile Strength	Elongation
EN M13			
As Welded	440 MPa	640 MPa	37 %
EN M13 Tested at 400°C.			
As Welded	340 MPa	460 MPa	26 %

Typical Charpy V-Notch Properties		
Condition	Testing Temperature	Impact Value
EN M13		
As Welded	20 °C	100 J
As Welded	-60 °C	70 J

Typical Weld Metal Analysis %									
C	Mn	Si	S	P	Ni	Cr	Mo	Cu	N
0.04	1.3	0.7	0.01	0.02	9.7	19	0.1	0.1	0.6

Typical Weld Metal Analysis %	
Nb	FN WRC-92
0.6	4

Typical Wire Composition %							
C	Mn	Si	Ni	Cr	Mo	Cu	Nb
0.04	1.7	0.7	9.8	19	0.1	0.10	0.60

Deposition Data				
Diameter	Current	Voltage	Wire Feed Speed	Deposition Rate
0.8 mm	55-160 A	15-24 V	4.0-17.0 m/min	1.0-4.1 kg/h
1.0 mm	80-240 A	15-28 V	3.5-18.0 m/min	1.5-6.0 kg/h
1.2 mm	100-300 A	15-29 V	3.0-14.0 m/min	1.6-7.5 kg/h
1.6 mm	230-375 A	23-31 V	5.5-9.0 m/min	5.2-8.6 kg/h

OK Autrod 410NiMo

A continuous solid welding wire of 12% Cr, 4.5% Ni, 0.5% Mo type. OK Autrod 410NiMo is used for welding of martensitic and martensitic-ferritic stainless steels in applications such as hydro turbines.

Specifications

Classifications	EN ISO 14343-A : G 13 4
Alloy Type	Martensitic-ferritic (12 % Cr - 4.5 % Ni - 0.5 % Mo)
Shielding Gas	M12, M13 (EN ISO 14175)

Typical Tensile Properties

Condition	Yield Strength	Tensile Strength	Elongation
As Welded	860 MPa	1050 MPa	13 %
Stress Relieved 2 hour(s) 600 °C	850 MPa	900 MPa	17 %
Stress Relieved 8 hour(s) 600 °C	750 MPa	850 MPa	20 %

Typical Charpy V-Notch Properties

Condition	Testing Temperature	Impact Value
As Welded	0 °C	35 J
Stress Relieved 2 hour(s) 600 °C	0 °C	70 J
Stress Relieved 8 hour(s) 600 °C	0 °C	75 J
As Welded	-20 °C	30 J
Stress Relieved 2 hour(s) 600 °C	-20 °C	55 J
Stress Relieved 8 hour(s) 600 °C	-20 °C	75 J

Typical Weld Metal Analysis %

C	Mn	Si	S	P	Ni	Cr	Mo	Cu
0.02	0.38	0.37	0.003	0.019	4.5	12	0.4	0.1

Typical Wire Composition %

C	Mn	Si	S	P	Ni	Cr	Mo	Cu
0.02	0.43	0.37	0.004	0.017	4.5	12.2	0.4	0.07

Deposition Data

Diameter	Current	Voltage	Wire Feed Speed	Deposition Rate
1.2 mm	180-280 A	20-28 V	4.9-8.5 m/min	2.6-4.5 kg/h

OK Autrod 430LNb

A continuous ferritic stainless solid wire with low carbon content, 18 % Cr and stabilized with Nb, for welding similar and matching steels. OK Autrod 430LNb is developed and designed for the Automotive industry and used for production of exhaust systems. The wire should be used when there is a need for good resistance to corrosion and thermal fatigue.

Specifications	
Classifications	EN ISO 14343-A : G 18 L Nb Werkstoffnummer : ~1.4511
Approvals	CE : EN 13479 UKCA : EN 13479

Approvals are based on factory location. Please contact ESAB for more information.

Alloy Type	18 % Cr - 0.5 % Nb
Shielding Gas	M12, M13 (EN ISO 14175)

Typical Tensile Properties			
Condition	Yield Strength	Tensile Strength	Elongation
As Welded	275 MPa	420 MPa	26 %

Typical Weld Metal Analysis %									
C	Mn	Si	S	P	Ni	Cr	Mo	Cu	N
0.015	0.50	0.50	0.003	0.015	0.2	18.5	0.06	0.10	0.01

Typical Weld Metal Analysis %
Nb
0.45

Typical Wire Composition %							
C	Mn	Si	Ni	Cr	Mo	Cu	Nb
0.01	0.5	0.5	0.2	18.5	0.06	0.10	0.45

Deposition Data					
Diameter	Current	Voltage	Wire Feed Speed	Deposition Rate	
0.8 mm	50-140 A	16-22 V	3.4-11.0 m/min	0.8-2.7 kg/h	
1.0 mm	80-190 A	16-24 V	2.9-8.4 m/min	1.1-3.1 kg/h	
1.2 mm	180-280 A	20-28 V	4.9-8.5 m/min	2.6-4.5 kg/h	

OK Autrod 430LNbTi

A ferritic stainless solid wire with low carbon content and excellent welding properties, 18 % Cr and stabilized with Nb and Ti, for welding similar and matching steels. OK Autrod 430LNbTi is developed and designed for the Automotive industry and used for production of exhaust systems. The wire should be used when there is a need for very good resistance to corrosion and thermal fatigue.

Specifications	
Classifications	EN ISO 14343-A : G 18 L Nb Ti Werkstoffnummer : ~1.4509
Approvals	CE : EN 13479 UKCA : EN 13479

Approvals are based on factory location. Please contact ESAB for more information.

Alloy Type	18 % Cr – Nb and Ti stabilized
Shielding Gas	M12, M13 (EN ISO 14175)

Typical Wire Composition %									
C	Mn	Si	S	P	Ni	Cr	Mo	Cu	N
0.01	0.5	0.5	0.005	0.020	0.2	18.5	0.06	0.10	0.017

Typical Wire Composition %	
Nb	Ti
0.5	0.30

Deposition Data				
Diameter	Current	Voltage	Wire Feed Speed	Deposition Rate
1.0 mm	80-190 A	16-24 V	2.9-8.4 m/min	1.1-3.1 kg/h
1.2 mm	180-280 A	20-28 V	4.9-8.5 m/min	2.6-4.5 kg/h

OK Autrod 2209

A continuous solid corrosion resisting Duplex wire for welding of austenitic-ferritic stainless alloys of 22% Cr, 5% Ni, 3% Mo types. OK Autrod 2209 has a high general corrosion resistance. In media containing chloride and hydrogen sulphide the alloy has a high resistance to intergranular, pitting and especially to stress corrosion. The alloy is used in a variety of applications across all industrial segments.

Specifications	
Classifications	EN ISO 14343-A : G 22 9 3 N L SFA/AWS A5.9 : ER2209
Approvals	CE : EN 13479 DB : 43.039.18 DNV-GL : Duplex UKCA : EN 13479 VdTÜV : 13039*

Approvals are based on factory location. Please contact ESAB for more information.

Alloy Type	Austenitic-ferritic (22.5 % Cr - 8 % Ni - 3 % Mo - Low C)
Shielding Gas	M12, M13 (EN ISO 14175)

Typical Tensile Properties			
Condition	Yield Strength	Tensile Strength	Elongation
AWS 98 Ar/2 O2 (M13)			
As Welded	590 MPa	785 MPa	31 %
EN 98 Ar/2 O2 (M13)			
As Welded	610 MPa	785 MPa	32 %

Typical Charpy V-Notch Properties		
Condition	Testing Temperature	Impact Value
AWS 98 Ar/2 O2 (M13)		
As Welded	-30 °C	105 J
As Welded	-46 °C	90 J
EN 98 Ar/2 O2 (M13)		
As Welded	-30 °C	95 J
As Welded	-46 °C	90 J

Typical Weld Metal Analysis %									
C	Mn	Si	S	P	Ni	Cr	Mo	N	Nb
0.01	1.6	0.6	0.01	0.01	9	23	3	0.1	0.01

Typical Weld Metal Analysis %	
PRE	FN WRC-92
35	50

Typical Wire Composition %								
C	Mn	Si	Ni	Cr	Mo	N	PRE	FN WRC-92
0.01	1.5	0.5	8.5	22.7	3.2	0.17	35	55

Deposition Data				
Diameter	Current	Voltage	Wire Feed Speed	Deposition Rate
0.8 mm	50-140 A	16-22 V	3.4-11.0 m/min	0.8-2.7 kg/h
1.0 mm	80-190 A	16-24 V	2.9-8.4 m/min	1.1-3.1 kg/h

OK Autrod 2209

Deposition Data

Diameter	Current	Voltage	Wire Feed Speed	Deposition Rate
1.2 mm	180-280 A	20-28 V	4.9-8.5 m/min	2.6-4.5 kg/h
1.6 mm	230-350 A	24-28 V	3.2-5.5 m/min	3.0-5.2 kg/h

OK Autrod 2504

A ferritic stainless steel solid wire with approximately 15 % austenite, high carbon content and 25 % Cr for welding similar and matching heat resistant ferritic-austenitic and ferritic steels. OK Autrod 2504 is developed and designed for the automotive industry and used for production of exhaust systems where oxidizing and sulfur containing combustion gases are expected. The wire has excellent welding properties and should be used when there is a need for very good resistance to corrosion and thermal fatigue. Resistant to scaling up to 1100°C. OK Autrod 2504 is suitable to use when welding base material 1.4821 / X15CrNiSi25-4; 1.4823 / GX40CrNiSi27-4 1.4713 / X10CrAlSi7; 1.4724 / X10CrAlSi13; 1.4742 / X10CrAlSi18; 1.4762 / X10CrAlSi25; 1.4710 / GX30CrSi7; 1.4740 / GX40CrSi17; ASTM A 297 Gr. HC, HD; AISI 327.

Specifications	
Classifications	EN ISO 14343-A : G 25 4 Werkstoffnummer : ~1.4820
Approvals	CE : EN 13479 UKCA : EN 13479

Approvals are based on factory location. Please contact ESAB for more information.

Alloy Type	Ferritic (with ~15 austenite) 25 % Cr - 4 % Ni - High C
Shielding Gas	M12 (EN ISO 14175)

Typical Tensile Properties			
Condition	Yield Strength	Tensile Strength	Elongation
As Welded	570 MPa	680 MPa	20 %

Typical Charpy V-Notch Properties		
Condition	Testing Temperature	Impact Value
As Welded	20 °C	60 J
As Welded	-20 °C	20 J

Typical Weld Metal Analysis %									
C	Mn	Si	S	P	Ni	Cr	Mo	Cu	N
0.07	1.1	0.6	0.004	0.019	4.4	25.1	0.1	0.08	0.07

Typical Weld Metal Analysis %		
Nb	Co	PRE
0.01	0.05	26.5

Typical Wire Composition %									
C	Mn	Si	S	P	Ni	Cr	Mo	Al	Cu
0.07	1.1	0.65	0.005	0.019	4.4	25.1	0.1	0.001	0.08

Typical Wire Composition %				
N	Nb	Ti	Co	PRE
0.06	0.01	0.001	0.05	26.5

Deposition Data				
Diameter	Current	Voltage	Wire Feed Speed	Deposition Rate
1.0 mm	80-190 A	16-24 V	2.9-8.4 m/min	1.1-3.1 kg/h

OK Autrod 2509

A continuous solid corrosion resisting "Super Duplex" wire for welding of austenitic-ferritic stainless alloys of 25% Cr, 7% Ni, 4% Mo, low C types. OK Autrod 2509 has high intergranular, pitting and stress corrosion resistance. The alloy is widely used in applications where corrosion resistance is of utmost importance. Pulp & paper industry, offshore and gas industry are areas of interest.

Specifications	
Classifications	EN ISO 14343-A : G 25 9 4 N L SFA/AWS A5.9 : ER2594
Approvals	CE : EN 13479 NAKS/HAKC : 1.0 mm UKCA : EN 13479

Approvals are based on factory location. Please contact ESAB for more information.

Alloy Type	Austenitic-ferritic (25 % Cr - 10 % Ni - 4 % Mo - Low C)
Shielding Gas	M12, M13 (EN ISO 14175)

Typical Tensile Properties			
Condition	Yield Strength	Tensile Strength	Elongation
As Welded	659 MPa	832 MPa	30 %

Typical Charpy V-Notch Properties		
Condition	Testing Temperature	Impact Value
As Welded	20 °C	159 J
As Welded	-40 °C	129 J

Typical Weld Metal Analysis %									
C	Mn	Si	S	P	Ni	Cr	Mo	Cu	N
0.01	0.3	0.4	0.001	0.02	9.2	25	4	0.1	0.25

Typical Weld Metal Analysis %		
Nb	PRE	FN WRC-92
0.01	41.5	50

Typical Wire Composition %									
C	Mn	Si	Ni	Cr	Mo	N	PRE	FN WRC-92	
0.01	0.4	0.4	9.4	25.2	3.9	0.24	42	50	

Deposition Data				
Diameter	Current	Voltage	Wire Feed Speed	Deposition Rate
1.0 mm	80-190 A	16-24 V	2.9-8.4 m/min	1.1-3.1 kg/h
1.2 mm	180-280 A	20-28 V	4.9-8.5 m/min	2.6-4.5 kg/h

OK Tigrod 16.95

Bare corrosion resisting chromium-nickel-manganese welding rods for welding of austenitic stainless alloys of 18% Cr, 8% Ni, 7% Mn types. OK Tigrod 16.95 has a general corrosion resistance similar to that of the corresponding parent metal. The higher silicon content improves the welding properties, such as wetting. When used for joining dissimilar materials the corrosion resistance is of secondary importance. The alloy is used in a wide range of applications across the industry such as joining of austenitic, manganese, work hardenable steels as well as armourplate and heat resistant steels.

Specifications	
Classifications	EN ISO 14343-A : W 18 8 Mn SFA/AWS A5.9 : ER307 (mod) Werkstoffnummer : ~1.4370
Approvals	CE : EN 13479 DB : 43.039.12 UKCA : EN 13479 VdTUV : 05421

Approvals are based on factory location. Please contact ESAB for more information.

Alloy Type	Austenitic (18 % Cr - 8 % Ni - 7 % Mn)
Shielding Gas	11 (EN ISO 14175)

Typical Tensile Properties			
Condition	Yield Strength	Tensile Strength	Elongation
As Welded	450 MPa	640 MPa	41 %

Typical Charpy V-Notch Properties		
Condition	Testing Temperature	Impact Value
As Welded	20 °C	130 J
As Welded	-60 °C	56 J

Typical Weld Metal Analysis %								
C	Mn	Si	S	P	Ni	Cr	Mo	Cu
0.08	6.5	0.7	0.020	0.010	8.5	18.5	0.1	0.1

Typical Wire Composition %						
C	Mn	Si	Ni	Cr	Mo	Cu
0.08	7.0	0.9	8.1	18.7	0.20	0.10

OK Tigrod 308H

Bare corrosion resisting chromium-nickel rods for welding of austenitic chromium nickel alloys of 18 % Cr - 8 % Ni-type. OK Tigrod 308H has a good general corrosion resistance. The alloy has a high carbon content which makes this alloy suitable for applications used at higher temperatures. The alloy is used in chemical and petrochemical industry for welding of for tubes, cyclones and boilers.

Specifications

Classifications	EN ISO 14343-A : W 19 9 H SFA/AWS A5.9 : ER308H
Alloy Type	Austenitic 19% Cr - 9% Ni - High C
Shielding Gas	I1 (EN ISO 14175)

Typical Tensile Properties

Condition	Yield Strength	Tensile Strength	Elongation
As Welded	507 MPa	660 MPa	39 %

Typical Charpy V-Notch Properties

Condition	Testing Temperature	Impact Value
As Welded	-18 °C	157 J

Typical Wire Composition %

C	Mn	Si	Ni	Cr	N	Nb	FN WRC-92
0.05	1.9	0.5	9.2	19.8	0.06	0.01	9

OK Tigrod 308L

Bare corrosion resisting chromium-nickel rods. OK Tigrod 308L has a good general corrosion resistance. The alloy has a low carbon content which makes this alloy particularly recommended where there is a risk of intergranular corrosion. The alloy is widely used in the chemical and food processing industries as well as for pipes, tubes and boilers. For joining of stainless steels of 18% Cr - 8% Ni-type with low carbon content and Nb-stabilized steels of the same type if the service temperature will not exceed 350°C. Can also be used for welding of Cr-steels except in sulphur rich environments.

Specifications

Classifications	EN ISO 14343-A : W 19 9 L SFA/AWS A5.9 : ER308L Werkstoffnummer : ~1.4316
Approvals	CE : EN 13479 CWB : ER308L DNV-GL : VL 308 L UKCA : EN 13479 VdTÜV : 04269

Approvals are based on factory location. Please contact ESAB for more information.

Alloy Type	Austenitic (with approx. 8 % ferrite) 19% Cr - 9% Ni - Low C
Shielding Gas	I1 (EN ISO 14175)

Typical Tensile Properties

Condition	Yield Strength	Tensile Strength	Elongation
As Welded	440 MPa	580 MPa	36 %

Typical Charpy V-Notch Properties

Condition	Testing Temperature	Impact Value
As Welded	20 °C	170 J
As Welded	-80 °C	135 J
As Welded	-196 °C	80 J

Typical Weld Metal Analysis %

C	Mn	Si	S	P	Ni	Cr	Mo	Cu	N
0.01	1.8	0.4	0.015	0.020	10	20	0.1	0.1	0.07

Typical Weld Metal Analysis %

Co	FN WRC-92
0.06	10

Typical Wire Composition %

C	Mn	Si	S	P	Ni	Cr	Mo	Cu	N
0.02	1.9	0.4	0.012	0.016	9.8	19.8	0.20	0.15	0.05

Typical Wire Composition %

Co	FN WRC-92
0.06	9

OK Tigrod 308LSi

Bare corrosion resisting chromium-nickel rods for welding of austenitic chromium nickel alloys of 18% Cr 8% Ni-type. OK Tigrod 308LSi has a good general corrosion resistance. The alloy has a low carbon content which makes this alloy particularly recommended where there is a risk of intergranular corrosion. The higher silicon content improves the welding properties, such as wetting. The alloy is widely used in the chemical and food processing industries as well as for pipes, tubes and boilers.

Specifications	
Classifications	EN ISO 14343-A : W 19 9 L Si SFA/AWS A5.9 : ER308LSi Werkstoffnummer : ~1.4316
Approvals	BV : 308L BT CE : EN 13479 DB : 43.039.11 DNV-GL : VL 308 L (I1) UKCA : EN 13479 VdTÜV : 05335

Approvals are based on factory location. Please contact ESAB for more information.

Alloy Type	Austenitic (with approx. 8 % ferrite) 19% Cr - 9% Ni - Low C
Shielding Gas	I1 (EN ISO 14175)

Typical Tensile Properties			
Condition	Yield Strength	Tensile Strength	Elongation
As Welded	480 MPa	635 MPa	37 %

Typical Charpy V-Notch Properties		
Condition	Testing Temperature	Impact Value
As Welded	20 °C	170 J
As Welded	-60 °C	150 J
As Welded	-110 °C	140 J
As Welded	-196 °C	75 J

Typical Weld Metal Analysis %									
C	Mn	Si	S	P	Ni	Cr	Mo	Cu	N
0.01	1.8	0.7	0.01	0.02	10	20	0.1	0.1	0.07

Typical Weld Metal Analysis %	
Nb	FN WRC-92
0.1	8

Typical Wire Composition %									
C	Mn	Si	S	P	Ni	Cr	Mo	Cu	N
0.01	1.8	0.8	0.012	0.013	10.0	20.0	0.1	0.10	0.06

Typical Wire Composition %	
Nb	FN WRC-92
0.02	8

OK Tigrod 309L

Bare corrosion resisting chromium-nickel welding rod for welding of similar steels of 24% Cr, 13% Ni types. The alloy is also used for welding of buffer layers on CMn steels and welding of dissimilar joints. When using the wire for buffer layers and dissimilar joints it is necessary to control the dilution of the weld. OK Tigrod 309L has a good general corrosion resistance. When used for joining dissimilar materials the corrosion resistance is of secondary importance.

Specifications	
Classifications	EN ISO 14343-A : W 23 12 L SFA/AWS A5.9 : ER309L
Approvals	CE : EN 13479 CWB : ER309L UKCA : EN 13479 VdTÜV : 10021

Approvals are based on factory location. Please contact ESAB for more information.

Alloy Type	Austenitic (with approx. 10 % ferrite) 24 % Cr - 13 % Ni - Low C
Shielding Gas	I1 (EN ISO 14175)

Typical Tensile Properties			
Condition	Yield Strength	Tensile Strength	Elongation
As Welded	430 MPa	590 MPa	32 %

Typical Charpy V-Notch Properties		
Condition	Testing Temperature	Impact Value
As Welded	20 °C	160 J
As Welded	-60 °C	130 J
As Welded	-110 °C	90 J

Typical Weld Metal Analysis %									
C	Mn	Si	S	P	Ni	Cr	Mo	Cu	N
0.015	1.7	0.4	0.015	0.020	13.0	24.0	0.1	0.1	0.08

Typical Weld Metal Analysis %									
FN WRC-92									
12									

Typical Wire Composition %									
C	Mn	Si	S	P	Ni	Cr	Mo	Cu	N
0.02	1.8	0.4	0.010	0.015	13.4	23.2	0.10	0.1	0.05

Typical Wire Composition %									
FN WRC-92									
10									

OK Tigrod 309LSi

Bare corrosion resistant chromium-nickel welding rod for welding of similar steels, wrought and cast steels of 23% Cr-12% Ni types. The alloy is also used for welding of buffer layers on CMn steels and welding of dissimilar joints. When using the wire for buffer layers and dissimilar joints it is necessary to control the dilution of the weld. OK Tigrod 309LSi has a good general corrosion resistance. The higher silicon content improves the welding properties, such as wetting.

Specifications	
Classifications	EN ISO 14343-A : W 23 12 L Si SFA/AWS A5.9 : ER309LSi
Approvals	CE : EN 13479 DB : 43.039.17 UKCA : EN 13479 VdTÜV : 12489

Approvals are based on factory location. Please contact ESAB for more information.

Alloy Type	Austenitic (with approx. 8 % ferrite) 24 % Cr - 13 % Ni - Low C
Shielding Gas	I1 (EN ISO 14175)

Typical Tensile Properties			
Condition	Yield Strength	Tensile Strength	Elongation
As Welded	475 MPa	610 MPa	35 %

Typical Charpy V-Notch Properties		
Condition	Testing Temperature	Impact Value
As Welded	20 °C	185 J
As Welded	0 °C	155 J
As Welded	-110 °C	130 J

Typical Weld Metal Analysis %									
C	Mn	Si	S	P	Ni	Cr	Mo	Cu	N
0.01	1.8	0.7	0.003	0.015	13.5	23	0.1	0.1	0.09

Typical Weld Metal Analysis %	
Nb	FN WRC-92
0.01	8

Typical Wire Composition %									
C	Mn	Si	S	P	Ni	Cr	Mo	Cu	N
0.016	1.9	0.7	0.004	0.019	13.7	23.3	0.1	0.1	0.09

Typical Wire Composition %
FN WRC-92
9

OK Tigrod 309MoL

A continuous solid corrosion resistant wire of 309LMo type. OK Tigrod 309MoL is used for overlay welding of unalloyed and low alloyed steels and for welding of dissimilar steels such as 316L to unalloyed and low alloyed steels when Mo is essential

Specifications	
Classifications	EN ISO 14343-A : W 23 12 2 L SFA/AWS A5.9 : ER 23 12 2 L SFA/AWS A5.9 : ER309LMo (mod)
Approvals	CE : EN 13479 DNV-GL : 1.6-3.2mm UKCA : EN 13479

Approvals are based on factory location. Please contact ESAB for more information.

Alloy Type	Austenitic (with approx. 8% ferrite) "309LMo", 22 % Cr - 15 % Ni - 3 % Mo - Low C
Shielding Gas	I1 (EN ISO 14175)

Typical Tensile Properties			
Condition	Yield Strength	Tensile Strength	Elongation
EN ISO I1			
As Welded	510 MPa	630 MPa	26 %
AWS I1			
As Welded	490 MPa	640 MPa	33 %

Typical Charpy V-Notch Properties		
Condition	Testing Temperature	Impact Value
EN ISO I1		
As Welded	20 °C	90 J
AWS I1		
As Welded	20 °C	130 J
As Welded	-60 °C	65 J

Typical Weld Metal Analysis %									
C	Mn	Si	S	P	Ni	Cr	Mo	V	Cu
0.01	1.4	0.30	0.002	0.02	14.6	21.1	2.6	0.05	0.1

Typical Weld Metal Analysis %			
N	Nb	Co	FN WRC-92
0.06	0.01	0.05	9

Typical Wire Composition %					
C	Mn	Si	Ni	Cr	Mo
0.01	1.5	0.4	14.6	21.4	2.5

OK Tigrod 310

Bare corrosion resisting chromium-nickel welding rod for welding of heat resistant austenitic steels of the 25Cr-20Ni-type. The wire has a high Cr content and gives good oxidation resistance at high temperatures. Common applications are industrial furnaces and boiler parts as well as heat exchangers.

Specifications

Classifications	EN ISO 14343-A : W 25 20 SFA/AWS A5.9 : ER310
Approvals	CE : 13479 UKCA : 13479

Approvals are based on factory location. Please contact ESAB for more information.

Alloy Type	Fully austenitic (25 % Cr - 20 % Ni)
Shielding Gas	I1, I2, I3 (EN ISO 14175)

Typical Tensile Properties

Condition	Yield Strength	Tensile Strength	Elongation
As Welded	420 MPa	560 MPa	30 %

Typical Charpy V-Notch Properties

Condition	Testing Temperature	Impact Value
As Welded	20 °C	230 J
As Welded	-196 °C	130 J

Typical Weld Metal Analysis %

C	Mn	Si	S	P	Ni	Cr	Mo	Cu
0.10	1.7	0.35	0.001	0.014	20.8	25.6	0.03	0.01

Typical Wire Composition %

C	Mn	Si	S	P	Ni	Cr	Mo	Cu
0.10	1.68	0.38	0.001	0.016	20.8	25.8	0.07	0.08

OK Tigrod 312

Bare corrosion resisting chromium-nickel welding rods for welding of materials of the 29% Cr, 9% Ni types. OK Tigrod 312 has a good oxidation resistance at high temperatures due to its high content of Cr. The alloy is widely used for joining dissimilar steels especially if one of the component is fully austenitic and steels that are difficult to weld, i.e. machine components, tools and austenitic manganese steels.

Specifications

Classifications	EN ISO 14343-A : W 29 9 SFA/AWS A5.9 : ER312
Approvals	CE : EN 13479 UKCA : EN 13479

Approvals are based on factory location. Please contact ESAB for more information.

Alloy Type	Ferritic-austenitic (29 % Cr - 9 % Ni)
Shielding Gas	11, 12, 13 (EN ISO 14175)

Typical Tensile Properties

Condition	Yield Strength	Tensile Strength
ISO		
As Welded	610 MPa	770 MPa

Typical Charpy V-Notch Properties

Condition	Testing Temperature	Impact Value
AWS		
As Welded	20 °C	50 J

Typical Weld Metal Analysis %

C	Mn	Si	S	P	Ni	Cr
0.1	1.7	0.5	0.010	0.020	9	29

Typical Wire Composition %

C	Mn	Si	S	P	Ni	Cr	Mo	Cu	N
0.10	1.7	0.41	0.001	0.020	8.8	30.4	0.15	0.11	0.05

OK Tigrod 316L

Bare corrosion resisting chromium-nickel-molybdenum welding rods for welding of austenitic stainless alloys of 18% Cr - 8% Ni and 18% Cr - 10% Ni - 3% Mo types. OK Tigrod 316L has a good general corrosion resistance, particularly against corrosion in acid and chlorinated environments. The alloy has a low carbon content which makes it particularly recommended where there is a risk of intergranular corrosion. The alloy is widely used in the chemical and food processing industries as well as in ship building and various types of architectural structures.

Specifications	
Classifications	EN ISO 14343-A : W 19 12 3 L SFA/AWS A5.9 : ER316L Werkstoffnummer : ~1.4430
Approvals	ABS : 1.6-3.2mm BV : 1.6-3.2mm CE : EN 13479 CWB : ER316L DNV : 1.0-4.0mm RINA : 316L BT UKCA : EN 13479 VdTÜV : 1.0-4.0mm

Approvals are based on factory location. Please contact ESAB for more information.

Alloy Type	Austenitic (with approx. 10 % ferrite) 19% Cr - 12% Ni - 3% Mo - Low C
Shielding Gas	I1 (EN ISO 14175)

Typical Tensile Properties			
Condition	Yield Strength	Tensile Strength	Elongation
As Welded	470 MPa	600 MPa	32 %

Typical Charpy V-Notch Properties		
Condition	Testing Temperature	Impact Value
As Welded	20 °C	175 J
As Welded	-60 °C	130 J
As Welded	-110 °C	120 J
As Welded	-196 °C	75 J

Typical Weld Metal Analysis %									
C	Mn	Si	S	P	Ni	Cr	Mo	Cu	N
0.01	1.8	0.4	0.01	0.02	12	19	2.6	0.1	0.05

Typical Weld Metal Analysis %									
FN WRC-92									
7									

Typical Wire Composition %									
C	Mn	Si	S	P	Ni	Cr	Mo	Cu	N
0.01	1.7	0.4	0.010	0.015	12.0	18.2	2.6	0.10	0.04

Typical Wire Composition %									
FN WRC-92									
7									

OK Tigrod 316LSi

Bare corrosion resisting chromium-nickel-molybdenum rods for welding of austenitic stainless alloys of 18% Cr-8% Ni and 18% Cr-10% Ni-3% Mo types. OK Tigrod 316LSi has a good general corrosion resistance, in particular the alloy has very good resistance against corrosion in acid and chlorinated environments. The alloy has a low carbon content which makes it particularly recommended where there is a risk of intergranular corrosion. The higher silicon content improves the welding properties, such as wetting. The alloy is widely used in the chemical and food processing industries as well as in ship building and various types of architectural structures.

Specifications	
Classifications	EN ISO 14343-A : W 19 12 3 L Si SFA/AWS A5.9 : ER316LSi Werkstoffnummer : ~1.4430
Approvals	BV : 316L BT CE : EN 13479 DB : 43.039.06 DNV-GL : VL 316 L (I1) UKCA : EN 13479 VdTÜV : 05336

Approvals are based on factory location. Please contact ESAB for more information.

Alloy Type	Austenitic (with approx. 8 % ferrite) 19% Cr - 12% Ni - 3% Mo - Low C- High Si
Shielding Gas	I1 (EN ISO 14175)

Typical Tensile Properties			
Condition	Yield Strength	Tensile Strength	Elongation
As Welded	500 MPa	630 MPa	33 %

Typical Charpy V-Notch Properties		
Condition	Testing Temperature	Impact Value
As Welded	20 °C	175 J
As Welded	-110 °C	110 J
As Welded	-196 °C	90 J

Typical Weld Metal Analysis %									
C	Mn	Si	S	P	Ni	Cr	Mo	Cu	N
Shielding gas;Ar									
0.01	1.8	0.8	0.01	0.02	12	18	2.8	0.1	0.06

Typical Weld Metal Analysis %									
FN WRC-92									
Shielding gas;Ar									
7									

Typical Wire Composition %						
C	Mn	Si	Ni	Cr	Mo	Cu
0.01	1.8	0.9	12.2	18.4	2.60	0.12

OK Tigrod 317L

Bare corrosion resisting chromium-nickel-molybdenum welding rods for welding of austenitic stainless alloys of 19% Cr 9% Ni 3% Mo types. OK Tigrod 317L has a good resistance to general corrosion and pitting due to its high content of molybdenum. The alloy has a low carbon content which makes this alloy particularly recommended where there is a risk of intergranular corrosion. The alloy is used in severe corrosion conditions such as in the petrochemical, pulp and paper industries.

Specifications

Classifications	EN ISO 14343-A : W18 15 3 L SFA/AWS A5.9 : ER317L
------------------------	--

Alloy Type	Austenitic (with approx. 8 % ferrite) 19% Cr - 12% Ni - 3% Mo - Low C
Shielding Gas	I1 (EN ISO 14175)

Typical Tensile Properties

Condition	Yield Strength	Tensile Strength	Elongation
As Welded	390 MPa	600 MPa	42 %

Typical Charpy V-Notch Properties

Condition	Testing Temperature	Impact Value
As Welded	20 °C	135 J
As Welded	-196 °C	55 J

Typical Wire Composition %

C	Mn	Si	S	P	Ni	Cr	Mo	Cu	N
0.01	1.4	0.4	0.009	0.02	13.7	19	3.6	0.11	0.05

Typical Wire Composition %

FN WRC-92
8

OK Tigrod 318Si

Bare corrosion resisting stabilized chromium-nickel-molybdenum wire for welding of Cr-Ni-Mo and Cr-Ni stabilized or non-stabilized steels. OK Tigrod 318Si has a good general corrosion resistance. The alloy is stabilized with niobium to improve the resistance against intergranular corrosion of the weld metal. The higher silicon content improves the welding properties, such as wetting. Due to stabilization of niobium this alloy is recommended for service temperatures up to 400°C.

Specifications	
Classifications	EN ISO 14343-A : W 19 12 3 Nb Si SFA/AWS A5.9 : ER318 (mod) Werkstoffnummer : ~1.4576
Approvals	CE : EN 13479 DB : 43.039.15 UKCA : EN 13479 VdTÜV : 09737

Approvals are based on factory location. Please contact ESAB for more information.

Alloy Type	Austenitic (with approx. 7 % ferrite) 19% Cr - 12% Ni - 3 % Mo - Nb
Shielding Gas	I1 (EN ISO 14175)

Typical Tensile Properties			
Condition	Yield Strength	Tensile Strength	Elongation
As Welded	460 MPa	615 MPa	35 %

Typical Charpy V-Notch Properties		
Condition	Testing Temperature	Impact Value
As Welded	20 °C	40 J
As Welded	-60 °C	70 J

Typical Weld Metal Analysis %									
C	Mn	Si	S	P	Ni	Cr	Mo	Cu	N
0.04	1.3	0.8	0.01	0.02	12	19	2.8	0.1	0.05

Typical Weld Metal Analysis %	
Nb	FN WRC-92
0.5	12

Typical Wire Composition %							
C	Mn	Si	Ni	Cr	Mo	Cu	Nb
0.05	1.7	0.8	11.9	18.8	2.60	0.10	0.50

OK Tigrod 347

Bare corrosion resisting chromium-nickel rods for welding of stabilized austenitic chromium nickel alloys of 18% Cr - 8% Ni-type. The rods are stabilized with Niobium, which gives a good resistance to intergranular corrosion of the weld metal. Due to the niobium content this alloy is recommended for use at higher temperatures.

Specifications	
Classifications	EN ISO 14343-A : W 19 9 Nb SFA/AWS A5.9 : ER347 Werkstoffnummer : ~1.4550
Approvals	CE : EN 13479 UKCA : EN 13479 VdTÜV : 19918

Approvals are based on factory location. Please contact ESAB for more information.

Alloy Type	Austenitic (with approx. 8 % ferrite) 19% Cr - 9% Ni - Nb
Shielding Gas	I1 (EN ISO 14175)

Typical Tensile Properties			
Condition	Yield Strength	Tensile Strength	Elongation
As Welded	510 MPa	655 MPa	35 %

Typical Charpy V-Notch Properties		
Condition	Testing Temperature	Impact Value
As Welded	20 °C	130 J

Typical Weld Metal Analysis %									
C	Mn	Si	S	P	Ni	Cr	Mo	V	Al
0.04	1.3	0.4	0.009	0.016	9.2	18.8	0.1	0.05	0.002

Typical Weld Metal Analysis %					
Cu	N	Nb	Ti	Co	FN WRC-92
0.1	0.06	0.6	0.003	0.1	8

Typical Wire Composition %							
C	Mn	Si	Ni	Cr	Mo	Cu	Nb
0.04	1.4	0.4	9.5	19.3	0.10	0.05	0.50

OK Tigrod 347Si

Bare corrosion resisting chromium-nickel rods for welding of austenitic chromium nickel alloys of 18 % Cr-8 % Ni-type. OK Tigrod 347Si has a good general corrosion resistance. The alloy is stabilized with Niobium to improve the resistance against intergranular corrosion of the weld metal. The higher silicon content improves the welding properties, such as wetting. Due to the niobium content this alloy is recommended for use at higher temperatures.

Specifications	
Classifications	EN ISO 14343-A : W 19 9 Nb Si SFA/AWS A5.9 : ER347Si Werkstoffnummer : ~1.4550
Approvals	CE : EN 13479 UKCA : EN 13479 VdTÜV : 09736

Approvals are based on factory location. Please contact ESAB for more information.

Alloy Type	Austenitic (with approx. 8 % ferrite) 19% Cr - 9% Ni - Nb
Shielding Gas	I1 (EN ISO 14175)

Typical Tensile Properties			
Condition	Yield Strength	Tensile Strength	Elongation
As Welded	440 MPa	640 MPa	35 %

Typical Charpy V-Notch Properties		
Condition	Testing Temperature	Impact Value
As Welded	20 °C	90 J
As Welded	-60 °C	75 J

Typical Weld Metal Analysis %									
C	Mn	Si	S	P	Ni	Cr	Mo	Cu	N
0.04	1.5	0.8	0.01	0.02	10	20	0.1	0.1	0.05

Typical Weld Metal Analysis %	
Nb	FN WRC-92
0.7	8

Typical Wire Composition %							
C	Mn	Si	Ni	Cr	Mo	Cu	Nb
0.04	1.7	0.7	9.8	19	0.1	0.10	0.60

OK Tigrod 410NiMo

Bare welding rods of "410NiMo" type alloyed with 13 % Cr, 4.5 % Ni and 0.5 % Mo. This alloy is used for welding of similar martensitic and martensitic-feritic steels in different applications such as for example hydro-turbines.

Specifications

Classifications	EN ISO 14343-A : W 13 4
------------------------	-------------------------

Alloy Type	Martensitic-ferritic (13 % Cr - 4.5 % Ni - 0.5 % Mo)
Shielding Gas	I1 (EN ISO 14175)

Typical Tensile Properties

Condition	Yield Strength	Tensile Strength	Elongation
Stress Relieved 2 hour(s) 600 °C	930 MPa	1000 MPa	17 %
Stress Relieved 8 hour(s) 600 °C	770 MPa	870 MPa	22 %

Typical Charpy V-Notch Properties

Condition	Testing Temperature	Impact Value
Stress Relieved 2 hour(s) 600 °C	0 °C	120 J
Stress Relieved 8 hour(s) 600 °C	0 °C	175 J
Stress Relieved 2 hour(s) 600 °C	-20 °C	120 J
Stress Relieved 8 hour(s) 600 °C	-20 °C	165 J

Typical Weld Metal Analysis %

C	Mn	Si	S	P	Ni	Cr	Mo
0.02	0.4	0.4	0.01	0.02	4.5	12	0.4

Typical Wire Composition %

C	Mn	Si	S	P	Ni	Cr	Mo	Cu
0.02	0.43	0.37	0.004	0.017	4.5	12.2	0.4	0.07

OK Tigrod 430LNbTi

A ferritic stainless solid wire with low carbon content and excellent welding properties, 18 % Cr and stabilized with Nb and Ti, for welding similar and matching steels. OK Tigrod 430LNbTi is developed and designed for the Automotive industry and used for production of exhaust systems. The wire should be used when there is a need for very good resistance to corrosion and thermal fatigue.

Specifications

Classifications	EN ISO 14343-A : W 18 L Nb Ti Werkstoffnummer : ~1.4509
Approvals	CE : EN 13479 UKCA : EN 13479

Approvals are based on factory location. Please contact ESAB for more information.

Alloy Type	18 % Cr – Nb and Ti stabilized
Shielding Gas	11 (EN ISO 14175)

Typical Wire Composition %

C	Mn	Si	S	P	Ni	Cr	Mo	Cu	N
0.01	0.5	0.5	0.005	0.020	0.2	18.5	0.06	0.10	0.017

Typical Wire Composition %

Nb	Ti
0.5	0.30

Exaton 19.9.L (GMAW)

Exaton 19.9.L is suitable for joining stainless steels of the 18Cr/8Ni/ELC and 18Cr/8Ni/Nb types for service temperatures up to 350°C (662°F). It is also suitable for welding equipment intended to be used in cryogenic applications down to 4°K (-269°C) Typical cryogenic applications: manufacturing of dewars, containers, tanks, cryostats, and transfer systems for transportation and storage of LNG, LPG, liquid nitrogen and liquid helium. The chemical composition is optimized for cryogenic applications in terms of impact strength, lateral expansion and other characteristics. The controlled chemical composition and ferrite content are optimized for resistance to microfissuring, and balanced minor additions of certain elements for optimum arc stability, fluidity and low spatter. It is used for joining and overlay welding with MIG/MAG, plasma and hot wire TIG and mechanized TIG.

Specifications	
Classifications	EN ISO 14343-A : G/W/P 19 9 L SFA/AWS A5.9 : ER308L Werkstoffnummer : ~ 1.4316
Approvals	CE : EN 13479 UKCA : EN 13479 VdTÜV : 00064(GTAW) VdTÜV : 01339

Approvals are based on factory location. Please contact ESAB for more information.

Alloy Type	Austenitic (with approx. 8 % ferrite) 19% Cr - 9% Ni - Low C
Shielding Gas	M12, M13 (EN ISO 14175)

Typical Tensile Properties			
Condition	Yield Strength	Tensile Strength	Elongation
As Welded	420 MPa	570 MPa	41 %
As Welded 50 °C	310 MPa	410 MPa	29 %
As Welded 00 °C	290 MPa	440 MPa	25 %

Typical Charpy V-Notch Properties		
Condition	Testing Temperature	Impact Value
As Welded	20 °C	150 J
As Welded	-196 °C	90 J
As Welded	-196 °C	80 J
As Welded	-269 °C	40 J

Typical Weld Metal Analysis %									
C	Mn	Si	S	P	Ni	Cr	Mo	Cu	N
Shielding Gas - M13									
0.021	1.6	0.3	0.010	0.021	10.5	19.5	0.2	0.16	0.08

Typical Weld Metal Analysis %				
Nb	Ti	Co	FN deLong	FN WRC-92
Shielding Gas - M13				
0.01	0.003	0.08	4	5

Typical Wire Composition %									
C	Mn	Si	S	P	Ni	Cr	Mo	Cu	N
0.019	1.7	0.4	0.012	0.022	10.6	19.8	0.2	0.2	0.06

Typical Wire Composition %				
Nb	Ti	Co	FN deLong	FN WRC-92

Exaton 19.9.L (GMAW)

Typical Wire Composition %

Nb	Ti	Co	FN deLong	FN WRC-92
0.02	0.004	0.07	6	7

Recommended Welding Parameters

Wire Diameter	Current	Voltage	Wire Feed Speed
0.8 mm	40-120 A	15-19 V	4.0-8.0 mm/min
1.0 mm	60-220 A	15-28 V	4.0-12.0 mm/min
1.2 mm	150-260 A	24-29 V	3.0-10.0 mm/min
1.6 mm	230-350 A	25-30 V	3.0-5.0 mm/min

Exaton 19.9.LSi (GMAW)

Exaton 19.9.LSi is a filler metal particularly suited for MIG/MAG welding but can also be used for plasma and hot wire TIG and mechanized TIG welding. It is suitable for joining stainless steels of the 18Cr/8Ni ELC-type and 18Cr/8Ni/Nb type for service temperatures up to 350°C (660°F).

Specifications	
Classifications	EN ISO 14343-A : GW/P 19 9 L Si SFA/AWS A5.9 : ER308LSi Werkstoffnummer : ~ 1.4316
Approvals	CE : EN 13479 DB : 43.118.01 UKCA : EN 13479 VdTÜV : 00065 VdTÜV : 00869(GTAW)

Approvals are based on factory location. Please contact ESAB for more information.

Alloy Type	Austenitic (with approx. 8 % ferrite) 19% Cr - 9% Ni - Low C - High Si
Shielding Gas	M11, M12 (EN ISO 14175)

Typical Tensile Properties			
Condition	Yield Strength	Tensile Strength	Elongation
As Welded	390 MPa	600 MPa	42 %
As Welded 400 °C	290 MPa	440 MPa	24 %

Typical Charpy V-Notch Properties		
Condition	Testing Temperature	Impact Value
As Welded	20 °C	135 J
As Welded	-196 °C	50 J

Typical Weld Metal Analysis %									
C	Mn	Si	S	P	Ni	Cr	Mo	Cu	N
0.02	1.7	0.7	0.010	0.020	10.3	19.6	0.02	0.13	0.06

Typical Weld Metal Analysis %	
Nb	FN WRC-92
0.01	8

Typical Wire Composition %									
C	Mn	Si	S	P	Ni	Cr	Mo	Cu	N
0.013	1.8	0.9	0.011	0.021	10	20	0.2	0.2	0.06
-	-	0.9	-	-	-	-	-	-	-

Typical Wire Composition %			
Nb	Ti	Co	FN WRC-92

Deposition Data				
Diameter	Current	Voltage	Wire Feed Speed	Deposition Rate
0.9 mm	65-220 A	15-28 V	3.5-18.0 m/min	1.1-5.4 kg/h

Exaton 19.9.LSi (GMAW)

Recommended Welding Parameters			
Wire Diameter	Current	Voltage	Wire Feed Speed
0.8 mm	40-120 A	15-19 V	4.0-8.0 mm/min
1.0 mm	60-220 A	15-28 V	4.0-12.0 mm/min
1.2 mm	150-260 A	24-29 V	3.0-10.0 mm/min
1.6 mm	230-350 A	25-30 V	3.0-5.0 mm/min

Exaton 19.12.3.L CRYO (GMAW)

Exaton 19.12.3.L CRYO is a filler material for joining austenitic stainless steels, e.g. ASTM 316, 316L, as well as 304, 304L, for cryogenic applications and meets the requirements of ASME Section VIII, Division 1, UHA 51 ((a) (4) (-a) (-1)) and others. It is used for service temperatures down to -269°C (-452°F), and ferritic or martensitic stainless steels, with maximum 19% Cr. The grade has been specifically developed for welding in cryogenic applications, typically: manufacturing of dewars, containers, tanks, cryostats, and transfer systems for transportation and storage of LNG, LPG, liquid nitrogen and liquid helium. It can be used for plasma welding and overlay welding using hot wire TIG and mechanical TIG. The chemical composition is optimized for cryogenic applications in terms of impact strength and other characteristics. It has controlled chemical composition and ferrite content for resistance to microfissuring, and balanced minor additions of certain elements for optimum arc stability and wetting characteristics. Impurity levels are lower in the consumable in order to reduce the risk of hot cracking and to obtain the best arc stability, fluidity, low spatter and wetting properties.

Specifications	
Classifications	EN ISO 14343-A : G/W/P (19 12 3 L) SFA/AWS A5.9 : ER316L Werkstoffnummer : ~1.4430 EN ISO 14343-B : SS316L
Approvals	CE : EN 13479 UKCA : EN 13479

Approvals are based on factory location. Please contact ESAB for more information.

Alloy Type	Austenitic (with appr. 2 % ferrite) 19 % Cr - 13 % Ni - 2 % Mo - Low C
Shielding Gas	I1, M12, M13 (EN ISO 14175)

Typical Tensile Properties			
Condition	Yield Strength	Tensile Strength	Elongation
As welded ISO			
As Welded	400 MPa	560 MPa	35 %

Typical Charpy V-Notch Properties		
Condition	Testing Temperature	Impact Value
As welded ISO		
As Welded	-196 °C	50 J

Typical Weld Metal Analysis %									
C	Mn	Si	S	P	Ni	Cr	Mo	Al	Cu
0.02	1.8	0.4	0.002	0.014	12.9	18.4	2.3	0.01	0.05

Typical Weld Metal Analysis %				
N	Nb	Ti	Co	FN WRC-92
0.06	0.01	0.002	0.03	3

Typical Wire Composition %									
C	Mn	Si	S	P	Ni	Cr	Mo	Al	Cu
0.02	1.8	0.4	0.003	0.012	13.3	18.5	2.3	0.01	0.06

Typical Wire Composition %				
N	Nb	Ti	Co	FN WRC-92
0.06	0.01	0.005	0.03	2

Recommended Welding Parameters			
Wire Diameter	Current	Voltage	Wire Feed Speed
1.0 mm	60-220 A	15-28 V	4.0-12.0 mm/min

Exaton 19.12.3.L CRYO (GMAW)

Recommended Welding Parameters

Wire Diameter	Current	Voltage	Wire Feed Speed
1.2 mm	150-260 A	24-29 V	3.0-10.0 mm/min

Exaton 19.12.3.LSiMo (GMAW)

Exaton 19.12.3.LSiMo is used for welding of austenitic stainless alloys of 18% Cr - 8% Ni and 18% Cr - 10% Ni - 3% Mo-types, stabilized or non-stabilized, e.g. ASTM 316, 316L and 316Ti as well as 304, 304L, 321 and 347, for service temperatures up to 400°C (750°F). It is also used for welding of stainless Cr-steels with max 19% Cr. The alloy has increased corrosion resistance compared to standard 316LSi due to its guaranteed high Mo content of around 2.9%. The critical pitting temperature, CPT, according to ASTM G150 (1°C of accuracy) can be as high as 39°C compared to standard 316LSi, which achieved maximum 29°C during the benchmark. It is used for joining and overlay welding with MIG/MAG, plasma and hot wire TIG and mechanized TIG.

Specifications	
Classifications	EN ISO 14343-A : G/W/P 19 12 3 L Si SFA/AWS A5.9 : 316LSi Werkstoffnummer : ~1.4430
Approvals	CE : EN 13479 UKCA : EN 13479

Approvals are based on factory location. Please contact ESAB for more information.

Alloy Type	Austenitic (with appr. 9 % ferrite) 19 % Cr - 12 % Ni - 3 % Mo - Low C - High Si
Shielding Gas	M12, M13 (EN ISO 14175)

Typical Tensile Properties			
Condition	Yield Strength	Tensile Strength	Elongation
As Welded	455 MPa	600 MPa	35 %

Typical Charpy V-Notch Properties		
Condition	Testing Temperature	Impact Value
As Welded	20 °C	95 J
As Welded	-110 °C	60 J
As Welded	-196 °C	35 J

Typical Weld Metal Analysis %										
C	Mn	Si	S	P	Ni	Cr	Mo	Cu	N	
0.02	1.7	1.0	0.007	0.017	12	18.5	2.8	0.1	0.06	

Typical Weld Metal Analysis %		
Nb	Co	FN WRC-92
0.02	0.05	7

Typical Wire Composition %										
C	Mn	Si	S	P	Ni	Cr	Mo	Cu	N	
0.013	1.8	0.9	0.010	0.018	12	18.5	2.9	0.10	0.05	

Typical Wire Composition %			
Nb	Ti	Co	FN WRC-92
0.04	0.002	0.05	9

Deposition Data				
Diameter	Current	Voltage	Wire Feed Speed	Deposition Rate
0.8 mm	55-160 A	12-24 V	4.0-17.0 m/min	1.0-4.1 kg/h
1.0 mm	80-240 A	15-28 V	4.0-16.0 m/min	1.5-6.0 kg/h
1.2 mm	100-300 A	15-29 V	3.0-14.0 m/min	1.6-7.5 kg/h

Exaton 19.13.4.L (GMAW)

Exaton 19.13.4.L is suitable for joining stainless CrNiMo steels e.g. 317L or similar. It's corrosion resistance is better than 316L and used in corrosive environments where crevice and pitting corrosion are of concern.

Specifications

Classifications	EN ISO 14343-A : G/W/P 19 13 4 L SFA/AWS A5.9 : ER317L Werkstoffnummer : 1.4438*
------------------------	--

Alloy Type	Austenitic 19 % Cr - 13.5 % Ni - 3.5 % Mo - Low C
Shielding Gas	M12, M13 (EN ISO 14175)

Typical Tensile Properties

Condition	Yield Strength	Tensile Strength	Elongation
As Welded	380 MPa	600 MPa	42 %

Typical Charpy V-Notch Properties

Condition	Testing Temperature	Impact Value
As Welded	20 °C	140 J

Typical Wire Composition %

C	Mn	Si	S	P	Ni	Cr	Mo	Cu	N
0.01	1.4	0.4	0.01	0.02	13.7	18.9	3.6	0.11	0.04

Typical Wire Composition %

FN WRC-92
8

Exaton 20.25.5.LCu (GMAW)

Exaton 20.25.5.LCu welding wire is suitable for joining stainless steels, such as UNS N08904 (e.g. Alleima® 2RK65™) used in many areas of the process industry like production of acetic acid, sulfuric acid, terephthalic or tartaric acid and vinyl chloride. It is also suitable for use in cooling operations involving sea water or heavily polluted river water. It can be used for plasma welding and overlay welding using hot wire TIG and mechanized TIG.

Specifications	
Classifications	EN ISO 14343-A : G/W/P 20 25 5 Cu L SFA/AWS A5.9 : ER385 Werkstoffnummer : ~1.4519
Approvals	CE : EN 13479 UKCA : EN 13479 VdTÜV : 02223(GTAW) VdTÜV : 03941

Approvals are based on factory location. Please contact ESAB for more information.

Alloy Type	Austenitic, 20% Cr, 25% Ni, 4.5% Mo, 1.5% Cu, low C
Shielding Gas	M12, M13 (EN ISO 14175)

Typical Tensile Properties			
Condition	Yield Strength	Tensile Strength	Elongation
As Welded 0 °C	370 MPa	580 MPa	34 %
As Welded+ 00 °C	275 MPa	440 MPa	32 %

Typical Charpy V-Notch Properties		
Condition	Testing Temperature	Impact Value
As Welded	20 °C	120 J
As Welded	-110 °C	80 J
As Welded	-196 °C	70 J

Typical Weld Metal Analysis %									
C	Mn	Si	S	P	Ni	Cr	Mo	Al	Cu
0.02	1.8	0.3	0.001	0.014	24.8	19.8	4.3	0.01	1.4

Typical Weld Metal Analysis %		
N	Nb	Co
0.06	0.01	0.1

Typical Wire Composition %									
C	Mn	Si	S	P	Ni	Cr	Mo	Al	Cu
0.01	1.8	0.3	0.002	0.013	25	20	4.3	0.02	1.5

Typical Wire Composition %			
N	Nb	Ti	Co
0.05	0.01	0.003	0.1

Recommended Welding Parameters			
Wire Diameter	Current	Voltage	Wire Feed Speed
1.0 mm	60-220 A	15-28 V	4.0-12.0 mm/min
1.2 mm	150-260 A	24-29 V	3.0-10.0 mm/min

Exaton 20.25.5.LCu (GMAW)

Recommended Welding Parameters

Wire Diameter	Current	Voltage	Wire Feed Speed
1.6 mm	230-350 A	25-30 V	3.0-5.0 mm/min

Exaton 22.8.3.L (GMAW)

Exaton 22.8.3.L is designed for gas shielded arc welding of duplex stainless steels, such as UNS S32304 (e.g. SAF™ 2304) and UNS S31803 / S32205 (e.g. SAF™ 2205). Its corrosion resistance is equal to UNS N08904 (e.g. Alleima® 2RK65™) in most applications. It combines high strength with excellent ductility. Exaton 22.8.3.L can also be used for joining UNS S32304 and UNS S31803 / S32205 to carbon steel or low-alloy steels. It is used for joining and overlay welding with MIG/MAG, plasma and hot wire TIG and mechanized TIG.

Specifications	
Classifications	EN ISO 14343-A : GW/P 22 9 3 N L SFA/AWS A5.9 : ER2209 EN ISO 14343-B : 2209
Approvals	CE : EN 13479 DNV-GL : Stainless steel* UKCA : EN 13479 VdTÜV : 19479

Approvals are based on factory location. Please contact ESAB for more information.

Alloy Type	Austenitic-ferritic (duplex) with approx. 55 FN ferrite - 22.5% Cr - 8% Ni - 3% Mo - Low C
Shielding Gas	M12, M13 (EN ISO 14175)

Typical Tensile Properties			
Condition	Yield Strength	Tensile Strength	Elongation
As Welded	550 MPa	770 MPa	30 %

Typical Charpy V-Notch Properties		
Condition	Testing Temperature	Impact Value
As Welded	20 °C	110 J
As Welded	-20 °C	105 J
As Welded	-40 °C	100 J
As Welded	-46 °C	95 J
As Welded	-50 °C	90 J

Typical Weld Metal Analysis %										
C	Mn	Si	S	P	Ni	Cr	Mo	Cu	N	
0.014	1.5	0.45	0.001	0.017	8.5	23	3.0	0.09	0.15	

Typical Weld Metal Analysis %			
Nb	PRE	FN WRC-92	W
0.01	35.3	52	0.01

Typical Wire Composition %										
C	Mn	Si	S	P	Ni	Cr	Mo	V	Cu	
0.012	1.5	0.5	0.0007	0.018	8.6	23	3.2	0.05	0.09	

Typical Wire Composition %							
N	Nb	Ti	Co	PRE	FN WRC-92	W	
0.15	0.01	0.003	0.04	37	55	0.01	

Exaton 22.8.3.L (GMAW)

Recommended Welding Parameters			
Wire Diameter	Current	Voltage	Wire Feed Speed
0.8 mm	40-120 A	15-19 V	4.0-8.0 mm/min
1.0 mm	60-220 A	15-28 V	4.0-12.0 mm/min
1.2 mm	150-260 A	24-29 V	3.0-10.0 mm/min
1.6 mm	230-350 A	25-30 V	3.0-5.0 mm/min

Exaton 22.8.3.LSi (GMAW)

Exaton 22.8.3.LSi is designed for gas shielded arc welding of duplex stainless steels, such as UNS S32304 (e.g. SAF™ 2304) and UNS S31803 / S32205 (e.g. SAF™ 2205). Its corrosion resistance is equal to UNS N08904 (e.g. Alleima® 2RK65™) in most applications. It combines high strength with excellent ductility. Exaton 22.8.3.LSi can also be used for joining UNS S32304 and UNS S31803 / S32205 to carbon steel or low-alloy steels. It can be used for plasma welding and overlay welding using hot wire TIG and mechanical TIG.

Specifications	
Classifications	EN ISO 14343-A : GW/P 22 9 3 N L SFA/AWS A5.9 : ER2209 EN ISO 14343-B : 2209
Approvals	CE : EN 13479 DB : 0.6-1.6mm UKCA : EN 13479 VdTÜV : 0.6-1.6mm VdTÜV : 10055(GTAW)

Approvals are based on factory location. Please contact ESAB for more information.

Alloy Type	Austenitic-ferritic (duplex) with approx. 55 FN ferrite - 22.5% Cr - 8% Ni - 3% Mo - Low C + Si
Shielding Gas	M12, M13 (EN ISO 14175)

Typical Tensile Properties			
Condition	Yield Strength	Tensile Strength	Elongation
AWS			
As Welded	630 MPa	810 MPa	32 %
ISO			
As Welded	660 MPa	830 MPa	30 %

Typical Charpy V-Notch Properties		
Condition	Testing Temperature	Impact Value
AWS		
As Welded	20 °C	150 J
As Welded	-30 °C	145 J
As Welded	-46 °C	140 J
As Welded	-60 °C	95 J
ISO		
As Welded	20 °C	120 J
As Welded	-40 °C	90 J
As Welded	-60 °C	85 J

Typical Weld Metal Analysis %									
C	Mn	Si	S	P	Ni	Cr	Mo	Cu	N
0.02	1.5	0.7	0.001	0.02	8.6	23	3.1	0.1	0.16*

Typical Weld Metal Analysis %					
Nb	Ti	Co	PRE	FN WRC-92	W
0.01	0.002	0.07	35.8	54	0.01

Typical Wire Composition %									
C	Mn	Si	S	P	Ni	Cr	Mo	V	Cu

Exaton 22.8.3.LSi (GMAW)

Typical Wire Composition %

C	Mn	Si	S	P	Ni	Cr	Mo	V	Cu
0.012	1.5	0.8	0.0007	0.018	8.6	23	3.2	0.05	0.09

Typical Wire Composition %

N	Nb	Ti	Co	PRE	FN WRC-92	W
0.15	0.01	0.003	0.04	37	55	0.01

Recommended Welding Parameters

Wire Diameter	Current	Voltage	Wire Feed Speed
0.8 mm	40-120 A	15-19 V	4.0-8.0 mm/min
1.0 mm	60-220 A	15-28 V	4.0-12.0 mm/min
1.2 mm	150-260 A	24-29 V	3.0-10.0 mm/min

Exaton 22.12.HT (GMAW)

Exaton 22.12.HT is an austenitic stainless steel filler material for welding high temperature steel grades, such as UNS 30815, EN 1.4835 (e.g. Alleima® 253 MA). It is characterized by high creep strength, good resistance to oxidation and good weldability. Exaton 22.12.HT is used for MIG/MAG welding, plasma welding and overlay welding using hot wire TIG and mechanical TIG.

Specifications	
Classifications	EN ISO 14343-A : GW/P 21 10 N EN 10088-1 : 1.4835
Approvals	CE : EN 13479 UKCA : EN 13479

Approvals are based on factory location. Please contact ESAB for more information.

Alloy Type	Austenitic (with appr. 9 % ferrite) - 21% Cr - 10% Ni - Low C
Shielding Gas	I1, I3, M12 (EN ISO 14175)

Typical Tensile Properties			
Condition	Yield Strength	Tensile Strength	Elongation
As Welded	530 MPa	720 MPa	35 %

Typical Charpy V-Notch Properties		
Condition	Testing Temperature	Impact Value
As Welded	20 °C	125 J
As Welded	-110 °C	40 J
As Welded	-196 °C	15 J

Typical Weld Metal Analysis %									
C	Mn	Si	S	P	Ni	Cr	Mo	Al	Cu
0.08	0.6	1.6	0.0009	0.024	9.9	20.7	0.08	0.003	0.06

Typical Weld Metal Analysis %						
N	Nb	Ti	Co	B	FN deLong	Ce
0.17	0.005	0.002	0.04	0.0002	6	0.04

Typical Wire Composition %									
C	Mn	Si	S	P	Ni	Cr	Mo	Al	Cu
0.07	0.5	1.6	0.0007	0.020	10.2	21.0	0.1	0.01	0.1

Typical Wire Composition %						
N	Nb	Ti	Co	B	FN deLong	Ce
0.17	0.01	0.005	0.05	0.0008	9	0.04

Recommended Welding Parameters			
Wire Diameter	Current	Voltage	Wire Feed Speed
1.0 mm	60-220 A	15-28 V	4.0-12.0 mm/min
1.2 mm	150-260 A	24-29 V	3.0-10.0 mm/min

Exaton 24.13.LHF (GMAW)

Exaton 24.13.LHF welding wire is used for MIG/MAG welding. It is used for joining dissimilar steels, for example austenitic stainless steels to low alloyed or non alloyed steels. It has excellent resistance to hot cracking due to its enhanced ferrite content. Exaton 24.13.LHF can also be used for plasma welding and overlay welding using hot wire TIG and mechanized TIG.

Specifications	
Classifications	EN ISO 14343-A : G/W/P 23 12 L SFA/AWS A5.9 : ER309L
Approvals	CE : EN 13479 UKCA : EN 13479 VdTÜV : 00936(GTAW) VdTÜV : 02103

Approvals are based on factory location. Please contact ESAB for more information.

Alloy Type	Austenitic (with approx. 14 % ferrite) 24 % Cr - 13 % Ni - Low C
Shielding Gas	M12, M13 (EN ISO 14175)

Typical Tensile Properties			
Condition	Yield Strength	Tensile Strength	Elongation
As Welded	450 MPa	610 MPa	30 %

Typical Charpy V-Notch Properties		
Condition	Testing Temperature	Impact Value
As Welded	20 °C	110 J
As Welded	-60 °C	85 J
As Welded	-196 °C	35 J

Typical Weld Metal Analysis %									
C	Mn	Si	S	P	Ni	Cr	Mo	V	Cu
0.02	1.7	0.3	0.001	0.013	13.4	23.6	0.02	0.03	0.01

Typical Weld Metal Analysis %				
N	Nb	Co	FN deLong	FN WRC-92
0.07	0.01	0.03	12	11

Typical Wire Composition %									
C	Mn	Si	S	P	Ni	Cr	Mo	V	Cu
0.01	1.8	0.4	0.001	0.011	13.4	23.5	0.04	0.05	0.03

Typical Wire Composition %					
N	Nb	Ti	Co	FN deLong	FN WRC-92
0.05	0.03	0.004	0.03	14	13

Recommended Welding Parameters				
Wire Diameter	Current	Voltage	Wire Feed Speed	
1.2 mm	150-260 A	24-29 V	3.0-10.0 mm/min	

Exaton 24.13.LNb (GMAW)

Exaton 24.13.LNb is a niobium-stabilized overalloyed filler metal suitable for overlay welding of carbon and low alloy steels, where a type 347 of overlay is required in one layer. Typical applications is cladding of shells and inlets of hydrocrackers, which has a service temperature of 600-650°C. It is used for MIG/MAG welding as well as for plasma welding and overlay welding using hot wire TIG and mechanized TIG.

Specifications

Classifications	EN ISO 14343-A : G/W/P 23 12 Nb SFA/AWS A5.9 : ER309LNb
Approvals	CE : EN 13479 UKCA : EN 13479

Approvals are based on factory location. Please contact ESAB for more information.

Alloy Type	Austenitic (with approx. 15 % ferrite) 24 % Cr - 13 % Ni - Low C - Nb
Shielding Gas	M12, M13 (EN ISO 14175)

Typical Tensile Properties

Condition	Yield Strength	Tensile Strength	Elongation
EN ISO			
As Welded	500 MPa	670 MPa	29 %

Typical Charpy V-Notch Properties

Condition	Testing Temperature	Impact Value
EN ISO		
As Welded	20 °C	130 J
As Welded	-60 °C	100 J
As Welded	-196 °C	15 J

Typical Weld Metal Analysis %

C	Mn	Si	S	P	Ni	Cr	Mo	Cu	N
0.02	2.2	0.2	0.001	0.012	12.5	23.2	0.01	0.01	0.07

Typical Weld Metal Analysis %

Nb	Co	FN deLong
0.8	0.02	13

Typical Wire Composition %

C	Mn	Si	S	P	Ni	Cr	Mo	Cu	N
0.01	2.1	0.3	0.001	0.013	12.5	24	0.02	0.01	0.05

Typical Wire Composition %

Nb	Ti	Co
0.8	0.005	0.02

Recommended Welding Parameters

Wire Diameter	Current	Voltage	Wire Feed Speed
1.2 mm	150-260 A	24-29 V	3.0-10.0 mm/min

Exaton 25.10.4.L (GMAW)

Exaton 25.10.4.L is designed for gas shielded arc welding of superduplex stainless steels, such as UNS S32750 (e.g. SAF™ 2507), UNS S32760 and UNS S31803 / S32205 (e.g. SAF™ 2205). It combines high strength with excellent ductility. Exaton 25.10.4.L can also be used for joining UNS S32750 and S32760 to carbon steel or low-alloy steels. It is used for joining and overlay welding with MIG/MAG, plasma and hot wire TIG and mechanical TIG. Exaton 25.10.4.L can also be used for welding duplex stainless steels when the highest possible corrosion resistance is required. The grade is characterized by excellent resistance to stress corrosion cracking in chloride-bearing environments and excellent resistance to pitting and crevice corrosion. Its corrosion resistance is equal to UNS S31254 (e.g. Alleima® 254SMO™) in most applications.

Specifications	
Classifications	EN ISO 14343-A : G/W/P 25 9 4 N L SFA/AWS A5.9 : ER2594
Approvals	ABS : ER 2594 CE : EN 13479 DNV-GL : Duplex steels UKCA : EN 13479

Approvals are based on factory location. Please contact ESAB for more information.

Alloy Type	Austenitic-ferritic (duplex) with approx. 50 FN ferrite - 25% Cr - 10% Ni - 4% Mo - Low C
Shielding Gas	M12 (EN ISO 14175)

Typical Tensile Properties			
Condition	Yield Strength	Tensile Strength	Elongation
As Welded	700 MPa	880 MPa	30 %

Typical Charpy V-Notch Properties		
Condition	Testing Temperature	Impact Value
As Welded	20 °C	230 J
As Welded	-50 °C	170 J

Typical Weld Metal Analysis %									
C	Mn	Si	S	P	Ni	Cr	Mo	V	Cu
0.01	0.3	0.4	0.001	0.02	9.4	25	4.0	0.06	0.1

Typical Weld Metal Analysis %					
N	Nb	Co	PRE	FN WRC-92	W
0.25	0.01	0.04	41.7	52	0.01

Typical Wire Composition %									
C	Mn	Si	S	P	Ni	Cr	Mo	V	Cu
0.012	0.4	0.3	0.0005	0.015	9.5	25	4	0.05	0.07

Typical Wire Composition %							
N	Nb	Ti	Co	PRE	FN WRC-92	W	
0.25	0.01	0.003	0.04	42	50	0.01	

Recommended Welding Parameters			
Wire Diameter	Current	Voltage	Wire Feed Speed
0.8 mm	40-120 A	15-19 V	4.0-8.0 mm/min
1.0 mm	60-220 A	15-28 V	4.0-12.0 mm/min
1.2 mm	150-260 A	24-29 V	3.0-10.0 mm/min

Exaton 25.10.4.L (GMAW)

Recommended Welding Parameters

Wire Diameter	Current	Voltage	Wire Feed Speed
1.6 mm	230-350 A	25-30 V	3.0-5.0 mm/min

Exaton 25.20.L (GMAW)

Exaton 25.20.L is an austenitic stainless steel filler material for joining steel grades, such as UNS 31002, EN 1.4335 (e.g. Alleima® 2RE10) and similar grades used in heavily oxidizing media, such as nitric acid production, where pipes in preheaters, coolers and condensers are used in the chemical industry. It is used for joining and overlay welding with MIG/MAG, plasma and hot wire TIG and mechanized TIG.

Specifications	
Classifications	EN ISO 14343-A : G/W/P Z 25 20 L SFA/AWS A5.9 : ER310 (mod) EN 10088-1 : 1.4335
Approvals	CE : EN 13479 UKCA : EN 13479

Approvals are based on factory location. Please contact ESAB for more information.

Alloy Type	Austenitic - 24.5% Cr - 20.5% Ni - Low C
Shielding Gas	I1, M12, M13 (EN ISO 14175)

Typical Tensile Properties		
Condition	Yield Strength	Tensile Strength
As Welded	350 MPa	510 MPa

Typical Charpy V-Notch Properties		
Condition	Testing Temperature	Impact Value
As Welded	20 °C	135 J
As Welded	-196 °C	100 J

Typical Weld Metal Analysis %									
C	Mn	Si	S	P	Ni	Cr	Mo	Cu	N
0.02	1.6	0.05	0.001	0.017	20.2	24.2	0.07	0.01	0.03

Typical Weld Metal Analysis %	
Nb	Co
0.01	0.04

Typical Wire Composition %									
C	Mn	Si	S	P	Ni	Cr	Mo	Cu	N
0.01	1.8	0.1	0.0005	0.014	20.4	24.5	0.1	0.01	0.05

Typical Wire Composition %	
Nb	Co
0.01	0.05

Exaton 25.22.2.LMn (GMAW)

Exaton 25.22.2.LMn is a manganese alloyed chromium-nickel-molybdenum filler material used for welding UNS S31050, EN 1.4466, (e.g. Alleima® 2RE69). The weld deposit has excellent low temperature toughness that makes it suitable for joining stainless steels for cryogenic service. It is used for MIG/MAG welding, plasma welding and overlay welding using hot wire TIG and mechanized TIG. Exaton 25.22.2.LMn has extensively been used successfully in all critical high-pressure units of modern urea processes, such as: Stripper tubes - Stamicarbon, Montedison IDR Outerlayer of bimetallic (stripper tubes) - Saipem Ferrules - All processes Carbamate condensers - All processes Decomposers - Montedison Reactor coils - UTI Exaton 25.22.2.LMn has also found extensive use in other corrosive environments in fertilizer plants, such as: – Nitric acid cooler/condensers cooled with polluted cooling water – Heating coils and pipe in NPK plants – Norsk Hydro process

Specifications	
Classifications	EN ISO 14343-A : G/W/P 25 22 2 N L SFA/AWS A5.9 : ERG Werkstoffnummer : ~ 1.4466
Approvals	CE : EN 13479 UKCA : EN 13479 VdTÜV : 03102(GTAW)

Approvals are based on factory location. Please contact ESAB for more information.

Alloy Type	Austenitic, 25% Cr - 22% Ni - 2.2% Mo - low C
Shielding Gas	M12, M13 (EN ISO 14175)

Typical Tensile Properties			
Condition	Yield Strength	Tensile Strength	Elongation
AWS			
As Welded	405 MPa	620 MPa	34 %
ISO			
As Welded	410 MPa	620 MPa	33 %

Typical Charpy V-Notch Properties		
Condition	Testing Temperature	Impact Value
AWS		
As Welded	20 °C	105 J
As Welded	-110 °C	85 J
As Welded	-196 °C	65 J
ISO		
As Welded	-196 °C	65 J

Typical Weld Metal Analysis %									
C	Mn	Si	S	P	Ni	Cr	Mo	Cu	N
AWS									
0.02	4.3	0.1	0.002	0.013	22.0	25.0	2.2	0.01	0.1
ISO									
0.02	4.3	0.1	0.003	0.012	21.9	24.8	2.2	0.01	0.1

Typical Weld Metal Analysis %			
Nb	Ti	Co	B
AWS			
0.003	0.001	0.14	0.002
ISO			
0.004	0.001	0.14	0.002

Exaton 25.22.2.LMn (GMAW)

Typical Wire Composition %

C	Mn	Si	S	P	Ni	Cr	Mo	Cu	N
0.001	4.6	0.12	0.003	0.013	22	25	2.2	0.02	0.14

Typical Wire Composition %

Nb	Co	B
0.01	0.03	0.0018

Recommended Welding Parameters

Wire Diameter	Current	Voltage	Wire Feed Speed
0.8 mm	40-120 A	15-19 V	4.0-8.0 mm/min
1.0 mm	60-220 A	15-28 V	4.0-12.0 mm/min
1.2 mm	150-260 A	24-29 V	3.0-10.0 mm/min
1.6 mm	230-350 A	25-30 V	3.0-5.0 mm/min

Exaton 27.7.5.L (GMAW)

Exaton 27.7.5.L is a Hyper duplex (austenitic-ferritic) filler metal with improved yield strength and better pitting and crevice corrosion resistance compared to Super duplex stainless steels (UNS S32750 and S32760). It also has higher HISC (hydrogen induced stress cracking) resistance compared to Super duplex stainless steels and higher resistance to aggressively sour environments. Exaton 27.7.5.L can be advantageously used for welding 13% Cr flow pipes, as its high strength enables reduction of repair rates during pipeline production, because finite element analysis is not required for weld metal of matching strength and the acceptance criteria can be less conservative. The high pitting resistance of Exaton 27.7.5.L makes it suitable for root pass welding of UNS S32750 (e.g. SAF™ 2507), UNS S32760 and other Super duplex stainless steels when the risk of pitting corrosion is critical, or when mixed shielding gases cannot be used. Exaton 27.7.5.L can be used for plasma welding, but primarily used for overlay welding using hot wire TIG and mechanized TIG e.g. tube sheets in heat exchangers or for joint welding of Hyper duplex, UNS S32707 (SAF™ 2707 HD), pipe.

Specifications

Classifications	EN ISO 14343-A : G/W/P Z 27 7 5 L
Approvals	CE : EN 13479 UKCA : EN 13479

Approvals are based on factory location. Please contact ESAB for more information.

Alloy Type	Austenitic-ferritic (duplex) with approx. 65% ferrite - 27% Cr - 6.5 %Ni - 5% Mo - Low C
Shielding Gas	N2 (EN ISO 14175)

Typical Tensile Properties

Condition	Yield Strength	Tensile Strength	Elongation
AWS			
As Welded	755 MPa	905 MPa	27 %
ISO			
As Welded	770 MPa	900 MPa	24.5 %

Typical Charpy V-Notch Properties

Condition	Testing Temperature	Impact Value
AWS		
As Welded	20 °C	126 J
ISO		
As Welded	20 °C	126 J

Typical Weld Metal Analysis %

C	Mn	Si	S	P	Ni	Cr	Mo	V	N
ISO									
0.018	0.9	0.3	0.002	0.016	6.4	26.6	4.5	0.06	0.3
AWS									
0.017	0.9	0.3	0.002	0.016	6.5	26.7	4.5	0.06	0.3

Typical Weld Metal Analysis %

Nb	Ti	Co	PRE	W
ISO				
0.003	0.001	0.7	46	0.01
AWS				
0.003	0.001	0.7	46	0.01

Typical Wire Composition %

C	Mn	Si	S	P	Ni	Cr	Mo	V	Cu
0.015	1.0	0.3	0.0007	0.017	6.5	27	5.0	0.07	0.15

Exaton 27.7.5.L (GMAW)

Typical Wire Composition %

N	Nb	Ti	Co	PRE	W
0.4	0.01	0.001	1	49	0.02

Recommended Welding Parameters

Wire Diameter	Current	Voltage	Wire Feed Speed
0.8 mm	40-120 A	15-19 V	4.0-8.0 mm/min
1.2 mm	150-260 A	24-29 V	3.0-10.0 mm/min

Exaton 27.31.4.LCu (GMAW)

Exaton 27.31.4.LCu is a copper alloyed chromium-nickel-molybdenum filler material for MIG welding of high-alloy austenitic stainless steels, such as UNS S08028 / 1.4563 (e.g. Sanicro 28®). It is also suitable for joining UNS N08825 / 2.4858 (e.g. Sanicro 41®) and other similar materials. Due to its outstanding corrosion properties, Exaton 27.31.4.LCu can be used in the most diverse environments, such as contaminated phosphoric acid, sulphuric acid, nitric acid, sour gas service in the oil & gas industry and chloride bearing seawater. Typical applications are found in heat exchangers, evaporators and transport piping. Exaton 27.31.4.LCu GMAW can also be used for plasma welding and overlay welding using hot wire TIG and mechanical TIG. For mechanical properties of weld overlay using GTAW, please refer to the PDS of Exaton 27.31.4.LCu GTAW.

Specifications

Classifications	EN ISO 14343-A : G/W/P 27 31 4 Cu L SFA/AWS A5.9 : ER383
Approvals	CE : EN 13479 UKCA : EN 13479

Approvals are based on factory location. Please contact ESAB for more information.

Alloy Type	Austenitic, 27% Cr - 31% Ni - 3.5% Mo - 1.0% Cu - low C
Shielding Gas	I1 (EN ISO 14175)

Typical Tensile Properties

Condition	Yield Strength	Tensile Strength	Elongation
AWS			
As Welded	380 MPa	580 MPa	40 %
ISO			
As Welded	400 MPa	590 MPa	40 %

Typical Charpy V-Notch Properties

Condition	Testing Temperature	Impact Value
AWS		
As Welded	20 °C	185 J
As Welded	-196 °C	135 J
ISO		
As Welded	20 °C	180 J
As Welded	-196 °C	145 J

Typical Weld Metal Analysis %

C	Mn	Si	S	P	Ni	Cr	Mo	Al	Cu
0.012	1.6	0.05	0.001	0.011	30.4	26.8	3.4	0.02	0.75

Typical Weld Metal Analysis %

Nb	Co
0.02	0.01

Typical Wire Composition %

C	Mn	Si	S	P	Ni	Cr	Mo	Al	Cu
0.01	1.7	0.1	0.001	0.012	31.0	27.0	3.5	0.04	1.0

Typical Wire Composition %

N	Nb	Co
0.05	0.02	0.03

Exaton 27.31.4.LCu (GMAW)

Recommended Welding Parameters			
Wire Diameter	Current	Voltage	Wire Feed Speed
1.0 mm	60-220 A	15-28 V	4.0-12.0 mm/min
1.2 mm	150-260 A	24-29 V	3.0-10.0 mm/min
1.6 mm	230-350 A	25-30 V	3.0-5.0 mm/min

Exaton 29.8.2.L (GMAW)

Exaton 29.8.2.L is used for MIG/MAG welding of the super-duplex grade SAF™ 2906, SAF™ 3006 and other similar grades. Typical applications are welding of piping systems and heat exchangers later exposed for acids such as hydrochloric acid (HCl), sulfuric acid (H₂SO₄), organic acids and formic acid (HCOOH). It can also be used in alumina production. Due to its high chromium content, Exaton 29.8.2.L has very good resistance in caustic environments such as sodium hydroxide (NaOH) and potassium hydroxide (KOH). It can be used for plasma welding and overlay welding using hot wire TIG and mechanized TIG.

Specifications

Classifications	EN ISO 14343-A : G/W/P Z 29 8 2 L
Approvals	CE : EN 13479 UKCA : EN 13479

Approvals are based on factory location. Please contact ESAB for more information.

Alloy Type	Austenitic-ferritic (duplex) with approx. 50 FN ferrite - 29% Cr - 7% Ni - 2% Mo - Low C
Shielding Gas	N ₂ (EN ISO 14175)

Typical Tensile Properties

Condition	Yield Strength	Tensile Strength	Elongation
AWS			
As Welded	730 MPa	850 MPa	25 %
ISO			
As Welded	750 MPa	860 MPa	25 %

Typical Charpy V-Notch Properties

Condition	Testing Temperature	Impact Value
AWS		
As Welded	20 °C	155 J
ISO		
As Welded	20 °C	165 J

Typical Weld Metal Analysis %

C	Mn	Si	S	P	Ni	Cr	Mo	Cu	N
AWS									
0.018	0.9	0.3	0.001	0.018	6.7	29	2.2	0.13	0.3
ISO									
0.017	0.9	0.3	0.001	0.018	6.7	29	2.2	0.14	0.3

Typical Weld Metal Analysis %

Nb	Ti	Co	PRE
AWS			
0.003	0.001	0.07	41.3
ISO			
0.003	0.001	0.07	41.3

Typical Wire Composition %

C	Mn	Si	S	P	Ni	Cr	Mo	Cu	N
<0.025	1.0	0.4	0.0005	0.015	7	29	2.2	0.11	0.3

Typical Wire Composition %

Nb	Ti	Co	PRE

Exaton 29.8.2.L (GMAW)

Typical Wire Composition %

Nb	Ti	Co	PRE
0.01	0.003	0.07	41.7

Recommended Welding Parameters

Wire Diameter	Current	Voltage	Wire Feed Speed
1.2 mm	150-260 A	24-29 V	3.0-10.0 mm/min

Exaton AXT (GMAW)

Exaton AXT is a filler metal of AWS ER 307 type with increased manganese content, reducing the risk for fissuring / hot cracking that otherwise can be a problem in fully austenitic weld metals. It is suitable for joining work-hardenable steels, armor plates, austenitic stainless manganese steels and free-machining steels (such as ASTM 303) and stainless cr steels with max 18% Cr.

Specifications	
Classifications	EN ISO 14343 : G 18 8 Mn SFA/AWS A5.9 : ER(307) modified
Approvals	CE : EN 13479 CWB DB : 43.118.10

Approvals are based on factory location. Please contact ESAB for more information.

Typical Tensile Properties			
Condition	Yield Strength	Tensile Strength	Elongation
As Welded	460 MPa	650 MPa	41 %

Typical Charpy V-Notch Properties		
Condition	Testing Temperature	Impact Value
As Welded	20 °C	140 J
As Welded	-196 °C	27 J

Typical Wire Composition %									
C	Mn	Si	S	P	Ni	Cr	Mo	Cu	N
0.08	7	0.9	<=0.015	<=0.025	8	18	<=0.3	<=0.1	<=0.06

Exaton SAFUREX (GMAW)

SAFUREX GMAW is used for MIG/MAG welding of the super-duplex grade Safurex®, also known as Alleima Safurex®. It is a highly corrosion-resistant material specially developed for the Stamicarbon urea process. Suitable for the severe conditions in strippers in urea production, Safurex® is designed to enable an oxygenless process that increases output and safety. It can be used for plasma welding and overlay welding using hot wire TIG and mechanized TIG.

Specifications	
Classifications	EN ISO 14343-A : G/W/P Z 29 8 2 L
Approvals	CE : EN 13479 UKCA : EN 13479

Approvals are based on factory location. Please contact ESAB for more information.

Alloy Type	Austenitic-ferritic (duplex) with approx. 50 FN ferrite - 29% Cr - 7% Ni - 2% Mo - Low C
Shielding Gas	N2 (EN ISO 14175)

Typical Weld Metal Analysis %									
C	Mn	Si	S	P	Ni	Cr	Mo	Cu	N
0.013	1.1	0.23	0.001	0.019	8.0	29.1	2.5	0.10	0.3

Typical Weld Metal Analysis %	
Co	PRE
0.03	42

Typical Wire Composition %									
C	Mn	Si	S	P	Ni	Cr	Mo	Cu	N
<0.025	1.0	0.4	0.0005	0.015	7	29	2.2	0.11	0.3

Typical Wire Composition %				
Nb	Ti	Co	PRE	
0.01	0.003	0.07	41.7	

Recommended Welding Parameters			
Wire Diameter	Current	Voltage	Wire Feed Speed
1.2 mm	150-260 A	24-29 V	3.0-10.0 mm/min

Exaton SX (GMAW)

Exaton SX is a high silicon containing austenitic stainless steel wire for joining grades, such as UNS S32615 (e.g. Alleima® SX). The wire is developed for use in concentrated sulfuric acid and in high concentrated nitric acid. Exaton SX is used for joining and overlay welding with MIG, plasma and hot wire TIG and mechanical TIG.

Specifications

Classifications	EN ISO 14343-A : G/W/P Z 18 13 Si Cu L
Approvals	CE : EN 13479 UKCA : EN 13479

Approvals are based on factory location. Please contact ESAB for more information.

Alloy Type	Austenitic - 19%Cr 13%Ni 5%Si 2%Cu - Low C
Shielding Gas	I1 (EN ISO 14175)

Typical Tensile Properties

Condition	Yield Strength	Tensile Strength	Elongation
As Welded	327 MPa	668 MPa	55 %

Typical Wire Composition %

C	Mn	Si	S	P	Ni	Cr	Mo	Cu	N
0.01	1.7	4.9	0.002	0.011	13.5	18.5	0.02	2.0	0.06

Typical Wire Composition %

Nb	Co
0.01	0.02

Deposition Data

Diameter	Current	Voltage	Wire Feed Speed	Deposition Rate
0.9 mm	65-220 A	15-28 V	3.5-18.0 m/min	1.1-5.4 kg/h

Recommended Welding Parameters

Wire Diameter	Current	Voltage	Wire Feed Speed
1.6 mm	230-350 A	25-30 V	3.0-5.0 mm/min

Exaton 19.9.L (GTAW)

Exaton 19.9.L is suitable for joining stainless steels of the 18Cr/8Ni/ELC and 18Cr/8Ni/Nb types for service temperatures up to 350 °C (662 °F). It is also suitable for welding equipment intended to be used in cryogenic applications and the product is approved by TÜV to be used down to 4K (-269 °C (-452 °F)). Typical cryogenic applications: manufacturing of dewars, containers, tanks, cryostats and transfer systems for transportation and storage of LNG, LPG, liquid nitrogen and liquid helium. Exaton 19.9.L meets the requirements of ASME Section VIII, Division 1, UHA 51 ((a) (3) (-a) (-1)) and others. The chemical composition is optimized for cryogenic applications in terms of impact strength, lateral expansion and other characteristics. The controlled chemical composition and ferrite content are optimized for resistance to microfissuring, and balanced minor additions of certain elements for optimum arc stability, fluidity and low spatter. It is used for joining and overlay welding.

Specifications	
Classifications	EN ISO 14343-A : W 19 9 L SFA/AWS A5.9 : ER308L Werkstoffnummer : ~ 1.4316
Approvals	CE : EN 13479 UKCA : EN 13479 VdTÜV : 00064

Approvals are based on factory location. Please contact ESAB for more information.

Typical Tensile Properties			
Condition	Yield Strength	Tensile Strength	Elongation
As Welded	420 MPa	570 MPa	41 %
As Welded 50 °C	310 MPa	410 MPa	29 %
As Welded 00 °C	290 MPa	440 MPa	25 %

Typical Charpy V-Notch Properties		
Condition	Testing Temperature	Impact Value
As Welded	20 °C	145 J
As Welded	-196 °C	75 J
As Welded	-196 °C	90 J
As Welded	-269 °C	40 J

Typical Weld Metal Analysis %									
C	Mn	Si	S	P	Ni	Cr	Mo	Cu	N
0.011	1.9	0.3	0.008	0.018	10.1	19.6	0.3	0.15	0.06

Typical Weld Metal Analysis %			
Nb	Ti	Co	FN WRC-92
0.01	0.003	0.05	6

Typical Wire Composition %									
C	Mn	Si	S	P	Ni	Cr	Mo	Cu	N
0.019	1.7	0.4	0.012	0.022	10.6	19.8	0.2	0.2	0.06

Typical Wire Composition %				
Nb	Ti	Co	FN deLong	FN WRC-92
0.02	0.004	0.07	6	7

Exaton 19.9.LSi (GTAW)

Exaton 19.9.LSi GTAW is used for joining stainless steels of the 18Cr/8Ni ELC-type and 18Cr/8Ni/Nb type for service temperatures up to 350°C (660°F). It is also used for overlay welding.

Specifications

Classifications	EN ISO 14343-A : W 19 9 L Si SFA/AWS A5.9 : ER308LSi Werkstoffnummer : ~ 1.4316
Approvals	CE : EN 13479 DB : 43.118.01 UKCA : EN 13479 VdTÜV : 00869

Approvals are based on factory location. Please contact ESAB for more information.

Alloy Type	Austenitic (with approx. 8 % ferrite) 19% Cr - 9% Ni - Low C - High Si
Shielding Gas	I1 (EN ISO 14175)

Typical Tensile Properties

Condition	Yield Strength	Tensile Strength	Elongation
As Welded	390 MPa	600 MPa	42 %
As Welded 400 °C	290 MPa	440 MPa	24 %

Typical Charpy V-Notch Properties

Condition	Testing Temperature	Impact Value
As Welded	20 °C	135 J
As Welded	-196 °C	50 J

Typical Weld Metal Analysis %

C	Mn	Si	S	P	Ni	Cr	Mo	Cu	N
0.02	1.7	0.7	0.010	0.020	10.3	19.6	0.02	0.13	0.06

Typical Weld Metal Analysis %

Nb	FN WRC-92
0.01	8

Typical Wire Composition %

C	Mn	Si	S	P	Ni	Cr	Mo	Cu	N
0.013	1.8	0.9	0.011	0.021	10	20	0.2	0.2	0.06

Typical Wire Composition %

Nb	Ti	Co	FN WRC-92
0.01	0.004	0.10	9

Exaton 19.12.3.L CRYO (GTAW)

Exaton 19.12.3.L CRYO is a filler material for joining austenitic stainless steels, e.g. ASTM 316, 316L, as well as 304, 304L, for cryogenic applications and meets the requirements of ASME Section VIII, Division 1, UHA 51 ((a) (4) (-a) (-1)) and others. It is used for service temperatures down to -269°C (-452°F), and ferritic or martensitic stainless steels, with maximum 19% Cr. The grade has been specifically developed for welding in cryogenic applications, typically: manufacturing of dewars, containers, tanks, cryostats, and transfer systems for transportation and storage of LNG, LPG, liquid nitrogen and liquid helium. It is used for joining and overlay welding. The chemical composition is optimized for cryogenic applications in terms of impact strength and other characteristics. It has controlled chemical composition and ferrite content for resistance to microfissuring, and balanced minor additions of certain elements for optimum arc stability and wetting characteristics. Impurity levels are lower in the consumable in order to reduce the risk of hot cracking and to obtain the best arc stability, fluidity, low spatter and wetting properties.

Specifications	
Classifications	EN ISO 14343-A : W (19 12 3 L) SFA/AWS A5.9 : ER316L Werkstoffnummer : ~1.4430 EN ISO 14343-B : SS316L
Approvals	CE : EN 13479 UKCA : EN 13479

Approvals are based on factory location. Please contact ESAB for more information.

Alloy Type	Austenitic (with appr. 2 % ferrite) 19 % Cr - 13 % Ni - 2 % Mo - Low C
Shielding Gas	I1 (EN ISO 14175)

Typical Tensile Properties			
Condition	Yield Strength	Tensile Strength	Elongation
As welded ISO			
As Welded	460 MPa	590 MPa	35 %
As Welded AWS			
As Welded	440 MPa	570 MPa	-

Typical Charpy V-Notch Properties		
Condition	Testing Temperature	Impact Value
As welded ISO		
As Welded	-196 °C	80 J

Typical Weld Metal Analysis %									
C	Mn	Si	S	P	Ni	Cr	Mo	Al	Cu
0.01	1.8	0.4	0.002	0.015	12.5	18.2	2.3	0.01	0.08

Typical Weld Metal Analysis %				
N	Nb	Ti	Co	FN WRC-92
0.05	0.01	0.005	0.04	3.5

Typical Wire Composition %									
C	Mn	Si	S	P	Ni	Cr	Mo	Al	Cu
0.02	1.8	0.4	0.003	0.012	13.3	18.5	2.3	0.01	0.06

Typical Wire Composition %				
N	Nb	Ti	Co	FN WRC-92
0.06	0.01	0.005	0.03	2

Exaton 19.12.3.LSiMo (GTAW)

Exaton 19.12.3.LSiMo is used for welding of austenitic stainless alloys of 18% Cr - 8% Ni and 18% Cr - 10% Ni - 3% Mo-types, stabilized or non-stabilized, e.g. ASTM 316, 316L and 316Ti as well as 304, 304L, 321 and 347, for service temperatures up to 400°C (750°F). It is also used for welding of stainless Cr-steels with max 19% Cr. Exaton 19.12.3.LSiMo is particularly suited for GMAW, but can also be used for automated GTAW and plasma welding. The critical pitting temperature, CPT, according to ASTM G150 (1°C of accuracy) can be as high as 39°C compared to standard 316LSi, which achieved maximum 29°C during the benchmark. The results were achieved with GMAW, but are expected to be on the same level or better for GTAW.

Specifications	
Classifications	EN ISO 14343-A : W 19 12 3 L Si SFA/AWS A5.9 : 316LSi Werkstoffnummer : ~1.4430
Approvals	CE : EN 13479 UKCA : EN 13479

Approvals are based on factory location. Please contact ESAB for more information.

Alloy Type	Austenitic (with appr. 9 % ferrite) 19 % Cr - 12 % Ni - 3 % Mo - Low C - High Si
Shielding Gas	I1 (EN ISO 14175)

Typical Charpy V-Notch Properties		
Condition	Testing Temperature	Impact Value
As Welded	20 °C	150 J
As Welded	-196 °C	50 J

Typical Weld Metal Analysis %									
C	Mn	Si	S	P	Ni	Cr	Mo	Cu	N
0.01	1.8	0.9	0.007	0.017	12	18.8	2.8	0.1	0.06

Typical Weld Metal Analysis %		
Nb	Co	FN WRC-92
0.02	0.05	9

Typical Wire Composition %									
C	Mn	Si	S	P	Ni	Cr	Mo	Cu	N
0.013	1.8	0.9	0.010	0.018	12	18.5	2.9	0.10	0.05

Typical Wire Composition %			
Nb	Ti	Co	FN WRC-92
0.04	0.002	0.05	9

Exaton 19.13.4.L (GTAW)

Exaton 19.13.4.L is suitable for joining stainless CrNiMo steels e.g. 317L or similar. It's corrosion resistance is better than 316L and used in corrosive environments where crevice and pitting corrosion are of concern.

Specifications	
Classifications	EN ISO 14343-A : W 19 13 4 L SFA/AWS A5.9 : ER317L Werkstoffnummer : 1.4438*

Alloy Type	Austenitic 19 % Cr - 13.5 % Ni - 3.5 % Mo - Low C
Shielding Gas	11 (EN ISO 14175)

Typical Tensile Properties			
Condition	Yield Strength	Tensile Strength	Elongation
As Welded	380 MPa	600 MPa	42 %

Typical Charpy V-Notch Properties		
Condition	Testing Temperature	Impact Value
As Welded	20 °C	140 J

Typical Weld Metal Analysis %								
C	Mn	Si	S	P	Ni	Cr	Mo	N
0.021	1.71	0.36	0.014	0.010	13.0	18.7	3.05	0.056

Typical Wire Composition %									
C	Mn	Si	S	P	Ni	Cr	Mo	Cu	N
0.01	1.4	0.4	0.01	0.02	13.7	18.9	3.6	0.11	0.04

Typical Wire Composition %
FN WRC-92
8

Exaton 20.25.5.LCu (GTAW)

Exaton 20.25.5.LCu welding wire is suitable for joining stainless steels, such as UNS N08904 (e.g. Alleima® 2RK65™) used in many areas of the process industry like production of acetic acid, sulfuric acid, terephthalic or tartaric acid and vinyl chloride. It is also suitable for use in cooling operations involving sea water or heavily polluted river water.

Specifications	
Classifications	EN ISO 14343-A : W 20 25 5 Cu L SFA/AWS A5.9 : ER385 Werkstoffnummer : ~1.4519
Approvals	CE : EN 13479 UKCA : EN 13479 VdTÜV : 02223

Approvals are based on factory location. Please contact ESAB for more information.

Alloy Type	Austenitic, 20% Cr, 25% Ni, 4.5% Mo, 1.5% Cu, low C
Shielding Gas	I1, I3, R1 (EN ISO 14175)

Typical Tensile Properties			
Condition	Yield Strength	Tensile Strength	Elongation
As Welded 0 °C	440 MPa	585 MPa	35 %
As Welded+ 00 °C	315 MPa	430 MPa	33 %

Typical Charpy V-Notch Properties		
Condition	Testing Temperature	Impact Value
As Welded	20 °C	200 J
As Welded	-196 °C	160 J

Typical Weld Metal Analysis %									
C	Mn	Si	S	P	Ni	Cr	Mo	Al	Cu
0.02	1.8	0.3	0.001	0.014	24.8	19.8	4.3	0.01	1.4

Typical Weld Metal Analysis %		
N	Nb	Co
0.06	0.01	0.1

Typical Wire Composition %									
C	Mn	Si	S	P	Ni	Cr	Mo	Al	Cu
0.01	1.8	0.3	0.002	0.013	25	20	4.3	0.02	1.5

Typical Wire Composition %			
N	Nb	Ti	Co
0.05	0.01	0.003	0.1

Exaton 22.8.3.L (GTAW)

Exaton 22.8.3.L is designed for gas shielded arc welding of duplex stainless steels, such as UNS S32304 (e.g. SAF™ 2304) and UNS S31803 / S32205 (e.g. SAF™ 2205). Its corrosion resistance is equal to UNS N08904 (e.g. Alleima® 2RK65™) in most applications. It combines high strength with excellent ductility. Exaton 22.8.3.L can also be used for joining UNS S32304 and UNS S31803 / S32205 to carbon steel or low-alloy steels.

Specifications	
Classifications	EN ISO 14343-A : W 22 9 3 N L SFA/AWS A5.9 : ER2209 EN ISO 14343-B : 2209
Approvals	ABS : 0.8-4.0mm BV : 2.4-3.2mm CE : EN 13479 DB : 43.118.13 DNV : 2.0-4.0mm UKCA : EN 13479 VdTÜV : 19480

Approvals are based on factory location. Please contact ESAB for more information.

Alloy Type	Austenitic-ferritic (duplex) with approx. 55 FN ferrite - 22.5% Cr - 8% Ni - 3% Mo - Low C
Shielding Gas	I1, I2, I3, N2 (EN ISO 14175)

Typical Tensile Properties			
Condition	Yield Strength	Tensile Strength	Elongation
As Welded	580 MPa	710 MPa	28 %

Typical Charpy V-Notch Properties		
Condition	Testing Temperature	Impact Value
As Welded	20 °C	200 J
As Welded	-20 °C	180 J
As Welded	-40 °C	160 J
As Welded	-46 °C	155 J
As Welded	-50 °C	145 J

Typical Weld Metal Analysis %									
C	Mn	Si	S	P	Ni	Cr	Mo	V	Cu
0.01	1.5	0.5	0.001	0.02	8.5	23	3.1	0.05	0.1

Typical Weld Metal Analysis %						
N	Nb	Ti	Co	PRE	FN WRC-92	W
0.16	0.01	0.003	0.04	35.8	54	0.01

Typical Wire Composition %									
C	Mn	Si	S	P	Ni	Cr	Mo	V	Cu
0.012	1.5	0.5	0.0007	0.018	8.6	23	3.2	0.05	0.09

Typical Wire Composition %						
N	Nb	Ti	Co	PRE	FN WRC-92	W
0.15	0.01	0.003	0.04	37	55	0.01

Exaton 22.8.3.LSi (GTAW)

Exaton 22.8.3.LSi is designed for gas shielded arc welding of duplex stainless steels, such as UNS S32304 (e.g. SAF™ 2304) and UNS S31803 / S32205 (e.g. SAF™ 2205). Its corrosion resistance is equal to UNS N08904 (e.g. Alleima® 2RK65™) in most applications. It combines high strength with excellent ductility. Exaton 22.8.3.LSi can also be used for joining UNS S32304 and UNS S31803 / S32205 to carbon steel or low-alloy steels. It is used for joining and overlay welding.

Specifications	
Classifications	EN ISO 14343-A : W 22 9 3 N L SFA/AWS A5.9 : ER2209 EN ISO 14343-B : 2209
Approvals	CE : EN 13479 UKCA : EN 13479 VdTÜV : 10055

Approvals are based on factory location. Please contact ESAB for more information.

Alloy Type	Austenitic-ferritic (duplex) with approx. 55 FN ferrite - 22.5% Cr - 8% Ni - 3% Mo - Low C + Si
Shielding Gas	I1, I3, N2 (EN ISO 14175)

Typical Tensile Properties			
Condition	Yield Strength	Tensile Strength	Elongation
As Welded	580 MPa	710 MPa	28 %

Typical Charpy V-Notch Properties		
Condition	Testing Temperature	Impact Value
As Welded	20 °C	200 J
As Welded	-20 °C	180 J
As Welded	-46 °C	155 J
As Welded	-50 °C	145 J

Typical Weld Metal Analysis %									
C	Mn	Si	S	P	Ni	Cr	Mo	Cu	N
0.01	1.5	0.8	0.001	0.02	8.5	23	3.1	0.1	0.16

Typical Weld Metal Analysis %			
Nb	PRE	FN WRC-92	W
0.01	35.8	54	0.01

Typical Wire Composition %									
C	Mn	Si	S	P	Ni	Cr	Mo	V	Cu
0.012	1.5	0.8	0.0007	0.018	8.6	23	3.2	0.05	0.09

Typical Wire Composition %						
N	Nb	Ti	Co	PRE	FN WRC-92	W
0.15	0.01	0.003	0.04	37	55	0.01

Exaton 22.12.HT (GTAW)

Exaton 22.12.HT is an austenitic stainless steel filler material for welding high temperature steel grades, such as UNS 30815, EN 1.4835 (e.g. Alleima® 253 MA). It is characterized by high creep strength, good resistance to oxidation and good weldability.

Specifications	
Classifications	EN ISO 14343-A : W 21 10 N EN 10088-1 : 1.4835
Approvals	CE : EN 13479 UKCA : EN 13479

Approvals are based on factory location. Please contact ESAB for more information.

Alloy Type	Austenitic (with appr. 9 % ferrite) - 21% Cr - 10% Ni - Low C
Shielding Gas	I1 (EN ISO 14175)

Typical Tensile Properties			
Condition	Yield Strength	Tensile Strength	Elongation
@ 20°C			
As Welded	560 MPa	725 MPa	40 %
@ 900°C			
As Welded+	140 MPa	165 MPa	38 %

Typical Charpy V-Notch Properties		
Condition	Testing Temperature	Impact Value
As Welded	20 °C	135 J
As Welded	-60 °C	60 J
As Welded	-110 °C	30 J

Typical Weld Metal Analysis %									
C	Mn	Si	S	P	Ni	Cr	Mo	Al	Cu
0.07	0.6	1.6	0.0007	0.023	9.9	20.8	0.08	0.003	0.06

Typical Weld Metal Analysis %							
N	Nb	Ti	Co	B	FN deLong	Ce	
0.14	0.005	0.002	0.04	0.0003	10	0.04	

Typical Wire Composition %									
C	Mn	Si	S	P	Ni	Cr	Mo	Al	Cu
0.07	0.5	1.6	0.0007	0.020	10.2	21.0	0.1	0.01	0.1

Typical Wire Composition %							
N	Nb	Ti	Co	B	FN deLong	Ce	
0.17	0.01	0.005	0.05	0.0008	9	0.04	

Exaton 24.13.LHF (GTAW)

Exaton 24.13.LHF welding wire is suitable for TIG overlay welding and joining dissimilar steels, for example austenitic stainless steels to low alloyed or non alloyed steels. It has excellent resistance to hot cracking due to its enhanced ferrite content.

Specifications

Classifications	EN ISO 14343-A : W 23 12 L SFA/AWS A5.9 : ER309L
Approvals	CE : EN 13479 UKCA : EN 13479 VdTUV : 00936

Approvals are based on factory location. Please contact ESAB for more information.

Alloy Type	Austenitic (with approx. 14 % ferrite) 24 % Cr - 13 % Ni - Low C
Shielding Gas	I1, I3, R1 (EN ISO 14175)

Typical Tensile Properties

Condition	Yield Strength	Tensile Strength	Elongation
As Welded	475 MPa	565 MPa	35 %

Typical Charpy V-Notch Properties

Condition	Testing Temperature	Impact Value
As Welded	20 °C	175 J
As Welded	-40 °C	160 J
As Welded	-60 °C	150 J

Typical Weld Metal Analysis %

C	Mn	Si	S	P	Ni	Cr	Mo	V	Cu
0.01	1.8	0.3	0.001	0.014	13.6	23.7	0.02	0.04	0.01

Typical Weld Metal Analysis %

N	Nb	Co	FN deLong	FN WRC
0.05	0.01	0.02	14	13

Typical Wire Composition %

C	Mn	Si	S	P	Ni	Cr	Mo	V	Cu
0.01	1.8	0.4	0.001	0.011	13.4	23.5	0.04	0.05	0.03

Typical Wire Composition %

N	Nb	Ti	Co	FN deLong	FN WRC
0.05	0.03	0.004	0.03	14	13

Exaton 25.10.4.L (GTAW)

Exaton 25.10.4.L is designed for gas shielded arc welding of superduplex stainless steels, such as UNS S32750 (e.g. SAF™ 2507), UNS S32760 and UNS S31803 / S32205 (e.g. SAF™ 2205). It combines high strength with excellent ductility. Exaton 25.10.4.L can also be used for joining UNS S32750 and S32760 to carbon steel or low-alloy steels. Exaton 25.10.4.L can also be used for welding duplex stainless steels when the highest possible corrosion resistance is required. The grade is characterized by excellent resistance to stress corrosion cracking in chloride-bearing environments and excellent resistance to pitting and crevice corrosion. Its corrosion resistance is equal to UNS S31254 (e.g. Alleima® 254SMO™) in most applications.

Specifications	
Classifications	EN ISO 14343-A : W 25 9 4 N L SFA/AWS A5.9 : ER2594
Approvals	ABS : 2594 BV : Duplex CE : EN 13479 DNV-GL : 1.2 - 3.2 mm UKCA : EN 13479 VdTUV : 06592

Approvals are based on factory location. Please contact ESAB for more information.

Alloy Type	Austenitic-ferritic (duplex) with approx. 50 FN ferrite - 25% Cr - 10% Ni - 4% Mo - Low C
Shielding Gas	I1, I3, N2 (EN ISO 14175)

Typical Tensile Properties			
Condition	Yield Strength	Tensile Strength	Elongation
As Welded	650 MPa	850 MPa	25 %

Typical Charpy V-Notch Properties		
Condition	Testing Temperature	Impact Value
As Welded	20 °C	210 J
As Welded	-40 °C	170 J
As Welded	-46 °C	150 J
As Welded	-50 °C	140 J

Typical Weld Metal Analysis %									
C	Mn	Si	S	P	Ni	Cr	Mo	Cu	N
0.01	0.4	0.4	0.001	0.02	9.5	25	3.9	0.1	0.24

Typical Weld Metal Analysis %			
Nb	PRE	FN WRC-92	W
0.01	41.7	52	0.01

Typical Wire Composition %									
C	Mn	Si	S	P	Ni	Cr	Mo	V	Cu
0.012	0.4	0.3	0.0005	0.015	9.5	25	4	0.05	0.07

Typical Wire Composition %							
N	Nb	Ti	Co	PRE	FN WRC-92	W	
0.25	0.01	0.003	0.04	42	50	0.01	

Exaton 25.20.L (GTAW)

Exaton 25.20.L is an austenitic stainless steel filler material for joining steel grades, such as UNS 31002, EN 1.4335 (e.g. Alleima® 2RE10) and similar grades used in heavily oxidizing media such as pipes in preheaters, coolers and condensers in the chemical industry.

Specifications

Classifications	EN ISO 14343-A : W Z 25 20 L SFA/AWS A5.9 : ER310 (mod) EN 10088-1 : 1.4335
Approvals	CE : EN 13479 UKCA : EN 13479

Approvals are based on factory location. Please contact ESAB for more information.

Alloy Type	Austenitic - 24.5% Cr - 20.5% Ni - Low C
Shielding Gas	I1 (EN ISO 14175)

Typical Tensile Properties

Condition	Yield Strength	Tensile Strength	Elongation
As Welded	380 MPa	530 MPa	38 %

Typical Charpy V-Notch Properties

Condition	Testing Temperature	Impact Value
As Welded	20 °C	250 J
As Welded	-196 °C	200 J

Typical Weld Metal Analysis %

C	Mn	Si	S	P	Ni	Cr	Mo	Cu	N
0.01	1.6	0.06	0.001	0.017	20.2	24.2	0.07	0.01	0.03

Typical Weld Metal Analysis %

Nb	Co
0.02	0.04

Typical Wire Composition %

C	Mn	Si	S	P	Ni	Cr	Mo	Cu	N
0.01	1.7	0.1	0.0005	0.014	20.4	24.5	0.1	0.01	0.05

Typical Wire Composition %

Nb	Co
0.01	0.05

Exaton 25.22.2.LMn (GTAW)

Exaton 25.22.2.LMn is a manganese alloyed chromium-nickel-molybdenum filler material used for welding UNS S31050, EN 1.4466, (e.g. Alleima® 2RE69). The weld deposit has excellent low temperature toughness that makes it suitable for joining stainless steels for cryogenic service. Exaton 25.22.2.LMn has extensively been used successfully in all critical high-pressure units of modern urea processes, such as: Stripper tubes - Stamicarbon, Montedison IDR Outerlayer of bimetallic (stripper tubes) - Saipem Ferrules - All processes Carbamate condensers - All processes Decomposers - Montedison Reactor coils - UTI Exaton 25.22.2.LMn has also found extensive use in other corrosive environments in fertilizer plants, such as: – Nitric acid cooler/condensers cooled with polluted cooling water – Heating coils and pipe in NPK plants – Norsk Hydro process

Specifications	
Classifications	EN ISO 14343-A : W 25 22 2 N L SFA/AWS A5.9 : ERG Werkstoffnummer : ~ 1.4466
Approvals	CE : EN 13479 UKCA : EN 13479 VdTÜV : 03102

Approvals are based on factory location. Please contact ESAB for more information.

Alloy Type	Austenitic, 25% Cr - 22% Ni - 2.2% Mo - low C
Shielding Gas	I1 (EN ISO 14175)

Typical Tensile Properties			
Condition	Yield Strength	Tensile Strength	Elongation
As Welded	335 MPa	580 MPa	42 %
PWHT 400 °C	225 MPa	410 MPa	29 %

Typical Charpy V-Notch Properties		
Condition	Testing Temperature	Impact Value
As Welded	20 °C	120 J
As Welded	-196 °C	100 J

Typical Weld Metal Analysis %									
C	Mn	Si	S	P	Ni	Cr	Mo	Cu	N
0.011	4.4	0.10	0.002	0.012	21.9	25.1	2.2	0.04	0.12

Typical Weld Metal Analysis %		
Nb	Co	B
0.01	0.03	0.0016

Typical Wire Composition %									
C	Mn	Si	S	P	Ni	Cr	Mo	Cu	N
0.010	4.6	0.12	0.003	0.013	22	25	2.2	0.02	0.14

Typical Wire Composition %		
Nb	Co	B
0.01	0.03	0.0018

Exaton 27.7.5.L (GTAW)

Exaton 27.7.5.L is a Hyper duplex (austenitic-ferritic) filler metal with improved yield strength and better pitting and crevice corrosion resistance compared to Super duplex stainless steels (UNS S32750 and S32760). It also has higher HISC (hydrogen induced stress cracking) resistance compared to Super duplex stainless steels and higher resistance to aggressively sour environments. Exaton 27.7.5.L can be advantageously used for welding 13% Cr flow pipes, as its high strength enables reduction of repair rates during pipeline production, because finite element analysis is not required for weld metal of matching strength and the acceptance criteria can be less conservative. The high pitting resistance of Exaton 27.7.5.L makes it suitable for root pass welding of UNS S32750 (e.g. SAF™ 2507), UNS S32760 and other Super duplex stainless steels when the risk of pitting corrosion is critical. Exaton 27.7.5.L is used for joining, plasma welding and for overlay welding using hot wire TIG and mechanized TIG. For example tube sheet welding in heat exchangers or for joint welding of Hyper duplex, UNS S32707 (SAF™ 2707 HD), pipe.

Specifications

Classifications	EN ISO 14343-A : W Z 27 7 5 L
Approvals	CE : EN 13479 UKCA : EN 13479

Approvals are based on factory location. Please contact ESAB for more information.

Alloy Type	Austenitic-ferritic (duplex) with approx. 60% ferrite - 27% Cr - 6.5 %Ni - 5% Mo - Low C
Shielding Gas	N2 (EN ISO 14175)

Typical Tensile Properties

Condition	Yield Strength	Tensile Strength	Elongation
As Welded	750 MPa	900 MPa	27 %

Typical Charpy V-Notch Properties

Condition	Testing Temperature	Impact Value
As Welded	20 °C	190 J
As Welded	-20 °C	160 J
As Welded	-50 °C	44 J

Typical Weld Metal Analysis %

C	Mn	Si	S	P	Ni	Cr	Mo	V	Cu
0.015	1.0	0.3	0.0005	0.015	6.5	26.6	4.8	0.06	0.2

Typical Weld Metal Analysis %

N	Nb	Co	PRE	W
0.3	0.002	0.8	47	0.01

Typical Wire Composition %

C	Mn	Si	S	P	Ni	Cr	Mo	V	Cu
0.015	1.0	0.3	0.0007	0.017	6.5	27	5	0.07	0.15

Typical Wire Composition %

N	Nb	Ti	Co	PRE	W
0.4	0.01	0.001	1	49	0.02

Exaton 27.31.4.LCu (GTAW)

Exaton 27.31.4.LCu is a copper alloyed chromium-nickel-molybdenum filler material for welding of high-alloy austenitic stainless steels such as Sanicro 28 (UNS S08028, 1.4563) type. It is also suitable for joining Sanicro 41 (UNS N08825, 2.4858) and other similar materials. Exaton 27.31.4.LCu GTAW is used for joining and overlay welding. Due to its outstanding corrosion properties, Exaton 27.31.4.LCu can be used in the most diverse environments, such as phosphoric and sulphuric acid, sour gas service in the oil & gas industry and chloride bearing seawater. Typical applications are found in heat exchangers, evaporators and transport piping.

Specifications	
Classifications	EN ISO 14343-A : W 27 31 4 Cu L SFA/AWS A5.9 : ER383
Approvals	CE : EN 13479 UKCA : EN 13479 VdTÜV : 02629

Approvals are based on factory location. Please contact ESAB for more information.

Alloy Type	Austenitic, 27% Cr - 31% Ni - 3.5% Mo - 1.0% Cu - low C
Shielding Gas	I1, R1 (EN ISO 14175)

Typical Tensile Properties			
Condition	Yield Strength	Tensile Strength	Elongation
As Welded 20 °C	440 MPa	600 MPa	35 %
As Welded+ 550 °C	270 MPa	390 MPa	35 %

Typical Charpy V-Notch Properties		
Condition	Testing Temperature	Impact Value
As Welded	20 °C	200 J
As Welded	-196 °C	140 J

Typical Weld Metal Analysis %									
C	Mn	Si	S	P	Ni	Cr	Mo	Al	Cu
0.012	1.7	0.05	0.001	0.01	30.5	26.7	3.5	0.03	1.1

Typical Weld Metal Analysis %		
N	Nb	Co
0.05	0.01	0.04

Typical Wire Composition %									
C	Mn	Si	S	P	Ni	Cr	Mo	Al	Cu
0.01	1.7	0.1	0.001	0.012	31.0	27.0	3.5	0.04	1.0

Typical Wire Composition %		
N	Nb	Co
0.05	0.02	0.03

Exaton 29.8.2.L (GTAW)

Exaton 29.8.2.L is used for TIG welding of the super-duplex grade SAF™ 2906, SAF™ 3006 and other similar grades. Typical applications are welding of piping systems and heat exchangers later exposed for acids such as hydrochloric acid (HCl), sulfuric acid (H₂SO₄), organic acids and formic acid (HCOOH). It can also be used in alumina production. Due to its high chromium content, Exaton 29.8.2.L has very good resistance in caustic environments such as sodium hydroxide (NaOH) and potassium hydroxide (KOH).

Specifications

Classifications	EN ISO 14343-A : W Z 29 8 2 L
Approvals	CE : EN 13479 UKCA : EN 13479

Approvals are based on factory location. Please contact ESAB for more information.

Alloy Type	Austenitic-ferritic (duplex) with approx. 50 FN ferrite - 29% Cr - 7% Ni - 2% Mo - Low C
Shielding Gas	N ₂ (EN ISO 14175)

Typical Tensile Properties

Condition	Yield Strength	Tensile Strength	Elongation
AWS			
As Welded	730 MPa	880 MPa	25 %
ISO			
As Welded	750 MPa	870 MPa	25 %

Typical Charpy V-Notch Properties

Condition	Testing Temperature	Impact Value
AWS		
As Welded	20 °C	165 J
ISO		
As Welded	20 °C	180 J

Typical Weld Metal Analysis %

C	Mn	Si	S	P	Ni	Cr	Mo	Cu	N
ISO									
0.02	0.9	0.3	0.001	0.017	6.7	29	2.2	0.14	0.3
AWS									
0.016	0.9	0.3	0.001	0.017	6.7	29	2.2	0.14	0.2

Typical Weld Metal Analysis %

Nb	Ti	Co	PRE
ISO			
0.003	0.001	0.07	41.1
AWS			
0.003	0.001	0.07	40.1

Typical Wire Composition %

C	Mn	Si	S	P	Ni	Cr	Mo	Cu	N
<0.025	1.0	0.4	0.0005	0.015	7	29	2.2	0.11	0.3

Typical Wire Composition %

Nb	Ti	Co	PRE

Exaton SAFUREX (GTAW)

Exaton SAFUREX GTAW is used for TIG welding of the super-duplex grade Safurex®, also known as Alleima Safurex®. It is a highly corrosion-resistant material specially developed for the Stamicarbon urea process. Suitable for the severe conditions in strippers in urea production, Safurex® is designed to enable an oxygenless process that increases output and safety. Exaton SAFUREX GTAW is used for joining and overlay welding.

Specifications	
Classifications	EN ISO 14343-A : W Z 29 8 2 L
Approvals	CE : EN 13479 UKCA : EN 13479

Approvals are based on factory location. Please contact ESAB for more information.

Alloy Type	Austenitic-ferritic (duplex) with approx. 50 FN ferrite - 29% Cr - 7% Ni - 2% Mo - Low C
Shielding Gas	N2 (EN ISO 14175)

Typical Tensile Properties			
Condition	Yield Strength	Tensile Strength	Elongation
As Welded	670 MPa	880 MPa	25 %

Typical Charpy V-Notch Properties		
Condition	Testing Temperature	Impact Value
As Welded	20 °C	150 J

Typical Weld Metal Analysis %									
C	Mn	Si	S	P	Ni	Cr	Mo	Cu	N
0.01	1.1	0.2	0.001	0.018	8.0	28.9	2.5	0.10	0.4

Typical Weld Metal Analysis %			
Nb	Ti	Co	PRE
0.003	0.001	0.04	43

Typical Wire Composition %									
C	Mn	Si	S	P	Ni	Cr	Mo	Cu	N
<0.025	1.0	0.4	0.0005	0.015	7	29	2.2	0.11	0.3

Typical Wire Composition %			
Nb	Ti	Co	PRE
0.01	0.003	0.07	41.7

Exaton SX (GTAW)

Exaton SX is a high silicon containing austenitic stainless steel wire for joining grades, such as UNS S32615 (e.g. Alleima® SX). The wire is developed for use in concentrated sulfuric acid and in high concentrated nitric acid. Exaton SX GTAW is used for joining and overlay welding.

Specifications

Classifications	EN ISO 14343-A : W Z 18 13 Si Cu L
Approvals	CE : EN 13479 UKCA : EN 13479

Approvals are based on factory location. Please contact ESAB for more information.

Alloy Type	Austenitic - 19%Cr 13%Ni 5%Si 2%Cu - Low C
Shielding Gas	I1, I3 (EN ISO 14175)

Typical Tensile Properties

Condition	Yield Strength	Tensile Strength	Elongation
As Welded	420 MPa	750 MPa	35 %

Typical Charpy V-Notch Properties

Condition	Testing Temperature	Impact Value
As Welded	20 °C	50 J

Typical Weld Metal Analysis %

C	Mn	Si	S	P	Ni	Cr	Mo	Cu	N
0.01	1.7	4.8	0.001	0.014	13.2	18.4	0.03	1.9	0.04

Typical Weld Metal Analysis %

Nb	Co
0.01	0.03

Typical Wire Composition %

C	Mn	Si	S	P	Ni	Cr	Mo	Cu	N
0.01	1.7	4.9	0.002	0.011	13.5	18.5	0.02	2.0	0.06

Typical Wire Composition %

Nb	Co
0.01	0.02

Arcaloy MC18CrCb

Arcaloy MC18CrCb is an 18% Cr alloy metal cored electrode stabilized with Titanium (Ti) and Niobium (Nb). It is designed for welding Armo 18Cr-Cb HP-10TM stainless steels used in catalytic converters, manifolds, mufflers, and exhaust systems. It is also suited for welding parts with poor fit up. Arcaloy MC18CrCb produces a smooth spray-type metal transfer with very minimal spatter.

Specifications

Classifications	AWS A5.22 : EC439Nb
------------------------	---------------------

Alloy Type	MC18CrCb
-------------------	----------

Typical Weld Metal Analysis %

C	Mn	Si	S	P	Cr	Nb	Ti
0.02	0.70	0.51	0.02	0.01	18.60	0.50	0.25

Deposition Data

Diameter	Current	Voltage	Wire Feed Speed	Electrical Stickout
1.2 mm	200 A	20 V	533 cm/min	12.7 mm
1.2 mm	215 A	21 V	584 cm/min	12.7 mm
1.2 mm	234 A	22 V	635 cm/min	12.7 mm
1.2 mm	290 A	24 V	762 cm/min	12.7 mm
1.2 mm	323 A	24 V	889 cm/min	12.7 mm

Recommended Welding Parameters

Wire Diameter	Current	Voltage	Wire Feed Speed
1.2 mm	200-323 A	20-24 V	5.33-8.89 mm/min

Arcaloy MC409Ti

Arcaloy MC409Ti is a 12% Cr alloy metal cored electrode stabilized with Titanium (Ti) for arc stability and to improve corrosion resistance, increase strength at high temperatures, and promote the ferritic microstructure. Arcaloy MC409Ti produces a smooth spray-type metal transfer with very minimal spatter. It is particularly suited for welding parts with poor fit up. It was designed for welding stainless steel catalytic converters, manifolds, mufflers, and exhaust systems.

Specifications

Classifications	SFA/AWS A5.22 : EC409
------------------------	-----------------------

Typical Weld Metal Analysis %

C	Mn	Si	S	P	Cr	Ti
0.02	0.72	0.27	0.01	0.01	11.90	1.00

Deposition Data

Diameter	Current	Voltage	Wire Feed Speed	Electrical Stickout
1.2 mm	200 A	20 V	533 cm/min	12.7 mm
1.2 mm	215 A	21 V	584 cm/min	12.7 mm
1.2 mm	234 A	22 V	635 cm/min	12.7 mm
1.2 mm	290 A	24 V	762 cm/min	12.7 mm
1.2 mm	323 A	24 V	889 cm/min	12.7 mm

Recommended Welding Parameters

Wire Diameter	Current	Voltage	Wire Feed Speed
1.2 mm	200-323 A	20-24 V	5.33-8.89 mm/min

Arcaloy MC439Ti

Arcaloy MC439Ti is an 16-17% Cr alloy metal cored electrode stabilized with Titanium (Ti). The high level of chromium provides additional oxidation and corrosion resistance when welding stainless steel catalytic converters, manifolds, mufflers, and exhaust systems. It is also suited for welding parts with poor fit up. Arcaloy MC439Ti produces a spray - type metal transfer with minimal spatter.

Specifications

Classifications	SFA/AWS A5.22 : EC439
Welding Current	DC+
Alloy Type	MC439Ti
Shielding Gas	M13 (EN ISO 14175)

Typical Weld Metal Analysis %

C	Mn	Si	S	P	Cr	Ti
0.02	0.76	0.27	0.01	0.01	17.90	0.68

Deposition Data

Diameter	Current	Voltage	Wire Feed Speed	Electrical Stickout
1.2 mm	200 A	20 V	533 cm/min	12.7 mm
1.2 mm	215 A	21 V	584 cm/min	12.7 mm
1.2 mm	234 A	22 V	635 cm/min	12.7 mm
1.2 mm	290 A	24 V	762 cm/min	12.7 mm
1.2 mm	323 A	24 V	889 cm/min	12.7 mm

Recommended Welding Parameters

Wire Diameter	Current	Voltage	Wire Feed Speed
1.2 mm	200-323 A	20-24 V	5.23-8.89 mm/min

FILARC PZ6163

A metal cored wire alloyed with 17%Cr and 1% Mo used with M21 shielding gas.

Specifications	
Classifications	EN 14700 : T Fe7 DIN 8555 : MF5-400GC
Welding Current	DC+

Typical Weld Metal Analysis %				
C	Mn	Si	Cr	Mo
0.17	0.53	0.83	16.6	1.08

Deposition Data				
Diameter	Current	Voltage	Wire Feed Speed	Deposition Rate
1.6 mm	150-450 A	21-40 V	2.4-11.9 m/min	1.8-9.0 kg/h

FILARC PZ6166

A metal cored wire for the fabrication and repair of Pelton and Francis wheels and other water turbine components in 13%Cr 4%Ni alloyed soft martensitic steels used with M12 or M13 shielding gas.

Specifications

Classifications	EN 14700 : T Fe7 EN ISO 17633-A : T 13 4 M M12 2 EN ISO 17633-A : T 13 4 M M13 2
------------------------	--

Welding Current	DC+
Shielding Gas	M12, M13 (EN ISO 14175)

Typical Tensile Properties

Condition	Yield Strength	Tensile Strength	Elongation
M12			
PWHT 2 hour(s) 580-600 °C	681 MPa	835 MPa	18.7 %

Typical Charpy V-Notch Properties

Condition	Testing Temperature	Impact Value
M12		
PWHT 2 hour(s) 580-600 °C	-20 °C	51 J

Typical Weld Metal Analysis %

C	Mn	Si	Ni	Cr	Mo
M12					
0.021	1.13	0.72	4.43	12.8	0.43

Deposition Data

Diameter	Current	Voltage	Wire Feed Speed	Deposition Rate
1.2 mm	150-350 A	18-34 V	5.3-16.4 m/min	2.2-7.0 kg/h
1.6 mm	150-450 A	18-39 V	2.4-11.2 m/min	1.8-10.0 kg/h

OK Tubrod 15.31

A metal cored 316L stainless steel cored wire for use with mixed shielding gas.

Specifications	
Classifications	AWS A5.22 : EC316L EN ISO 17633-A : T 19 12 3 L M M12 2 EN ISO 17633-A : T 19 12 3 L M M13 2
Approvals	CE : EN 13479 DB : 43.039.07 DNV : NV 316L (M12) LR : 316L S (M13) UKCA : EN 13479 VdTÜV : 03171

Approvals are based on factory location. Please contact ESAB for more information.

Welding Current	DC+
Alloy Type	Austenitic 316L
Shielding Gas	M12, M13 (EN ISO 14175)

Deposition Data				
Diameter	Current	Voltage	Wire Feed Speed	Deposition Rate
1.2 mm	150-350 A	18-34 V	5.3-16.4 m/min	2.2-7.0 kg/h
1.6 mm	150-450 A	18-39 V	2.4-11.2 m/min	1.8-10.0 kg/h

OK Tubrod 15.34

A metal cored 307L stainless steel cored wire for use with M13 shielding gas.

Specifications	
Classifications	EN 14700 : T Fe10 EN ISO 17633-A : T 18 8 Mn M M12 2 EN ISO 17633-A : T 18 8 Mn M M13 2 EN ISO 17633-A : T 18 8 Mn M M21 2
Approvals	CE : EN 13479 DB : 43.039.03 UKCA : EN 13479 VdTUV : 04335

Approvals are based on factory location. Please contact ESAB for more information.

Welding Current	DC+
Alloy Type	307
Shielding Gas	M12, M13, M21 (EN ISO 14175)

Deposition Data				
Diameter	Current	Voltage	Wire Feed Speed	Deposition Rate
1.2 mm	150-350 A	18-34 V	5.3-16.4 m/min	2.2-7.0 kg/h

OK Tubrod 15.37

A metal cored duplex stainless steel cored wire for use with M21 or M13 shielding gas.

Specifications

Classifications	EN 14700 : T Fe11 SFA/AWS A5.9 : EC2209 EN ISO 17633-A : T 22 9 3 N L M M12 2 EN ISO 17633-A : T 22 9 3 N L M M13 2
Approvals	CE : EN 13479 UKCA : EN 13479 VdTÜV : 09775

Approvals are based on factory location. Please contact ESAB for more information.

Welding Current	DC+
Alloy Type	Duplex
Shielding Gas	M12, M13 (EN ISO 14175)

Typical Weld Metal Analysis %

C	Mn	Si	Ni	Cr	Mo	N
0.016	0.78	0.63	8.6	21.7	2.8	0.13

Deposition Data

Diameter	Current	Voltage	Wire Feed Speed	Deposition Rate
1.2 mm	150-350 A	18-34 V	5.3-16.4 m/min	2.2-7.0 kg/h

Shield-Bright 308H

FCAW wire for 18%Cr - 8%Ni stainless steel, For all-position welding. Shield-Bright 308H was developed for welding Type 304H stainless steel and can also be used for welding Type 301, 302, and 304 steels. It contains a higher carbon level than 308L filler metals to give greater high temperature strength. The ferrite content is also lower for high temperature service. It has greater ductility than 347 types at high temperatures and for that reason it is sometimes used to weld Types 321 and 347 for service above 750°F(399°C)coupled with high stress. Shield-Bright 308H was designed for welding in all positions and performs particularly well in the vertical position with excellent slag removal.

Specifications	
Classifications	SFA/AWS A5.22 : E308HT1-1 SFA/AWS A5.22 : E308HT1-4 JIS Z 3323 : YF 308C KS D 3612 : YF 308C EN ISO 17633-A : T 19 9 H P C1 2 EN ISO 17633-A : T 19 9 H P M21 2 JIS Z 3232 : TS308H-FB1
Industry	Power Generation Petrochemical Industrial and General Fabrication

Welding Current	DC+
Alloy Type	C Cr Ni
Shielding Gas	M21, C1 (EN ISO 14175)

Typical Tensile Properties			
Condition	Yield Strength	Tensile Strength	Elongation
M21 Shielding Gas			
As Welded	430 MPa	600 MPa	42 %
C1 Shielding Gas			
As Welded	392 MPa	578 MPa	44 %

Typical Charpy V-Notch Properties		
Condition	Testing Temperature	Impact Value
M21 Shielding Gas		
As Welded	-29 °C	50 J
As Welded	-196 °C	28 J
C1 Shielding Gas		
As Welded	-29 °C	47 J
As Welded	-196 °C	26 J

Typical Weld Metal Analysis %						
C	Mn	Si	S	P	Ni	Cr
M21 Shielding Gas						
0.060	1.20	0.90	0.007	0.020	9.8	19.5
C1 Shielding Gas						
0.050	1.10	0.80	0.007	0.020	9.5	19.3

Deposition Data				
Diameter	Current	Voltage	Wire Feed Speed	Deposition Rate
1.2 mm	130-220 A	24-29 V	5.8-14.4 m/min	1.9-4.6 kg/h

Shield-Bright 308L

FCAW wire for 18%Cr - 8%Ni stainless steel, For all-position welding. For welding types 301, 302, 304, 304L, 308 and 308L of stainless steel. May be used for welding types 321 and 347 if service temperature does not exceed 500°F(260°C). Low carbon content minimizes carbide precipitation. Ferrite values will lower as impact toughness increases. Carbon content 0.04% maximum.

Specifications	
Classifications	SFA/AWS A5.22 : E308LT1-1 SFA/AWS A5.22 : E308LT1-4 JIS Z 3323 : YF 308LC KS D 3612 : YF 308LC EN ISO 17633-A : T 19 9 L P C1 2 EN ISO 17633-A : T 19 9 L P M21 2
Approvals	ABS : E308LT1-4 ABS : E308LT1-1 BV : 308L (C1) BV : SA 308L (M21) CCS : 308L (C1) CE : EN 13479 ClassNK : KW308LG(C) CWB : E308LT1-1 (M21) CWB : E308LT1-4 (C1) DNV : VL 308L (M21) KR : RW308LG (C) (C1) LR : 304L RS : A-5 (x3CrNi 19 11) UKCA : EN 13479 VdTÜV : 04832 (M20,M21)

Approvals are based on factory location. Please contact ESAB for more information.

Welding Current	DC+
Alloy Type	C Cr Ni
Shielding Gas	M21, C1 (EN ISO 14175)

Typical Tensile Properties			
Condition	Yield Strength	Tensile Strength	Elongation
C1			
As Welded	372 MPa	568 MPa	61 %
M21			
As Welded	410 MPa	580 MPa	44 %

Typical Charpy V-Notch Properties		
Condition	Testing Temperature	Impact Value
C1		
As Welded	-29 °C	60 J
As Welded	-196 °C	30 J
M21		
As Welded	-29 °C	50 J
As Welded	-196 °C	28 J

Typical Weld Metal Analysis %						
C	Mn	Si	S	P	Ni	Cr
C1						
0.025	1.10	0.70	0.007	0.025	10.0	19.1

Shield-Bright 308L

Typical Weld Metal Analysis %

C	Mn	Si	S	P	Ni	Cr
M21						
0.030	1.20	0.90	0.007	0.025	10.1	19.3

Deposition Data

Diameter	Current	Voltage	Wire Feed Speed	Deposition Rate
1.2 mm	130-220 A	24-29 V	5.8-14.4 m/min	1.9-4.6 kg/h

Shield-Bright 308L X-tra

FCAW wire for 18%Cr - 8%Ni stainless steel, For flat and horizontal position welding. Designed for welding types 301, 302, 304, 304L, 308, 308L steels. Ideal where service temperatures are below 500°F(260°C). Low carbon content helps minimize carbide precipitation. Carbon content 0.04% maximum.

Specifications	
Classifications	SFA/AWS A5.22 : E308LT0-1 SFA/AWS A5.22 : E308LT0-4 JIS Z 3323 : TS308L-FB0 KS D 3612 : YF308LC EN ISO 17633-A : T 19 9 L R C1 3 EN ISO 17633-A : T 19 9 L R M21 3
Approvals	ABS : E308LT0-1 BV : 308L (M21) CE : EN 13479 CWB : E308LT0-1 (M21) CWB : E308LT0-4 (C1) DNV-GL : VL 308L (C1) KR : RW308LG(C) (C1) LR : 304L UKCA : EN 13479 VdTÜV : 06611

Approvals are based on factory location. Please contact ESAB for more information.

Welding Current	DC+
Alloy Type	C Cr Ni
Shielding Gas	M21, C1 (EN ISO 14175)

Typical Tensile Properties			
Condition	Yield Strength	Tensile Strength	Elongation
M21 Shielding Gas			
As Welded	410 MPa	580 MPa	40 %
C1 shielding gas			
As Welded	409 MPa	549 MPa	55 %

Typical Charpy V-Notch Properties		
Condition	Testing Temperature	Impact Value
M21 Shielding Gas		
As Welded	-29 °C	40 J
As Welded	-196 °C	24 J

Typical Weld Metal Analysis %						
C	Mn	Si	S	P	Ni	Cr
C1 shielding gas						
0.030	1.30	0.48	0.004	0.020	9.8	19.4
M21 Shielding Gas						
0.022	1.40	0.90	0.004	0.020	9.9	19.6

Deposition Data				
Diameter	Current	Voltage	Wire Feed Speed	Deposition Rate
1.2 mm	150-250 A	25-32 V	8.0-16.0 m/min	2.5-7.0 kg/h
1.6 mm	200-350 A	26-34 V	4.0-11.0 m/min	3.0-7.5 kg/h

Shield-Bright 309L

FCAW wire for 22%Cr - 12%Ni stainless steel. For all-position welding. Designed for welding type 309 wrought or cast forms, but used extensively for welding type 304 to mild or carbon steel. Also used for welding 304 clad sheets and for applying stainless steel sheet linings to carbon steel. Carbon content 0.04% maximum.

Specifications	
Classifications	SFA/AWS A5.22 : E309LT1-1 SFA/AWS A5.22 : E309LT1-4 JIS Z 3323 : YF-309LC KS D 3612 : YF-309LC EN ISO 17633-A : T 23 12 L P C1 2 EN ISO 17633-A : T 23 12 L P M21 2
Approvals	ABS : E309LT1-1 ABS : E309LT1-4 BV : 309L (C1) BV : SA 309L (M21) CCS : 309L (C1) CE : EN 13479 ClassNK : KW309LG(C) CWB : E 309LT1-1 (M21) CWB : E 309LT1-4 (C1) DNV : VL 309L (M21) KR : RW309LG(C) (C1) LR : SS/CMn UKCA : EN 13479 VdTÜV : 04833 (M20,M21)

Approvals are based on factory location. Please contact ESAB for more information.

Welding Current	DC+
Alloy Type	C Cr Ni
Shielding Gas	M21, C1 (EN ISO 14175)

Typical Tensile Properties			
Condition	Yield Strength	Tensile Strength	Elongation
C1			
As Welded	368 MPa	543 MPa	44 %
M21			
As Welded	377 MPa	559 MPa	39 %

Typical Charpy V-Notch Properties		
Condition	Testing Temperature	Impact Value
C1		
As Welded	-29 °C	55 J
As Welded	-196 °C	18 J
M21		
As Welded	-29 °C	45 J
As Welded	-196 °C	15 J

Typical Weld Metal Analysis %						
C	Mn	Si	S	P	Ni	Cr
C1						
0.029	1.10	0.80	0.007	0.024	12.4	23.1
M21						
0.030	1.30	0.90	0.007	0.024	12.5	23.5



Shield-Bright 309L

Deposition Data

Diameter	Current	Voltage	Wire Feed Speed	Deposition Rate
1.2 mm	130-220 A	24-29 V	5.8-14.4 m/min	1.9-4.6 kg/h

Shield-Bright 309L X-tra

FCAW wire for 22%Cr - 12%Ni stainless steel For flat and horizontal position welding. Developed to be used when welding most mild or carbon steels to type 304. The higher percentages of Cr and Ni provide the necessary crack resistance. Carbon content 0.04% maximum.

Specifications	
Classifications	SFA/AWS A5.22 : E309LT0-1 SFA/AWS A5.22 : E309LT0-4 JIS Z 3323 : YF-309LC KS D 3612 : YF-309LC EN ISO 17633-A : T 23 12 L R C1 3 EN ISO 17633-A : T 23 12 L R M21 3
Approvals	ABS : E309LT0-1 BV : 309L (C1) CCS : 309LS (C1) CE : EN 13479 CWB : E309LT0-1 (M21) CWB : E309LT0-4 (C1) DNV : VL 309L MS (C1) DNV : VL 309L MS (M21) UKCA : EN 13479 VdTÜV : 06594

Approvals are based on factory location. Please contact ESAB for more information.

Welding Current	DC+
Alloy Type	C Cr Ni
Shielding Gas	M21, C1 (EN ISO 14175)

Typical Tensile Properties			
Condition	Yield Strength	Tensile Strength	Elongation
M21 Shielding Gas			
As Welded	480 MPa	600 MPa	35 %
C1 shielding Gas			
As Welded	410 MPa	546 MPa	38 %

Typical Charpy V-Notch Properties		
Condition	Testing Temperature	Impact Value
C1 shielding Gas		
As Welded	-29 °C	40 J
As Welded	-196 °C	15 J

Typical Weld Metal Analysis %						
C	Mn	Si	S	P	Ni	Cr
C1 shielding Gas						
0.032	1.46	0.66	0.004	0.021	12.8	24.50
M21 Shielding Gas						
0.030	1.44	0.80	0.004	0.020	13.0	24.50

Deposition Data				
Diameter	Current	Voltage	Wire Feed Speed	Deposition Rate
1.2 mm	150-250 A	25-32 V	8.0-16.0 m/min	2.5-7.0 kg/h
1.6 mm	200-350 A	26-34 V	4.0-11.0 m/min	3.0-7.5 kg/h

Shield-Bright 309LMo

FCAW wire for dissimilar metals, For all-position welding. Designed for welding type 316 clad steels on the first pass in cladding steels or for welding dissimilar metals such as Mo-containing austenitic stainless steels to carbon steels. Used in paper mills and in power plants. Carbon content 0.04% maximum.

Specifications	
Classifications	SFA/AWS A5.22 : E309LMoT1-1 SFA/AWS A5.22 : E309LMoT1-4 JIS Z 3323 : TS309LMo-FB1 KS D 3612 : YF309MoLC EN ISO 17633-A : T 23 12 2 L P C1 2 EN ISO 17633-A : T 23 12 2 L P M21 2
Approvals	DNV-GL : VL 309MoL KR : RW 309MoLG(C)

Approvals are based on factory location. Please contact ESAB for more information.

Welding Current	DC+
Alloy Type	C Cr Ni Mo
Shielding Gas	M21, C1 (EN ISO 14175)

Typical Tensile Properties			
Condition	Yield Strength	Tensile Strength	Elongation
M21 Shielding Gas			
As Welded	570 MPa	750 MPa	30 %
C1 Shielding Gas			
As Welded	550 MPa	715 MPa	35 %

Typical Charpy V-Notch Properties		
Condition	Testing Temperature	Impact Value
C1 Shielding Gas		
As Welded	-29 °C	50 J
As Welded	-196 °C	20 J

Typical Weld Metal Analysis %							
C	Mn	Si	S	P	Ni	Cr	Mo
C1 Shielding Gas							
0.029	1.0	0.70	0.008	0.024	12.7	22.90	2.60
M21 Shielding Gas							
0.030	1.2	0.75	0.008	0.024	13.0	23.5	2.60

Deposition Data				
Diameter	Current	Voltage	Wire Feed Speed	Deposition Rate
1.2 mm	130-220 A	24-29 V	5.8-14.4 m/min	1.9-4.6 kg/h

Shield-Bright 309LMo X-tra

FCAW wire for 22%Cr - 12%Ni – 2%Mo stainless steel For flat and horizontal position welding. Designed for welding type 316 clad steels on the first pass in cladding steels or for welding dissimilar metals such as molybdenum-containing austenitic stainless steels to carbon steels. Used in paper mills and power plants. Carbon content 0.04% maximum.

Specifications	
Classifications	SFA/AWS A5.22 : E309LMoT0-1 SFA/AWS A5.22 : E309LMoT0-4 JIS Z 3323 : YF 309MoLC - KR KS D 3612 : YF 309MoLC - KR EN ISO 17633-A : T 23 12 2 L R C1 3 EN ISO 17633-A : T 23 12 2 L R M21 3
Industry	Industrial and General Fabrication Process Pulp and Paper

Welding Current	DC+
Alloy Type	C Cr Ni Mo
Shielding Gas	M21, C1 (EN ISO 14175)

Typical Tensile Properties			
Condition	Yield Strength	Tensile Strength	Elongation
M21 Shielding Gas			
As Welded	550 MPa	690 MPa	30 %
C1 shielding Gas			
As Welded	527 MPa	662 MPa	33 %

Typical Charpy V-Notch Properties		
Condition	Testing Temperature	Impact Value
C1 shielding Gas		
As Welded	-29 °C	28 J

Typical Weld Metal Analysis %							
C	Mn	Si	S	P	Ni	Cr	Mo
C1 shielding Gas							
0.024	1.53	0.58	0.008	0.021	13.4	24.0	2.30
M21 Shielding Gas							
0.030	1.60	0.60	0.008	0.020	13.5	23.5	2.50

Deposition Data				
Diameter	Current	Voltage	Wire Feed Speed	Deposition Rate
1.2 mm	150-250 A	25-32 V	8.0-16.0 m/min	2.5-7.0 kg/h

Shield-Bright 316L

FCAW wire for low carbon 18%Cr - 12%Ni - 2%Mo stainless steel for all-position welding. For welding type 316 stainless. Contains molybdenum which resists pitting corrosion induced by sulphuric and sulphurous acids, chlorides and cellulose solutions. Used widely in the rayon, dye and paper making industries. Carbon content 0.04% maximum.

Specifications	
Classifications	SFA/AWS A5.22 : E316LT1-1 SFA/AWS A5.22 : E316LT1-4 JIS Z 3323 : TS316L-FB1 KS D 3612 : YF 316LC EN ISO 17633-A : T 19 12 3 L P C1 2 EN ISO 17633-A : T 19 12 3 L P M21 2
Approvals	ABS : E316LT1-1 ABS : E316LT1-4 BV : 316L (C1) BV : SA 316L (M21) CE : EN 13479 ClassNK : KW316LG(C) CWB : E316LT1-1 (M21) CWB : E316LT1-4 (C1) DNV : VL 316L (M21) KR : RW316LG(C) (C1) LR : 316L RS : A-6(xCrNiMo 19 11 3) (C1) UKCA : EN 13479 VdTUV : 04834

Approvals are based on factory location. Please contact ESAB for more information.

Welding Current	DC+
Alloy Type	C Cr Ni Mo
Shielding Gas	M21, C1 (EN ISO 14175)

Typical Tensile Properties			
Condition	Yield Strength	Tensile Strength	Elongation
C1			
As Welded	442 MPa	570 MPa	53 %
M21			
As Welded	450 MPa	580 MPa	40 %

Typical Charpy V-Notch Properties		
Condition	Testing Temperature	Impact Value
C1		
As Welded	-29 °C	60 J
As Welded	-196 °C	26 J
M21		
As Welded	-29 °C	52 J
As Welded	-196 °C	25 J

Typical Weld Metal Analysis %							
C	Mn	Si	S	P	Ni	Cr	Mo
C1							
0.028	1.10	0.80	0.010	0.027	11.8	18.50	2.60
M21							

Shield-Bright 316L

Typical Weld Metal Analysis %

C	Mn	Si	S	P	Ni	Cr	Mo
0.030	1.20	0.90	0.010	0.027	12.0	18.5	2.70

Deposition Data

Diameter	Current	Voltage	Wire Feed Speed	Deposition Rate
1.2 mm	130-220 A	24-29 V	5.8-14.4 m/min	1.9-4.6 kg/h

Shield-Bright 316L X-tra

FCAW wire for 18%Cr - 12%Ni – 2%Mo stainless steel. For flat and horizontal position welding. Designed specifically for applications where the service environment can produce pitting corrosion. Commonly used in the pulp and paper industry. Carbon content 0.04% maximum.

Specifications	
Classifications	SFA/AWS A5.22 : E316LT0-1 SFA/AWS A5.22 : E316LT0-4 JIS Z 3323 : TS316L-FB0 - KR KS D 3612 : YF 316LC - KR EN ISO 17633-A : T 19 12 3 L R C1 3 EN ISO 17633-A : T 19 12 3 L R M21 3
Approvals	ABS : E316LT0-1 CE : EN 13479 CWB : E316LT0-1 (M21) CWB : E316LT0-4 (C1) DNV-GL : VL 316L (C1) KR : RW316LG (C1) LR : 316L UKCA : EN 13479 VdTÜV : 06612

Approvals are based on factory location. Please contact ESAB for more information.

Welding Current	DC+
Alloy Type	C Cr Ni Mo
Shielding Gas	M21, C1 (EN ISO 14175)

Typical Tensile Properties			
Condition	Yield Strength	Tensile Strength	Elongation
M21 Shielding Gas			
As Welded	450 MPa	580 MPa	36 %
C1 Shielding Gas			
As Welded	431 MPa	565 MPa	37 %

Typical Charpy V-Notch Properties		
Condition	Testing Temperature	Impact Value
C1 Shielding Gas		
As Welded	-29 °C	45 J
As Welded	-196 °C	20 J

Typical Weld Metal Analysis %							
C	Mn	Si	S	P	Ni	Cr	Mo
C1 shielding Gas							
0.026	1.47	0.46	0.006	0.024	12.0	18.5	2.70
M21 Shielding Gas							
0.030	1.30	0.60	0.008	0.020	12.0	19.0	2.70

Deposition Data				
Diameter	Current	Voltage	Wire Feed Speed	Deposition Rate
1.2 mm	150-250 A	25-32 V	8.0-16.0 m/min	2.5-7.0 kg/h
1.6 mm	200-350 A	26-34 V	4.0-11.0 m/min	3.0-7.5 kg/h

Shield-Bright 347

FCAW wire for 18%Cr - 8%Ni - Nb stainless steel. For all-position welding. Developed to weld types 347, 304, 304L and 321 stainless. The addition of Niobium helps minimize chromium carbide precipitation while providing improved corrosion resistance.

Specifications	
Classifications	SFA/AWS A5.22 : E347T1-1 SFA/AWS A5.22 : E347T1-4 JIS Z 3323 : TS347-FB1 KS D 3612 : YF347C EN ISO 17633-A : T 19 9 Nb P C1 2 EN ISO 17633-A : T 19 9 Nb P M21 2
Approvals	DNV-GL : VL 347 (C1) NAKS/HAKC : 1.2mm

Approvals are based on factory location. Please contact ESAB for more information.

Welding Current	DC+
Alloy Type	C Cr Ni
Shielding Gas	M21, C1 (EN ISO 14175)

Typical Tensile Properties			
Condition	Yield Strength	Tensile Strength	Elongation
C1 Shielding Gas			
As Welded	430 MPa	620 MPa	45 %

Typical Charpy V-Notch Properties		
Condition	Testing Temperature	Impact Value
C1 Shielding Gas		
As Welded	-29 °C	55 J
As Welded	-196 °C	29 J

Typical Weld Metal Analysis %	
C1 Shielding Gas	

Deposition Data				
Diameter	Current	Voltage	Wire Feed Speed	Deposition Rate
1.2 mm	130-220 A	24-29 V	5.8-14.4 m/min	1.9-4.6 kg/h

Shield-Bright 2209

Shield-Bright 2209 is an all-position duplex flux cored electrode for use with 100% CO₂ or 75–85%Ar / 20–25% CO₂ mixed gas. It is designed for the welding of 22Cr-5Ni-2Mo-0.15N duplex stainless steel(UNS S31803), commonly known as 2205. Commercial designations for such steels include SAF 2205(Sandvik), 2205 (Avesta), UR 54N(Creusot), AF22(Mannesmann), NK Cr22(Nippon Kokan), SM22Cr(Sumitomo).

Specifications	
Classifications	SFA/AWS A5.22 : E2209T1-4, E2209T1-1 EN ISO 17633-A : T 22 9 3 N L P C1 2 EN ISO 17633-A : T 22 9 3 N L P M21 2
Approvals	ABS : E2209T1-1 ABS : E2209T1-4 BV : 2205 (C1) BV : SA 2205 CCS : 2205S CE : EN 13479 CWB : E2209T1-1 (M21) CWB : E2209T1-4 (C1) DNV : Duplex DNV-GL : Duplex (C1, M21) LR : S31803 UKCA : EN 13479 VdTUV : 09123
Industry	Pipeline Process Pulp and Paper Petrochemical

Approvals are based on factory location. Please contact ESAB for more information.

Welding Current	DC+
Alloy Type	Ni, Cr, Mo, N
Shielding Gas	M21, C1 (EN ISO 14175)

Typical Tensile Properties			
Condition	Yield Strength	Tensile Strength	Elongation
C1			
As Welded	650 MPa	800 MPa	28 %
M21			
As Welded	670 MPa	810 MPa	28 %

Typical Charpy V-Notch Properties		
Condition	Testing Temperature	Impact Value
C1		
As Welded	-40 °C	40 J
M21		
As Welded	-40 °C	42 J

Typical Weld Metal Analysis %									
C	Mn	Si	S	P	Ni	Cr	Mo	N	Ferrite FN
C1									
0.03	1.40	0.60	0.012	0.025	8.7	23.2	3.21	0.14	40
M21									
0.03	0.90	0.35	0.012	0.025	9.2	22.5	3.2	0.16	40

Shield-Bright 2209

Deposition Data				
Diameter	Current	Voltage	Wire Feed Speed	Deposition Rate
1.2 mm	130-220 A	25-30 V	5.8-14.4 m/min	1.9-4.6 kg/h
1.6 mm	170-300 A	25-29 V	3.9-8.2 m/min	2.4-5.2 kg/h

Shield-Bright 2594

FCAW wire for 24%Cr - 9%Ni stainless steel, For all-position welding. Shield-Bright 2594 is designed for the welding of 25Cr-9Ni-3Mo-0.2N super duplex stainless steel (UNS S32750, S32760). It has excellent slag removal and bead shape with all position welding for use with 75%Ar+25% CO₂.

Specifications	
Classifications	SFA/AWS A5.22 : E2594T1-4 EN ISO 17633-A : T 25 9 4 N L P M21 2
Approvals	ABS : E2594T1-4 CE : EN 13479 UKCA : EN 13479
Industry	Chemical Industry Offshore Oil Petrochemical Process Pipeline Pulp and Paper

Approvals are based on factory location. Please contact ESAB for more information.

Welding Current	DC+
Alloy Type	Ni, Cr, Mo, N
Shielding Gas	M21 (EN ISO 14175)

Typical Tensile Properties			
Condition	Yield Strength	Tensile Strength	Elongation
As Welded	700 MPa	860 MPa	27 %

Typical Charpy V-Notch Properties		
Condition	Testing Temperature	Impact Value
As Welded	-29 °C	48 J
As Welded	-46 °C	44 J

Typical Weld Metal Analysis %									
C	Mn	Si	S	P	Ni	Cr	Mo	Cu	N
0.03	0.95	0.62	0.01	0.02	9.68	25.34	3.59	0.14	0.23

Typical Weld Metal Analysis %									
W									
0.02									

Deposition Data				
Diameter	Current	Voltage	Wire Feed Speed	Deposition Rate
1.2 mm	150-220 A	25-30 V	8.3-11.4 m/min	2.4-4.6 kg/h

OK Autrod 16.97

OK Autrod 16.97 is a submerged arc wire 18% Cr, 8% Ni, 6% Mn type used in a wide range of applications throughout industry, such as joining austenitic-manganese, work-hardenable steels, as well as heat-resistant steels. OK Autrod 16.97 is usually welded with OK Flux 10.93.

Specifications

Classifications	EN ISO 14343-A : S 18 8 Mn
Approvals	VdTÜV : 12101

Approvals are based on factory location. Please contact ESAB for more information.

Typical Wire Composition %

C	Mn	Si	Ni	Cr
0.07	6.5	0.4	8.2	18.9

OK Autrod 308H

A continuous solid corrosion resisting chromium-nickel wire for the welding of austenitic chromium nickel alloys of the 18% Cr - 8% Ni-type. OK Autrod 308H has a good general corrosion resistance. The alloy has a high carbon content which makes this alloy suitable for applications used at higher temperatures. The alloy is used in chemical and food processing industries as well as for pipes, tubes and boilers. OK Autrod 308H can be used in combination with OK Flux 10.93.

Specifications

Classifications	EN ISO 14343-A : S 19 9 H SFA/AWS A5.9 : ER308H
Approvals	VdTÜV : 12101

Approvals are based on factory location. Please contact ESAB for more information.

Alloy Type	Austenitic 19% Cr - 9% Ni - High C
-------------------	------------------------------------

Typical Wire Composition %

C	Mn	Si	Ni	Cr	N	Nb	FN WRC-92
0.05	1.9	0.5	9.2	19.8	0.06	0.01	9

OK Autrod 308L

A continuous solid corrosion resisting chromium-nickel wire. OK Autrod 308L has a good general corrosion resistance. The alloy has a low carbon content which makes this alloy particularly recommended where there is a risk of intergranular corrosion. The alloy is widely used in the chemical and food processing industries as well as for pipes, tubes and boilers. OK Autrod 308L can be used in combination with OK Flux 10.92, OK Flux 10.93, OK Flux 10.99 or others.

Specifications	
Classifications	EN ISO 14343-A : S 19 9 L SFA/AWS A5.9 : ER308L
Approvals	CE : EN 13479 DB : 52.039.15 UKCA : EN 13479 VdTÜV : 12101

Approvals are based on factory location. Please contact ESAB for more information.

Alloy Type	Austenitic (with approx. 10 % ferrite) 19% Cr - 9% Ni - Low C
------------	---

Typical Wire Composition %					
C	Mn	Si	Ni	Cr	N
0.02	1.9	0.4	9.8	19.8	0.05

OK Autrod 309L

A continuous solid corrosion resisting chromium-nickel wire for joining stainless steels to non-alloy or low alloy steels as well as welding of austenitic stainless alloys of 24% Cr, 13% Ni types. The wire has a good general corrosion resistance. When used for joining dissimilar materials the corrosion resistance is of secondary importance. OK Autrod 309L can be used in combination with OK Flux 10.92, OK Flux 10.93 and OK Flux 10.99.

Specifications	
Classifications	EN ISO 14343-A : S 23 12 L SFA/AWS A5.9 : ER309L
Approvals	CE : EN 13479 UKCA : EN 13479 VdTÜV : 12101

Approvals are based on factory location. Please contact ESAB for more information.

Alloy Type	Austenitic (with approx. 12 % ferrite) 24 % Cr - 13 % Ni - Low C
-------------------	--

Typical Wire Composition %								
C	Mn	Si	Ni	Cr	Mo	Cu	N	FN WRC-92
0.02	1.8	0.4	13.4	23.2	0.10	0.1	0.05	10

OK Autrod 309MoL

OK Autrod 309MoL is a stainless steel, over-alloyed wire for submerged arc welding. Suitable for joining of stainless Cr-Ni and Cr-Ni-Mo steels 304, 309 or 316 to ensure corrosion resistance in e.g. the pulp and paper industry. Dissimilar steels when alloying with Mo is essential. OK Autrod 309MoL can be used in combination with OK Flux 10.93.

Specifications

Classifications

EN ISO 14343-A : S 23 12 2 L
SFA/AWS A5.9 : ER 23 12 2 L
SFA/AWS A5.9 : ER309LMo (mod)

Typical Wire Composition %

C	Mn	Si	Ni	Cr	Mo
0.01	1.5	0.4	14.6	21.4	2.5

OK Autrod 310

A continuous solid corrosion resisting chromium-nickel wire for welding heat resistant austenitic steels of the 25% Cr, 20% Ni types. OK Autrod 310 has a good general oxidation resistance especially at high temperatures due to its high Cr content. The alloy is fully austenitic and therefore sensitive to hot cracking. Common applications are industrial furnaces and boiler parts as well as heat exchangers. OK Autrod 310 can be used in combination with OK Flux 10.90.

Specifications

Classifications

EN ISO 14343-A : S 25 20
SFA/AWS A5.9 : ER310

Alloy Type

Fully austenitic (25 % Cr - 20 % Ni)

Typical Wire Composition %

C	Mn	Si	Ni	Cr
0.10	1.6	0.4	20.7	25.8

OK Autrod 316H

A continuous solid corrosion resisting chromium-nickel-molybdenum wire for welding of austenitic stainless alloys of 17% Cr 12% Ni 3% Mo types. OK AUTROD 316H can be used in combination with OK Flux 10.93. OK Autrod 316H has a good general corrosion resistance. The alloy has a high carbon content which makes this alloy suitable for applications used at higher temperatures. The alloy is used in the chemical and food processing industries as well as for pipes, tubes and boilers.

Specifications

Classifications	EN ISO 14343-A : S 19 12 3 H SFA/AWS A5.9 : ER316H
------------------------	---

Alloy Type	Austenitic (with approx. 10 % ferrite)
-------------------	--

Typical Wire Composition %

C	Mn	Si	Ni	Cr	Mo
0.05	1.7	0.4	12.5	19.3	2.2

OK Autrod 316L

A continuous solid corrosion resisting chromium-nickel-molybdenum wire for welding of austenitic stainless alloys of 18 % Cr - 8 % Ni and 18 % Cr - 8 % Ni - 3 % Mo-types. OK Autrod 316L has a good general corrosion resistance, in particular the alloy has very good resistance against corrosion in acid and chlorinated environments. The alloy has a low carbon content which makes it particularly recommended where there is a risk of intergranular corrosion. The alloy is widely used in the chemical and food processing industries as well as in ship building and various types of architectural structures. OK Autrod 316L can be used in combination with OK Flux 10.92, OK Flux 10.93 or OK Flux 10.99.

Specifications	
Classifications	EN ISO 14343-A : S 19 12 3 L SFA/AWS A5.9 : ER316L
Approvals	CE : EN 13479 DB : 52.039.16 UKCA : EN 13479 VdTÜV : 12101

Approvals are based on factory location. Please contact ESAB for more information.

Alloy Type	Austenitic (with approx. 7% ferrite) 19%Cr - 12%Ni - 3%Mo - Low C
-------------------	---

Typical Wire Composition %									
C	Mn	Si	S	P	Ni	Cr	Mo	Cu	N
0.01	1.7	0.4	0.010	0.015	12.0	18.2	2.6	0.10	0.04

Typical Wire Composition %
FN WRC-92
7

OK Autrod 316LMn

A continuous solid corrosion resisting non-magnetic chromium-nickel-molybdenum wire for welding of stabilized and non-stabilized austenitic alloys of the same type as well as non magnetic steels. OK Autrod 316LMn can be used in combination with OK Flux 10.93 and OK Flux 10.99. The alloy is corrosion resistant in seawater environment at temperatures below 350 °C and has very good corrosion resistance to acids such as nitric acid. Excellent impact properties can be met at low temperatures.

Specifications

Classifications	EN ISO 14343-A : S 20 16 3 Mn N L SFA/AWS A5.9 : ER316LMn
------------------------	--

Alloy Type	Fully austenitic (7 % Mn - 20 % Cr - 16 % Ni - 3 % Mo - N)
-------------------	--

Typical Wire Composition %

C	Mn	Si	Ni	Cr	Mo	N
0.01	6.9	0.4	15.9	19.9	3.0	0.18

OK Autrod 317L

A continuous solid corrosion resisting chromium-nickel-molybdenum wire for welding of austenitic stainless alloys of 19% Cr 13% Ni 3% Mo types. OK Autrod 317L has a good resistance to general corrosion and pitting due to its high content of molybdenum. The alloy has a low carbon content which makes this alloy particularly recommended where there is a risk of intergranular corrosion. The alloy is used in severe corrosion conditions such as in the petrochemical and paper industries. OK Autrod 317L can be used in combination with OK Flux 10.93.

Specifications

Classifications	EN ISO 14343-A : S 18 15 3 L SFA/AWS A5.9 : ER317L
------------------------	---

Alloy Type	Austenitic (with approx. 10 % ferrite)
-------------------	--

Typical Wire Composition %

C	Mn	Si	S	P	Ni	Cr	Mo	Cu	N
0.01	1.4	0.4	0.009	0.02	13.7	19	3.6	0.11	0.05

Typical Wire Composition %

FN WRC-92

8

OK Autrod 318

OK Autrod 318 is a Nb-stabilized SAW-wire for welding stainless steels being included in AISI 316 group (i.e. 316Ti) when higher resistance to intergranular corrosion is required. The weld deposit is suitable for some corrosive environments (i.e. nitric acid) and highest working temperature is 400°C. OK Autrod 318 shall be welded in combination with OK Flux 10.92 or OK Flux 10.93.

Specifications	
Classifications	EN ISO 14343-A : S 19 12 3 Nb SFA/AWS A5.9 : ER318
Approvals	CE : EN 13479 DB : 52.039.11 UKCA : EN 13479 VdTÜV : 12101

Approvals are based on factory location. Please contact ESAB for more information.

Typical Wire Composition %								
C	Mn	Si	Ni	Cr	Mo	N	Nb	FN WRC-92
0.04	1.8	0.4	11.5	18.9	2.6	0.04	0.7	11

OK Autrod 347

A continuous solid corrosion resisting chromium-nickel wire for the welding of austenitic chromium nickel alloys of the 18% Cr - 8% Ni-type. OK Autrod 347 has a good general corrosion resistance. The alloy is stabilized with Niobium to improve the resistance against intergranular corrosion of the weld metal. Due to the niobium content this alloy is recommended for use at higher temperatures. OK Autrod 347 can be used in combination with OK Flux 10.92, OK Flux 10.93 and OK Flux 10.94.

Specifications	
Classifications	EN ISO 14343-A : S 19 9 Nb SFA/AWS A5.9 : ER347
Approvals	CE : EN 13479 DB : 52.039.07 UKCA : EN 13479 VdTUV : 12101

Approvals are based on factory location. Please contact ESAB for more information.

Alloy Type	Austenitic (with approx. 10 % ferrite) 19% Cr - 9% Ni - Nb
-------------------	--

Typical Wire Composition %							
C	Mn	Si	Ni	Cr	N	Nb	FN WRC-92
0.04	1.4	0.4	9.5	19.2	0.05	0.6	7

OK Autrod 410

A continuous solid welding wire of 13% Cr type. OK Autrod 410 is used for welding of similar martensitic and martensitic-ferritic steels in different applications. OK Autrod 410 can be used in combination with OK Flux 10.93.

Specifications

Classifications	SFA/AWS A5.9 : ER410
-----------------	----------------------

Alloy Type	Martensitic-ferritic (13 % Cr)
------------	--------------------------------

Typical Wire Composition %

C	Mn	Si	Cr
0.12	0.5	0.3	12.2

OK Autrod 410NiMo

A continuous solid corrosion resisting "410NiMo" type alloyed with 13% Cr, 4.5% Ni and 0.5% Mo. This alloy is used for welding of similar martensitic and martensitic-ferritic steels in different applications such as for example hydro-turbines. OK Autrod 410NiMo can be used in combination with OK Flux 10.93.

Specifications

Classifications	EN ISO 14343-A : S 13 4
------------------------	-------------------------

Alloy Type	Martensitic-ferritic (12 % Cr - 4.5 % Ni - 0.5 % Mo)
-------------------	--

Typical Wire Composition %

C	Mn	Si	S	P	Ni	Cr	Mo	Cu
0.02	0.43	0.37	0.004	0.017	4.5	12.2	0.4	0.07

OK Autrod 430

A continuous solid corrosion resisting 17% Cr wire for welding of stainless alloys of 13-18% Cr. OK Autrod 430 is used for cladding on un-alloyed and low alloyed steels. The wire can be used in combination with OK Flux 10.93.

Specifications

Classifications	SFA/AWS A5.9 : ER430
------------------------	----------------------

Alloy Type	Ferritic (17 % Cr)
-------------------	--------------------

Typical Wire Composition %

C	Mn	Si	Cr
0.02	0.50	0.5	18.5

OK Autrod 2209

A continuous solid corrosion resisting Duplex wire for welding of austenitic-ferritic stainless alloys of 22% Cr, 5% Ni, 3% Mo types. OK Autrod 2209 has a high general corrosion resistance. In media containing chloride and hydrogen sulphide the alloy has a high resistance to intergranular, pitting and especially to stress corrosion. The alloy is used in a variety of applications across all industrial segments. OK Autrod 2209 can be used in combination with OK Flux 10.93 or OK Flux 10.94.

Specifications

Classifications	EN ISO 14343-A : S 22 9 3 N L SFA/AWS A5.9 : ER2209
Approvals	CE : EN 13479 UKCA : EN 13479 VdTUV : 12101

Approvals are based on factory location. Please contact ESAB for more information.

Alloy Type	Austenitic-ferritic (22.5 % Cr - 8 % Ni - 3 % Mo - Low C)
-------------------	---

Typical Wire Composition %

C	Mn	Si	Ni	Cr	Mo	N	PRE	FN WRC-92
0.01	1.5	0.5	8.5	22.7	3.2	0.17	35	55

OK Autrod 2509

A continuous solid corrosion resisting "Super Duplex" wire for welding of austenitic-ferritic stainless alloys of 25% Cr, 10% Ni, 4% Mo, low C types. OK Autrod 2509 has a high intergranular corrosion resistance and pitting. The alloy is widely used in applications where corrosion resistance is of outmost importance. Pulp & paper industry, offshore and gas industry are areas of interest. OK Autrod 2509 can be used in combination with OK Flux 10.93 or OK Flux 10.94.

Specifications	
Classifications	EN ISO 14343-A : S 25 9 4 N L SFA/AWS A5.9 : ER2594
Approvals	CE : EN 13479 UKCA : EN 13479 VdTUV : 12101

Approvals are based on factory location. Please contact ESAB for more information.

Alloy Type	Austenitic-ferritic (25% Cr - 10% Ni - 4% Mo - Low C)
------------	---

Typical Wire Composition %								
C	Mn	Si	Ni	Cr	Mo	N	PRE	FN WRC-92
0.01	0.4	0.4	9.4	25.2	3.9	0.24	42	50

OK Flux 10.90

Agglomerated aluminate-fluoride-basic flux for welding of 9% Ni steels and other high alloyed steels with Ni based wires. The flux is manganese adding, which reduces the risk of hot cracking. Good slag detachability and nice bead appearance.

Specifications

Classifications	EN ISO 14174 : S A AF 2 55 53 MnNi DC
------------------------	---------------------------------------

Slag Type	Fluoride basic CaF ₂ -Al ₂ O ₃ -SiO ₂
Alloy Transfer	Chromium compensating. Nickel- and manganese alloying.
Density	nom: 1.0 kg/dm ³
Basicity Index	nom: 1.7

Flux Consumption

Volts	kg Flux / kg Wire DC+
26 V	0.5 kg
30 V	0.6 kg
34 V	0.8 kg
38 V	1.0 kg

Conditions : Dimension 4.0 mm , Amps 580 A , Travel Speed 33 m/h

Classifications	Wire	Weld Metal
Wire	SFA/AWS - EN ISO	AWS - As Welded
OK Autrod 310	A5.9:ER310 14343-A:S 25 20	-
OK Autrod NiCrMo-3	A5.14:ERNiCrMo-3 18274:S Ni 6625 (NiCr22Mo9Nb)	A5.39: F100A32-ERNiCrMo-3/G
OK Autrod NiCrMo-4	A5.14:ERNiCrMo-4 18274:S Ni 6276 (NiCr15Mo16Fe6W4)	A5.39: F100A32-ERNiCrMo-4/G

Approvals

Wire	ABS	BV	CCS	ClassNK	DNV	DNV-GL	KR	RINA
OK Autrod NiCrMo-3	-	-	-	-	-	•	-	-
OK Autrod NiCrMo-4	•	•	•	•	•	-	•	•

Typical Weld Metal Analysis %

C	Mn	Si	S	P	Ni	Cr	Mo	V	Cu
OK Autrod 310									
0.07	3.2	0.40	0.010	0.020	20.5	25.5	0.015	-	0.010
OK Autrod NiCrMo-3 DC+, 350A, 29V									
0.01	1.7	0.2	0.01	0.01	Bal.	21.0	8.5	-	-
OK Autrod NiCrMo-4 DC+, 350A, 29V									
0.01	2.2	0.2	0.03	0.01	Bal.	15.0	15.5	0.04	0.01

Typical Weld Metal Analysis %

Co	W	Fe	Nb+Ta
OK Autrod NiCrMo-3 DC+, 350A, 29V			
-	-	2.0	3.0
OK Autrod NiCrMo-4 DC+, 350A, 29V			
0.15	3.4	6.0	-



OK Flux 10.90

Typical Mechanical Properties					
Wire	Condition	Yield Strength	Tensile Strength	Elongation	Charpy V-Notch
OK Autrod 310	As Welded ISO DC+	390 MPa	570 MPa	34 %	85 J @ 20 °C
OK Autrod NiCrMo-3	As Welded HI ~1.0-1.7 kJ/mm DC+	440 MPa	720 MPa	42 %	100 J @ -196 °C
OK Autrod NiCrMo-4	As Welded DC+	480 MPa	700 MPa	40 %	60 J @ -196 °C

OK Flux 10.92

OK Flux 10.92 is an neutral, agglomerated Cr-compensating flux designed for strip cladding, butt and fillet welding of stainless and corrosion resistant steel types. Good welding characteristics and easy slag removal.

Specifications

Classifications	EN ISO 14174 : S A CS 2 57 53 DC
Welding Current	1200 A
Slag Type	Calcium silicate SiO ₂ -MgO-Al ₂ O ₃ -(CaF ₂)
Alloy Transfer	Chromium compensating
Density	nom: 1.0 kg/dm ³
Basicity Index	nom: 1.0

Flux Consumption

Volts	kg Flux / kg Wire DC+
26 V	0.4 kg
30 V	0.55 kg
34 V	0.7 kg
38 V	0.9 kg

Conditions : Dimension 4.0 mm , Amps 580 A , Travel Speed 33 m/h

Classifications	Wire	Weld Metal
Wire	SFA/AWS - EN ISO	AWS - As Welded
OK Autrod 16.97	14343-A:S 18 8 Mn	-
OK Autrod 308L	A5.9:ER308L 14343-A:S 19 9 L	-
OK Autrod 309L	A5.9:ER309L 14343-A:S 23 12 L	A5.39: F85A4-ER309L/309L
OK Autrod 316L	A5.9:ER316L 14343-A:S 19 12 3 L	A5.39: F80A10-ER316L/316L
OK Autrod 318	A5.9:ER318 14343-A:S 19 12 3 Nb	-
OK Autrod 347	A5.9:ER347 14343-A:S 19 9 Nb	-

Approvals

Wire	BV	VdTÜV
OK Autrod 308L	-	•
OK Autrod 316L	•	•
OK Autrod 318	-	•
OK Autrod 347	-	•

Typical Weld Metal Analysis %

C	Mn	Si	S	P	Ni	Cr	Mo	Cu	N
OK Autrod 16.97									
0.04	5.0	0.95	0.01	0.02	8.5	18.8	0.1	-	-
OK Autrod 308L Current: DC+, 420A, 27V									
0.02	1.0	0.9	-	-	10.0	20.0	-	-	-
OK Autrod 309L 2.4mm, DC+, 400A, 28V, 50 cm/min									
0.02	1.2	0.7	0.01	0.02	12.9	22.6	0.04	0.01	0.08

OK Flux 10.92

Typical Weld Metal Analysis %

C	Mn	Si	S	P	Ni	Cr	Mo	Cu	N
OK Autrod 316L 2.4mm: DC+, 400A, 28V, 50 cm/min.									
0.02	1.1	0.7	0.01	0.02	11.6	18.1	2.5	0.15	0.05
OK Autrod 318									
0.035	1.2	0.5	-	-	12.0	18.5	2.6	0.2	-
OK Autrod 347 Current: DC+, 420 A, 27 V									
0.040	0.9	0.75	-	-	9.7	19.8	-	-	-

Typical Weld Metal Analysis %

Nb	FN WRC-92
OK Autrod 309L 2.4mm, DC+, 400A, 28V, 50 cm/min	
-	7
OK Autrod 316L 2.4mm: DC+, 400A, 28V, 50 cm/min.	
0.01	7
OK Autrod 318	
0.3	-
OK Autrod 347 Current: DC+, 420 A, 27 V	
0.5	9

Typical Mechanical Properties

Wire	Condition	Yield Strength	Tensile Strength	Elongation	Charpy V-Notch
OK Autrod 16.97	As Welded DC+	450 MPa	630 MPa	42 %	60 J @ 20 °C 55 J @ -20 °C 45 J @ -60 °C
OK Autrod 308L	As Welded DC+	365 MPa	580 MPa	38 %	60 J @ -60 °C 50 J @ -110 °C
OK Autrod 309L	As Welded DC+	440 MPa	600 MPa	30 %	55 J @ -20 °C 50 J @ -40 °C
OK Autrod 316L	As Welded DC+	415 MPa	570 MPa	32 %	55 J @ -70 °C
OK Autrod 318	As Welded	440 MPa	600 MPa	42 %	100 J @ 20 °C 90 J @ -60 °C 40 J @ -110 °C
OK Autrod 347	As Welded DC+	470 MPa	640 MPa	35 %	65 J @ 20 °C 55 J @ -60 °C 40 J @ -110 °C

OK Flux 10.93

Basic, agglomerated flux for butt welding of stainless steels. A suitable flux for welding of high alloyed CrNi-steels like e.g. duplex stainless steel. It can also be combined with NiCrMo-3 and NiCrMo-4 wires. The low Si addition during welding provides good mechanical properties in the weld metal.

Specifications	
Classifications	EN ISO 14174 : S A AF 2 56 54 DC
Approvals	CE : EN 13479 DB : 51.039.10 UKCA : EN 13479

Approvals are based on factory location. Please contact ESAB for more information.

Slag Type	Fluoride basic CaF ₂ -Al ₂ O ₃ -SiO ₂
Alloy Transfer	Non alloying
Density	nom: 1.0 kg/dm ³
Basicity Index	nom: 1.9

Flux Consumption	
Volts	kg Flux / kg Wire DC+
26 V	0.5 kg
30 V	0.6 kg
34 V	0.8 kg
38 V	1.0 kg

Conditions : Dimension 4.0 mm , Amps 580 A , Travel Speed 33 m/h

Classifications	Wire	Weld Metal
Wire	SFA/AWS - EN ISO	AWS - As Welded
OK Autrod 16.97	14343-A:S 18 8 Mn	-
OK Autrod 2209	A5.9:ER2209 14343-A:S 22 9 3 N L	-
OK Autrod 2509	A5.9:ER2594 14343-A:S 25 9 4 N L	A5.39: F120A8-ER2594/2594
OK Autrod 308H	A5.9:ER308H 14343-A:S 19 9 H	-
OK Autrod 308L	A5.9:ER308L 14343-A:S 19 9 L	A5.39: F80A32-ER308L/308L
OK Autrod 309L	A5.9:ER309L 14343-A:S 23 12 L	A5.39: F80A10-ER309L/309L
OK Autrod 309MoL	A5.9:ER 23 12 2 L 14343-A:S 23 12 2 L; A5.9:ER309LMo (mod)	A5.39: F85A4-ER309LMo (mod)/309LMo (mod)
OK Autrod 316H	A5.9:ER316H 14343-A:S 19 12 3 H	-
OK Autrod 316L	A5.9:ER316L 14343-A:S 19 12 3 L	A5.39: F75A15-ER316L/316L
OK Autrod 316LMn	A5.9:ER316LMn 14343-A:S 20 16 3 Mn N L	-
OK Autrod 317L	A5.9:ER317L 14343-A:S 18 15 3 L	-
OK Autrod 318	A5.9:ER318 14343-A:S 19 12 3 Nb	-
OK Autrod 347	A5.9:ER347 14343-A:S 19 9 Nb	A5.39: F90A15-ER347/347
OK Autrod 410NiMo	14343-A:S 13 4	-

OK Flux 10.93

Classifications	Wire	Weld Metal
Wire	SFA/AWS - EN ISO	AWS - As Welded
OK Autrod NiCrMo-3	A5.14:ERNiCrMo-3 18274:S Ni 6625 (NiCr22Mo9Nb)	A5.39: F100A32-ERNiCrMo-3/NiCrMo-3
OK Autrod NiCrMo-4	A5.14:ERNiCrMo-4 18274:S Ni 6276 (NiCr15Mo16Fe6W4)	-

Approvals

Wire	ABS	BV	CE	DB	DNV	DNV-GL	LR	UKCA	VdTÜV
OK Autrod 2209	•	•	•	-	-	•	•	•	•
OK Autrod 2509	-	-	•	-	-	-	-	•	•
OK Autrod 308L	•	•	•	•	-	•	-	•	•
OK Autrod 309L	•	-	•	-	-	•	•	•	•
OK Autrod 316L	•	-	•	•	•	-	-	•	•
OK Autrod 318	-	-	•	•	-	-	-	•	•
OK Autrod 347	-	-	•	•	-	-	-	•	•

Typical Weld Metal Analysis %

C	Mn	Si	S	P	Ni	Cr	Mo	V	Cu
OK Autrod 16.97									
0.06	6.3	1.2	0.01	0.02	8.0	18.0	0.1	-	0.1
OK Autrod 2209 Current: DC+, 420A, 27V									
0.02	1.3	0.5	0.01	0.02	9.0	22.5	3.1	-	0.1
OK Autrod 2509 Current: DC+, 350A, 28V, 48cm/min									
0.02	0.4	0.5	0.01	0.02	9.5	24.6	3.5	-	0.2
OK Autrod 308H DC+									
0.05	1.5	0.6	0.01	0.02	9.9	19.9	0.1	-	0.1
OK Autrod 308L Current: DC+, 400A, 28V, 56cm/min									
0.02	1.6	0.5	0.01	0.02	10.0	19.5	0.2	-	0.1
OK Autrod 309L Current: DC+, 400 A, 28 V, welding speed 48cm/min									
0.02	1.3	0.5	0.01	0.02	12.5	23.0	0.2	-	0.2
OK Autrod 309MoL DC+, 380 A, 28 V, 50cm/min									
0.02	1.2	0.5	0.02	0.02	14.5	20.8	2.8	-	0.1
OK Autrod 316H DC+									
0.04	1.5	0.6	0.01	0.02	11.2	18.4	2.1	-	0.1
OK Autrod 316L Current: DC+, 350A, 28V, 48cm/min									
0.02	1.4	0.5	0.01	0.02	12.5	18.0	2.6	-	0.1
OK Autrod 316LMn									
0.02	5.4	0.7	0.01	0.01	15.5	20.0	2.5	-	0.2
OK Autrod 317L Current: DC+, 420 A, 27 V									
0.02	1.5	0.5	0.01	0.02	13.5	18.5	3.2	-	0.1
OK Autrod 318 Current: DC+, 440A, 30V									
0.035	1.2	0.5	0.01	0.02	12.0	18.5	2.6	-	0.2
OK Autrod 347 Current: DC+, 420A, 27V, welding speed 48cm/min									
0.035	1.1	0.5	0.01	0.02	9.6	19.2	0.1	-	0.2
OK Autrod 410NiMo DC+, 450A, 28V									
0.02	0.4	0.5	0.01	0.02	4.1	11.7	0.51	-	0.10
OK Autrod NiCrMo-3 Current: DC+, 400A, 28V, travel speed: 25 m/h.									

OK Flux 10.93

Typical Weld Metal Analysis %

C	Mn	Si	S	P	Ni	Cr	Mo	V	Cu
0.01	0.2	0.4	0.005	0.015	64	21.5	9	-	0.1
OK Autrod NiCrMo-4 DC+, 350A, 28V, 40cm/min									
0.01	0.4	0.20	0.002	0.006	Bal	15.1	15.6	0.1	0.03

Typical Weld Metal Analysis %

N	Nb	Co	FN WRC-92	W	Fe	Nb+Ta
OK Autrod 2209 Current: DC+, 420A, 27V						
0.17	-	-	45	-	-	-
OK Autrod 2509 Current: DC+, 350A, 28V, 48cm/min						
0.20	-	-	58	<0.002	-	-
OK Autrod 308L Current: DC+, 400A, 28V, 56cm/min						
0.06	-	-	9	-	-	-
OK Autrod 309L Current: DC+, 400 A, 28 V, welding speed 48cm/min						
-	-	-	8	-	-	-
OK Autrod 316L Current: DC+, 350A, 28V, 48cm/min						
0.047	-	-	9	-	-	-
OK Autrod 316LMn						
0.13	-	-	-	-	-	-
OK Autrod 318 Current: DC+, 440A, 30V						
-	0.3	-	9	-	-	-
OK Autrod 347 Current: DC+, 420A, 27V, welding speed 48cm/min						
-	0.5	-	8	-	-	-
OK Autrod NiCrMo-3 Current: DC+, 400A, 28V, travel speed: 25 m/h.						
-	-	0.05	-	-	5	3.3
OK Autrod NiCrMo-4 DC+, 350A, 28V, 40cm/min						
-	-	0.1	-	3.6	5.8	-

Typical Mechanical Properties

Wire	Condition	Yield Strength	Tensile Strength	Elongation	Charpy V-Notch
OK Autrod 16.97	As Welded DC+	400 MPa	600 MPa	45 %	60 J @ -20 °C
OK Autrod 2209	As Welded	630 MPa	780 MPa	30 %	140 J @ 20 °C 125 J @ -20 °C 110 J @ -40 °C 80 J @ -60 °C 28 J @ -110 °C
OK Autrod 2509	As Welded DC+	670 MPa	870 MPa	24 %	65 J @ 20 °C 40 J @ -60 °C
OK Autrod 308L	As Welded DC+	400 MPa	570 MPa	40 %	47 J @ -196 °C 100 J @ 20 °C 75 J @ -40 °C 65 J @ -60 °C 55 J @ -110 °C
OK Autrod 309L	As Welded DC+	430 MPa	570 MPa	33 %	90 J @ 20 °C 70 J @ -60 °C 60 J @ -110 °C 25 J @ -196 °C
OK Autrod 309MoL	As Welded DC+	430 MPa	610 MPa	31 %	50 J @ 20 °C 35 J @ -40 °C

OK Flux 10.93

Typical Mechanical Properties					
Wire	Condition	Yield Strength	Tensile Strength	Elongation	Charpy V-Notch
OK Autrod 316H	As Welded AWS 475A; 30V; H.I 2.0 kJ /mm DC+	410 MPa	550 MPa	40 %	85 J @ 20 °C 75 J @ 0 °C
OK Autrod 316L	As Welded DC+	420 MPa	550 MPa	42 %	100 J @ 20 °C 65 J @ -60 °C 52 J @ -110 °C 27 J @ -196 °C
OK Autrod 316LMn	As Welded 420A, 30V, 30m/h DC+	410 MPa	600 MPa	30 %	70 J @ -60 °C 60 J @ -110 °C 40 J @ -196 °C
OK Autrod 317L	As Welded DC+	440 MPa	615 MPa	28 %	80 J @ 20 °C 50 J @ -60 °C
OK Autrod 318	As Welded DC+	440 MPa	600 MPa	40 %	100 J @ 20 °C 90 J @ -60 °C 40 J @ -110 °C
OK Autrod 347	As Welded DC+	455 MPa	635 MPa	36 %	90 J @ 20 °C 85 J @ -60 °C 38 J @ -110 °C 25 J @ -196 °C
OK Autrod 410NiMo	As Welded DC+, 450A, 28V	900 MPa	1000 MPa	15.5 %	30 J @ 0 °C 30 J @ -20 °C
OK Autrod 410NiMo	Stress Relieved DC+, 500A, 30V (580 °C 4 hour(s))	785 MPa	860 MPa	18 %	55 J @ 0 °C 50 J @ -20 °C
OK Autrod 410NiMo	Stress Relieved DC+, 450A, 28V (600 °C 2 hour(s))	770 MPa	850 MPa	19 %	55 J @ 0 °C 55 J @ -20 °C
OK Autrod NiCrMo-3	As Welded DC+	450 MPa	710 MPa	45 %	80 J @ -196 °C 90 J @ -60 °C
OK Autrod NiCrMo-4	As Welded DC+	460 MPa	705 MPa	45 %	90 J @ -60 °C 85 J @ -110 °C 75 J @ -196 °C

OK Flux 10.94

Basic, chromium-compensating, agglomerated flux for butt welding of stainless steels. Specially recommended for welding of stainless steels of the superduplex type. Low Si addition during welding provides good mechanical properties in the weld metal.

Specifications	
Classifications	EN ISO 14174 : S A AF 2 56 64 DC

Slag Type	Fluoride basic CaF ₂ -Al ₂ O ₃ -SiO ₂
Alloy Transfer	Chromium compensating
Density	nom: 1.0 kg/dm ³
Basicity Index	nom: 1.9

Flux Consumption	
Volts	kg Flux / kg Wire DC+
26 V	0.5 kg
30 V	0.6 kg
34 V	0.8 kg
38 V	1.0 kg

Conditions : Dimension 4.0 mm , Amps 580 A , Travel Speed 33 m/h

Classifications	Wire	Weld Metal
Wire	SFA/AWS - EN ISO	AWS - As Welded
OK Autrod 2209	A5.9:ER2209 14343-A:S 22 9 3 N L	-
OK Autrod 2509	A5.9:ER2594 14343-A:S 25 9 4 N L	A5.39: F120A8-ER2594/2594
OK Autrod 308L	A5.9:ER308L 14343-A:S 19 9 L	-
OK Autrod 347	A5.9:ER347 14343-A:S 19 9 Nb	-

Typical Weld Metal Analysis %									
C	Mn	Si	S	P	Ni	Cr	Mo	Cu	N
OK Autrod 2209 Current: DC+, 420A, 27V									
0.01	1.3	0.6	0.01	0.02	8.5	23.0	3.0	0.1	0.14
OK Autrod 2509 Current: DC+, 400A, 28V, 48cm/min									
0.02	0.4	0.45	0.01	0.017	9.3	24.5	3.5	0.10	0.24
OK Autrod 308L DC+									
0.02	1.4	0.5	-	-	9.5	20	0.2	0.1	-
OK Autrod 347 DC+									
0.04	1.0	0.5	-	-	9.6	19.6	-	-	-

Typical Weld Metal Analysis %		
Nb	FN WRC-92	W
OK Autrod 2209 Current: DC+, 420A, 27V		
-	45	-
OK Autrod 2509 Current: DC+, 400A, 28V, 48cm/min		
-	54	<0.002
OK Autrod 308L DC+		
-	11	-

OK Flux 10.94

Typical Weld Metal Analysis %

Nb	FN WRC-92	W
OK Autrod 347 DC+		
0.5	9	-

Typical Mechanical Properties

Wire	Condition	Yield Strength	Tensile Strength	Elongation	Charpy V-Notch
OK Autrod 2209	As Welded DC+	630 MPa	780 MPa	30 %	60 J @ -40 °C 42 J @ -60 °C
OK Autrod 2509	As Welded DC+	680 MPa	870 MPa	25 %	70 J @ 20 °C 50 J @ -60 °C
OK Autrod 308L	As Welded	400 MPa	560 MPa	40 %	85 J @ 20 °C 70 J @ -40 °C 60 J @ -60 °C
OK Autrod 347	As Welded	455 MPa	620 MPa	35 %	100 J @ 20 °C 70 J @ -60 °C 50 J @ -110 °C 30 J @ -196 °C

OK Flux 10.95

Basic, nickel alloying, agglomerated flux for butt welding of stainless steels. Specially recommended for welding of stainless steels when impact strength at low temperatures is required. Low Si addition during welding provides good mechanical properties in the weld metal.

Specifications	
Classifications	EN ISO 14174 : S A AF 2 56 44 Ni DC

Slag Type	Fluoride basic CaF ₂ -Al ₂ O ₃ -SiO ₂
Alloy Transfer	Nickel alloying
Density	nom: 1.0 kg/dm ³
Basicity Index	nom: 2.0

Flux Consumption	
Volts	kg Flux / kg Wire DC+
26 V	0.5 kg
30 V	0.6 kg
34 V	0.8 kg
38 V	1.0 kg

Conditions : Dimension 4.0 mm , Amps 580 A , Travel Speed 33 m/h

Classifications	Wire
Wire	SFA/AWS - EN ISO
OK Autrod 308L	A5.9:ER308L 14343-A:S 19 9 L

Typical Weld Metal Analysis %						
C	Mn	Si	Ni	Cr	N	FN WRC-92
OK Autrod 308L Current: DC+, 420A, 27V						
<0.03	1.4	0.6	11.0	20.0	0.06	5

Typical Mechanical Properties					
Wire	Condition	Yield Strength	Tensile Strength	Elongation	Charpy V-Notch
OK Autrod 308L	As Welded DC+	400 MPa	540 MPa	40 %	80 J @ -60 °C 70 J @ -110 °C 50 J @ -196 °C

OK Flux 10.99

OK Flux 10.99 is a neutral agglomerated basic flux designed for the submerged arc welding process of austenitic stainless steels with relevant wires, either using AC or DC+ current. This flux can also be used in both current modes to weld Ni-based alloys with carefully chosen Ni-based wires. Welding in AC usually provides good mechanical properties and better impact properties (when compared to DC+ current). The high basicity of OK Flux 10.99 gives better impact values, regardless of the current being used. It also has very good weldability in 1G and 2G position; the slag is self-lifting or easily detached leaving clean and nice bead appearance.

Specifications	
Classifications	EN ISO 14174 : S A FB 2 55 53 AC
Slag Type	Fluoride basic CaF ₂ - MgO - Al ₂ O ₃
Alloy Transfer	Non alloying
Density	nom: 1.0 kg/dm ³
Basicity Index	nom: 2.1

Flux Consumption		
Volts	kg Flux / kg Wire DC+	kg Flux / kg Wire AC
26 V	0.7 kg	0.6 kg
30 V	0.8 kg	0.8 kg
34 V	0.9 kg	1.1 kg
38 V	1.1 kg	1.3 kg

Conditions : Dimension 3.2 mm , Amps 400 A , Travel Speed 50 cm/min

Classifications	Wire	Weld Metal
Wire	SFA/AWS - EN ISO	AWS - As Welded
OK Autrod 308L	A5.9:ER308L 14343-A:S 19 9 L	-
OK Autrod 309L	A5.9:ER309L 14343-A:S 23 12 L	-
OK Autrod 316L	A5.9:ER316L 14343-A:S 19 12 3 L	-
OK Autrod 316LMn	A5.9:ER316LMn 14343-A:S 20 16 3 Mn N L	-
OK Autrod NiCrMo-4	A5.14:ERNiCrMo-4 18274-S Ni 6276 (NiCr15Mo16Fe6W4)	A5.39: F100A32-ERNiCrMo-4/NiCrMo-4

Approvals					
Wire	BV	CCS	DNV	LR	
OK Autrod NiCrMo-4	•	•	•	•	

Typical Weld Metal Analysis %									
C	Mn	Si	S	P	Ni	Cr	Mo	V	Cu
OK Autrod 308L AC									
0.025	1.9	0.3	0.01	0.02	9.8	19.2	0.1	-	0.2
OK Autrod 308L DC+									
0.02	1.9	0.3	0.01	0.02	9.8	19.2	0.1	-	0.2
OK Autrod 309L AC									
0.030	1.9	0.4	0.01	0.02	13.0	22.0	0.1	-	0.04
OK Autrod 316L AC									
0.025	1.7	0.4	0.01	0.02	12.0	18.3	2.6	-	0.2
OK Autrod 316LMn									

OK Flux 10.99

Typical Weld Metal Analysis %

C	Mn	Si	S	P	Ni	Cr	Mo	V	Cu
0.03	7.0	0.5	0.01	0.02	16.0	20.0	3.0	-	0.30
OK Autrod NiCrMo-4 AC									
0.015	0.7	0.08	0.002	0.006	Bal	15.2	15.6	0.1	0.1
OK Autrod NiCrMo-4 DC+									
0.01	0.7	0.11	0.002	0.006	Bal	15.2	15.6	0.1	0.1

Typical Weld Metal Analysis %

N	Co	FN WRC-92	W	Fe
OK Autrod 308L AC				
0.07	-	6	-	-
OK Autrod 308L DC+				
0.07	-	6	-	-
OK Autrod 309L AC				
0.09	-	-	-	-
OK Autrod 316L AC				
0.05	-	6	-	-
OK Autrod 316LMn				
0.17	-	-	-	-
OK Autrod NiCrMo-4 AC				
-	0.1	-	3.7	6.5
OK Autrod NiCrMo-4 DC+				
-	0.1	-	3.6	6.5

Typical Mechanical Properties

Wire	Condition	Yield Strength	Tensile Strength	Elongation	Charpy V-Notch
OK Autrod 308L	As Welded AC	400 MPa	560 MPa	36 %	105 J @ -20 °C 100 J @ -40 °C 90 J @ -60 °C 55 J @ -196 °C
OK Autrod 308L	As Welded DC+	400 MPa	560 MPa	36 %	85 J @ -20 °C 80 J @ -40 °C 75 J @ -60 °C 50 J @ -196 °C
OK Autrod 309L	As Welded AC	410 MPa	575 MPa	36 %	105 J @ -20 °C 100 J @ -40 °C 95 J @ -60 °C 85 J @ -110 °C
OK Autrod 316L	As Welded AC	410 MPa	570 MPa	35 %	110 J @ -20 °C 105 J @ -40 °C 100 J @ -60 °C 70 J @ -196 °C
OK Autrod 316LMn	As Welded 400A, 30V, 33m/h AC	420 MPa	630 MPa	40 %	105 J @ -60 °C 90 J @ -110 °C 55 J @ -196 °C
OK Autrod NiCrMo-4	As Welded HI -0,9-1,1 kJ/mm DC+	480 MPa	720 MPa	42 %	75 J @ -196 °C
OK Autrod NiCrMo-4	As Welded HI -0,9-1,1 kJ/mm AC	480 MPa	720 MPa	42 %	100 J @ -196 °C

Exaton 19.9.L (SAW)

Exaton 19.9.L is suitable for joining stainless steels of the 18Cr/8Ni/ELC and 18Cr/8Ni/Nb types for service temperatures up to 350°C (660°F). It is also suitable for welding in cryogenic applications, typically: manufacturing of dewars, containers, tanks, cryostats, and transfer systems for transportation and storage of LNG, LPG, liquid nitrogen and liquid helium. The chemical composition is also optimized for cryogenic applications in terms of impact strength and other characteristics. It has a controlled chemical composition and ferrite content for resistance to microfissuring, and balanced minor additions of certain elements for optimum arc stability, fluidity and low spatter. It is intended for Submerged Arc Welding in combination with Exaton Flux 15W or Exaton Flux 10SW.

Specifications	
Classifications	EN ISO 14343-A : S 19 9 L SFA/AWS A5.9 : ER308L Werkstoffnummer : ~1.4316
Approvals	CE : EN 13479 UKCA : EN 13479 VdTÜV : 03771

Approvals are based on factory location. Please contact ESAB for more information.

Alloy Type	Austenitic (with approx. 8 % ferrite) 19% Cr - 9% Ni - Low C
-------------------	--

Typical Wire Composition %									
C	Mn	Si	S	P	Ni	Cr	Mo	Cu	N
0.019	1.7	0.4	0.012	0.022	10.6	19.8	0.2	0.2	0.06

Typical Wire Composition %				
Nb	Ti	Co	FN deLong	FN WRC-92
0.02	0.004	0.07	6	7

Exaton 19.12.3.L CRYO (SAW)

Exaton 19.12.3.L CRYO is a filler material for joining austenitic stainless steels, e.g. ASTM 316, 316L, as well as 304, 304L, for cryogenic applications and meets the requirements of ASME Section VIII, Division 1, UHA 51 ((a) (4) (-a) (-1)) and others. It is used for service temperatures down to -196°C, and ferritic or martensitic stainless steels, with maximum 19% Cr. The grade has been specifically developed for welding in cryogenic applications, typically: manufacturing of dewars, containers, tanks, cryostats, and transfer systems for transportation and storage of LNG, LPG and liquid nitrogen. The chemical composition is optimized for cryogenic applications in terms of impact strength and other characteristics. It has controlled chemical composition and ferrite content for resistance to microfissuring, and balanced minor additions of certain elements for optimum arc stability and wetting characteristics. Impurity levels are lower in the consumable in order to reduce the risk of hot cracking and to obtain the best arc stability, fluidity, low spatter and wetting properties.

Specifications	
Classifications	EN ISO 14343-A : S (19 12 3 L) SFA/AWS A5.9 : ER316L Werkstoffnummer : ~1.4430 EN ISO 14343-B : SS316L
Approvals	CE : EN 13479 UKCA : EN 13479

Approvals are based on factory location. Please contact ESAB for more information.

Typical Wire Composition %									
C	Mn	Si	S	P	Ni	Cr	Mo	Al	Cu
0.02	1.8	0.4	0.003	0.012	13.3	18.5	2.3	0.01	0.06

Typical Wire Composition %				
N	Nb	Ti	Co	FN WRC-92
0.06	0.01	0.005	0.03	2

Exaton 20.5.3.L

Exaton 20.5.3.L is an austenitic-ferritic stainless-steel wire designed to weld alloys such as UNS S31500 (e.g. Alleima® 3RE60). This grade is recommended for use in chloride-bearing environments where pitting and stress corrosion cracking are potential problems as it delivers superior performance versus standard austenitic stainless steel grades.

Specifications

Classifications	EN ISO 14343-A : S Z 20 5 3 L
------------------------	-------------------------------

Typical Wire Composition %

C	Mn	Si	S	P	Ni	Cr	Mo	Cu	N
0.01	1.33	0.55	0.002	0.015	5.47	20.46	2.67	0.07	0.11

Exaton 20.25.5.LCu (SAW)

Exaton 20.25.5.LCu welding wire is suitable for joining steels of the 20Cr/25Ni/4.5Mo/1.5Cu type - for example Alleima® 2RK65™ used in many areas of the process industry, such as in the production of acetic acid, sulfuric acid, terephthalic or tartaric acid and vinyl chloride. It is also suitable for use in cooling operations involving sea water or heavily polluted river water. It is used for Submerged Arc Welding combined with Exaton Flux 15W.

Specifications

Classifications	EN ISO 14343-A : S 20 25 5 Cu L SFA/AWS A5.9 : ER385 Werkstoffnummer : ~1.4519
Approvals	CE : EN 13479 UKCA : EN 13479

Approvals are based on factory location. Please contact ESAB for more information.

Typical Wire Composition %

C	Mn	Si	S	P	Ni	Cr	Mo	Cu
<=0.020	1.8	0.4	<=0.015	<=0.015	25	20	4.5	1.5

Exaton 22.8.3.L (SAW)

Exaton 22.8.3.L is a duplex stainless filler metal for welding duplex stainless steels. Weldability as well as properties of the all-weld metal is excellent. Corrosion resistance is equal to 904L in most applications. Exaton 22.8.3.L is used for welding of duplex stainless steels such as Alleima SAF 2205 and SAF 2304. It can also be used for welding of duplex stainless steels to carbon steel and for cladding. It is used for Submerged Arc Welding and the recommended flux is Exaton 15W.

Specifications	
Classifications	EN ISO 14343-A : S 22 9 3 N L SFA/AWS A5.9 : ER2209
Approvals	CE : EN 13479 UKCA : EN 13479

Approvals are based on factory location. Please contact ESAB for more information.

Alloy Type	Austenitic-ferritic (22.5 % Cr - 8 % Ni - 3 % Mo - Low C)
------------	---

Typical Wire Composition %									
C	Mn	Si	S	P	Ni	Cr	Mo	V	Cu
0.012	1.5	0.5	0.0007	0.018	8.6	23	3.2	0.05	0.09

Typical Wire Composition %						
N	Nb	Ti	Co	PRE	FN WRC-92	W
0.15	0.01	0.003	0.04	37	55	0.01

Exaton 22.12.HT

Exaton 22.12.HT is an austenitic filler material for welding the high temperature steel grade Alleima 253 MA*, UNS S30815. It is characterized by high creep strength, good resistance to oxidation and good weldability. It is used for Submerged Arc Welding in combination with Exaton Flux 15W. * 253 MA is a trademark owned by Outokumpu OY.

Specifications

Classifications	EN ISO 14343-A : S 21 10 N Werkstoffnummer : 1.4835
Approvals	CE : EN 13479 UKCA : EN 13479

Approvals are based on factory location. Please contact ESAB for more information.

Typical Wire Composition %

C	Mn	Si	S	P	Ni	Cr	Mo	Al	Cu
0.07	0.5	1.6	0.0007	0.020	10.2	21.0	0.1	0.01	0.1

Typical Wire Composition %

N	Nb	Ti	Co	B	FN deLong	Ce
0.17	0.01	0.005	0.05	0.0008	9	0.04

Exaton 24.13.LHF (SAW)

Exaton 24.13.LHF welding wire is particularly suitable for overlay welding and joining dissimilar steels, for example austenitic stainless steels to low alloyed or non alloyed steels. It has excellent resistance to hot cracking due to its enhanced ferrite content. It is used for Submerged Arc Welding and recommended flux is Exaton 15W.

Specifications	
Classifications	EN ISO 14343-A : S 23 12 L SFA/AWS A5.9 : ER309L
Approvals	CE : EN 13479 UKCA : EN 13479 VdTUV : 03771

Approvals are based on factory location. Please contact ESAB for more information.

Typical Wire Composition %									
C	Mn	Si	S	P	Ni	Cr	Mo	V	Cu
0.01	1.8	0.4	0.001	0.011	13.4	23.8	0.04	0.05	0.03

Typical Wire Composition %					
N	Nb	Ti	Co	FN deLong	FN WRC
0.05	0.03	0.004	0.03	14	13

Exaton 24.13.LNb (SAW)

Exaton 24.13.LNb is a niobium-stabilized overalloyed filler metal suitable for overlay welding of carbon and low alloy steels, where a type 347 of overlay is required. It is used for Submerged Arc Welding and recommended flux is Exaton 15W.

Specifications

Classifications	EN ISO 14343-A : S 23 12 Nb SFA/AWS A5.9 : ER309LNb
------------------------	--

Alloy Type	Austenitic (with approx. 15% ferrite) 24% Cr - 13% Ni - Low C - Nb
-------------------	--

Typical Wire Composition %

C	Mn	Si	S	P	Ni	Cr	Mo	Cu	N
0.01	2.1	0.3	0.001	0.013	12.5	24	0.02	0.01	0.05

Typical Wire Composition %

Nb	Ti	Co
0.8	0.005	0.02

Exaton 25.10.4.L (SAW)

Exaton 25.10.4.L welding wire has been specially developed for welding of Alleima SAF 2507 and other super-duplex steels. The grade is characterized by excellent resistance to stress corrosion in chloride-bearing environments and excellent resistance to pitting and crevice corrosion. Exaton 25.10.4.L can also be used for welding Alleima SAF 2205 and corresponding duplex steels when the highest possible corrosion resistance is required. It is used for Submerged Arc Welding and the recommended flux is Exaton 15W.

Specifications	
Classifications	EN ISO 14343-A : S 25 9 4 N L SFA/AWS A5.9 : ER2594
Approvals	CE : EN 13479 UKCA : EN 13479

Approvals are based on factory location. Please contact ESAB for more information.

Typical Wire Composition %									
C	Mn	Si	S	P	Ni	Cr	Mo	V	Cu
0.012	0.4	0.3	0.0005	0.015	9.5	25	4	0.05	0.07

Typical Wire Composition %						
N	Nb	Ti	Co	PRE	FN WRC-92	W
0.25	0.01	0.003	0.04	42	50	0.01

Exaton 25.20.L (SAW)

Exaton 25.20.L is a filler wire for joining Alleima 2RE10 (UNS S31002) and similar grades used in heavily oxidizing media such as pipes in preheaters, coolers and condensers in the chemical industry. It can be used in combination with Exaton 15W.

Specifications

Classifications	EN ISO 14343-A : S Z 25 20 L SFA/AWS A5.9 : ER310 (mod) EN 10088-1 : 1.4335
Approvals	CE : EN 13749 UKCA : EN 13749 VdTÜV : 03771

Approvals are based on factory location. Please contact ESAB for more information.

Typical Wire Composition %

C	Mn	Si	S	P	Ni	Cr	Mo	Cu	Co
<=0.020	1.8	0.2	<=0.015	<=0.020	20	24	<=0.30	<=0.10	<=0.20

Exaton 25.22.2.LMn (SAW)

Exaton 25.22.2.LMn is a manganese alloyed chromium-nickel-molybdenum filler material used for welding UNS S31050, 1.4466 (e.g. Alleima® 2RE69). The weld deposit has excellent low temperature toughness that makes it suitable for joining stainless steels for cryogenic service. Exaton 25.22.2.LMn has extensively been used successfully in all critical high-pressure units of modern urea processes, such as: Stripper tubes - Stamicarbon, Montedison IDR Outerlayer of bimetallic (tripper tubes) - Saipem Ferrules - All processes Carbamate condensers - All processes Decomposers - Montedison Reactor coils - UTI Exaton 25.22.2.LMn has also found extensive use in other corrosive environments in fertilizer plants, such as: - Nitric acid cooler/condensers cooled with polluted cooling water - Heating coils and pipe in NPK plants - Norsk Hydro process It is used for Submerged Arc Welding, for example in combination with Exaton flux 15W.

Specifications

Classifications	EN ISO 14343-A : S 25 22 2 N L SFA/AWS A5.9 : ERG Werkstoffnummer : ~ 1.4466
------------------------	--

Alloy Type	Fully austenitic, 25%Cr - 22%Ni - 2.2%Mo - low C
-------------------	--

Typical Wire Composition %

C	Mn	Si	S	P	Ni	Cr	Mo	Cu	N
<=0.020	4.5	<=0.2	<=0.015	<=0.015	22.0	25.0	2.1	0.05	0.13

Typical Wire Composition %

FN WRC-92
0

Exaton 27.31.4.LCu (SAW)

Exaton 27.31.4.LCu is a copper alloyed chromium-nickel-molybdenum filler material for welding of high-alloy austenitic stainless steels such as Alleima Sanicro® 28 (UNS S08028, 1.4563) type. It is also suitable for joining Alleima Sanicro® 41 (UNS N08825, 2.4858) and other similar materials. Due to its outstanding corrosion properties, Exaton 27.31.4.LCu can be used in the most diverse environments, such as phosphoric and sulphuric acid, sour gas service in the oil & gas industry and chloride bearing seawater. Typical applications are found in heat exchangers, evaporators and transport piping. It is used for Submerged Arc Welding where the recommended flux is Exaton 15W.

Specifications	
Classifications	EN ISO 14343-A : S 27 31 4 Cu L SFA/AWS A5.9 : ER383
Approvals	CE : EN 13479 UKCA : EN 13479

Approvals are based on factory location. Please contact ESAB for more information.

Alloy Type	Austenitic
------------	------------

Typical Wire Composition %									
C	Mn	Si	S	P	Ni	Cr	Mo	Al	Cu
0.01	1.7	0.1	0.001	0.012	31.0	27.0	3.5	0.04	1.0

Typical Wire Composition %		
N	Nb	Co
0.05	0.02	0.03

Exaton 10SW

Exaton 10SW is a chromium-compensating agglomerated flux giving good slag removal and a fine bead appearance. It is suitable for welding with wire and strip electrodes of the chromium & chromium-nickel and chromium-nickel-molybdenum steel types either with or without niobium. Exaton 10SW is an all round flux which can be used for many applications varying from surfacing continuous caster rolls to large components in chemical plants.

Specifications	
Classifications	EN ISO 14174 : S A CS 2 Cr
Welding Current	1200 A (Using 60x0.5 mm strip)
Slag Type	Calcium silicate SiO ₂ -MgO-Al ₂ O ₃ -(CaF ₂)
Density	nom: 1.0 kg/l
Basicity Index	nom: 1.0

Flux Consumption	
Volts	kg Flux / kg Wire DC+
26 V	0.4 kg
30 V	0.55 kg
34 V	0.7 kg
38 V	0.9 kg

Conditions : Dimension 4.0 mm , Amps 580 A , Travel Speed 33 m/h

Classifications	Wire
Wire	SFA/AWS - EN ISO
Exaton 19.12.3.L	A5.9:EQ316L 14343-A:B 19 12 3 L
Exaton 19.13.4.L	A5.9:EQ317L 14343-A:B 19 13 4 L
Exaton 19.9.L	A5.9:EQ308L 14343-A:B 19 9 L
Exaton 19.9.L(SAW)	A5.9:ER308L 14343-A:S 19 9 L
Exaton 19.9.LNb	A5.9:EQ347 14343-A:B 19 9 Nb
Exaton 21.13.3.L	A5.9:EQ(309Lmo) 14343-A:B 21 13 3 L
Exaton 22.8.3.L	A5.9:EQ2209 14343-A:B 22 9 3 N L
Exaton 24.13.L	A5.9:EQ309L 14343-A:B 23 12 L
Exaton 24.13.LNb	A5.9:EQ309LNb 14343-A:B 23 12 Nb

Approvals	
Wire	VdTÜV
Exaton 19.9.L	•
Exaton 19.9.LNb	•
Exaton 22.8.3.L	•

Typical Weld Metal Analysis %									
C	Mn	Si	S	P	Ni	Cr	Mo	Cu	N
Exaton 19.12.3.L (Layer 1 with "24.13.L" & Layer 2 with "19.12.3.L")									

Exaton 10SW

Typical Weld Metal Analysis %

C	Mn	Si	S	P	Ni	Cr	Mo	Cu	N
0.02	0.8	0.7	-	-	11.5	19.0	2.2	-	0.06
Exaton 19.13.4.L Layer 1 with "21.13.3.L"									
<=0.04	-	-	-	-	13	18.5	3.3	-	-
Exaton 19.9.L 1st layer with "24.13.L"									
<=0.03	-	-	-	-	10.0	19.7	-	-	-
Exaton 19.9.LNb (Layer 1 with "24.13.LNb")									
0.02	0.8	0.6	-	-	10.4	21.0	0.0	-	0.05
Exaton 22.8.3.L Layer 1 with "24.13.L" & 2 layers with "22.8.3.L"									
<=0.03	-	-	-	-	8.5	22.7	2.9	-	0.16
Exaton 24.13.L Layer 1 with "24.13.L"									
<=0.07	-	-	-	-	10.5	19.2	-	-	-
Exaton 24.13.LNb									
<=0.06	1.0	0.9	0.01	0.025	9.7	19.2	0.1	0.05	-

Typical Weld Metal Analysis %

Nb	FN WRC-92
Exaton 19.12.3.L (Layer 1 with "24.13.L" & Layer 2 with "19.12.3.L")	
0	-
Exaton 19.13.4.L Layer 1 with "21.13.3.L"	
-	5
Exaton 19.9.L 1st layer with "24.13.L"	
-	8
Exaton 19.9.LNb (Layer 1 with "24.13.LNb")	
0.3	-
Exaton 22.8.3.L Layer 1 with "24.13.L" & 2 layers with "22.8.3.L"	
-	40
Exaton 24.13.L Layer 1 with "24.13.L"	
-	6
Exaton 24.13.LNb	
0.5	6

Typical Mechanical Properties

Wire	Condition	Yield Strength	Tensile Strength	Elongation	Charpy V-Notch
Exaton 19.9.L (SAW)	As Welded	400 MPa	580 MPa	38 %	69 J @ 20 °C 59 J @ -40 °C 40 J @ -196 °C

Exaton 15W

Exaton 15W is a basic welding flux for submerged arc welding giving good slag removal and a fine bead appearance. Its relatively high basicity makes it suitable for joining of austenitic and duplex stainless steel when high impact strength is desired. Due to its low niobium content burn-off it can be used advantageously with stabilized wire electrodes. Exaton 15W is a high performance welding flux in many joining applications in the chemical, petrochemical and oil&gas industry. It is particularly suited for Exaton range of duplex wire electrodes (e.g. 22.8.3.L/25.10.4.L) due to the highly neutral behavior, which ensures an optimal balanced microstructure. Taking the benefit of its features (not limited to nice bead appearance and self slag release only), it can also be used in combination with NiCrMo-3 and NiCrMo-4 wires for several other applications (i.e. both joining and weld overlay).

Specifications	
Classifications	EN ISO 14174 : S A AF 2
Approvals	CE : EN 13479 UKCA : EN 13479

Approvals are based on factory location. Please contact ESAB for more information.

Welding Current	1200 A (Using 60x0.5 mm strip)
Slag Type	Fluoride basic CaF ₂ -Al ₂ O ₃ -SiO ₂
Density	nom: 1.0 Kg/l
Basicity Index	nom: 1.9

Flux Consumption	
Volts	kg Flux / kg Wire DC+
26 V	0.5 kg
30 V	0.6 kg
34 V	0.8 kg
38 V	1.0 kg

Conditions : Dimension 4.0 mm , Amps 580 A , Travel Speed 33 m/h

Classifications	Wire	Weld Metal
Wire	SFA/AWS - EN ISO	AWS - As Welded
Exaton 19.12.3.LCRYO	A5.9:ER316L 14343-A:S (19 12 3 L); 14343-B:SS316L	-
Exaton 19.9.L	A5.9:ER308L 14343-A:S 19 9 L	-
Exaton 20.25.5.LCu	A5.9:ER385 14343-A:S 20 25 5 Cu L	-
Exaton 22.12.HT	14343-A:S 21 10 N	-
Exaton 22.8.3.L	A5.9:ER2209 14343-A:S 22 9 3 N L	A5.39: F115A15-ER2209/2209
Exaton 24.13.LHF	A5.9:ER309L 14343-A:S 23 12 L	-
Exaton 24.13.LNb	A5.9:ER309LNb 14343-A:S 23 12 Nb	-
Exaton 25.10.4.L	A5.9:ER2594 14343-A:S 25 9 4 N L	A5.39: F120A8-ER2594/2594
Exaton 25.22.2.LMn	A5.9:ERG 14343-A:S 25 22 2 N L	-
Exaton 27.31.4.LCu	A5.9:ER383 14343-A:S 27 31 4 Cu L	-
Exaton Ni56	A5.14:ERNiCrMo-4 18274:S Ni 6276 (NiCr15Mo16Fe6W4)	-
Exaton Ni60	A5.14:ERNiCrMo-3 18274:S Ni 6625 (NiCr22Mo9Nb)	-

Exaton 15W

Approvals

Wire	BV	DNV-GL	VdTÜV
Exaton 19.9.L	-	-	•
Exaton 20.25.5.LCu	-	-	•
Exaton 22.8.3.L	•	•	•
Exaton 25.10.4.L	•	•	•

Typical Weld Metal Analysis %

C	Mn	Si	S	P	Ni	Cr	Mo	V	Cu
Exaton 19.12.3.LCRYO									
0.021	1.5	0.5	0.003	0.023	12.8	18	2.3	-	0.07
Exaton 19.9.L									
0.02	1.2	0.6	0.012	0.025	10	19.5	0.15	-	0.1
Exaton 20.25.5.LCu									
0.01	1.4	0.5	-	-	25	19.6	4.5	-	-
Exaton 22.8.3.L Current: DC+, 400A, 28V, 45cm/min									
0.01	1.2	0.01	-	0.02	8.4	22.0	3.0	-	0.12
Exaton 24.13.LNb									
<=0.020	1.2	0.7	<=0.015	<=0.025	12	23.5	-	-	-
Exaton 25.10.4.L Current: DC+, 350A, 28V, 48cm/min									
0.020	0.4	0.5	0.01	0.020	9.0	24.6	3.5	0.05	0.1
Exaton 25.22.2.LMn Current: DC+, 420A, 27V									
0.02	4.0	0.1	-	-	22.0	24.5	2.1	-	0.1
Exaton 27.31.4.LCu									
0.01	1.4	0.4	0.003	0.01	31.3	26.3	3.5	-	1.0
Exaton Ni56 DC+									
0.01	0.4	0.20	-	-	Bal	15.1	15.6	0.1	-
Exaton Ni60 Current: DC+, 400A, 28V, travel speed: 25 m/h.									
0.02	0.2	0.4	0.005	0.015	-	22	9	-	0.1

Typical Weld Metal Analysis %

N	Nb	Ti	Co	PRE	FN WRC-92	W	Fe	Nb+Ta
Exaton 19.12.3.LCRYO								
0.06	-	-	-	-	3	-	-	-
Exaton 19.9.L								
0.05	-	-	0.1	-	6	-	-	-
Exaton 22.8.3.L Current: DC+, 400A, 28V, 45cm/min								
0.14	<0.01	-	-	35	55	-	-	-
Exaton 24.13.LNb								
-	0.7	-	-	-	-	-	-	-
Exaton 25.10.4.L Current: DC+, 350A, 28V, 48cm/min								
0.22	<0.01	<0.001	0.04	42	55	<0.01	-	-
Exaton 25.22.2.LMn Current: DC+, 420A, 27V								
0.12	-	-	-	-	-	-	-	-
Exaton 27.31.4.LCu								
0.06	-	-	-	-	-	-	-	-
Exaton Ni56 DC+								

Exaton 15W

Typical Weld Metal Analysis %

N	Nb	Ti	Co	PRE	FN WRC-92	W	Fe	Nb+Ta
-	-	-	0.1	-	-	3.6	6.8	-
Exaton Ni60 Current: DC+, 400A, 28V, travel speed: 25 m/h.								
-	-	-	-	-	-	-	5	3

Typical Mechanical Properties

Wire	Condition	Yield Strength	Tensile Strength	Elongation	Charpy V-Notch
Exaton 19.12.3.LCRYO	As Welded	415 MPa	560 MPa	34 %	88 J @ -60 °C 70 J @ -110 °C 46 J @ -196 °C
Exaton 19.9.L	As Welded	390 MPa	560 MPa	35 %	90 J @ 20 °C 35 J @ -196 °C
Exaton 20.25.5.LCu	As Welded	345 MPa	550 MPa	40 %	125 J @ 20 °C 100 J @ -196 °C
Exaton 22.12.HT	As Welded	400 MPa	580 MPa	35 %	120 J @ 20 °C
Exaton 22.8.3.L	As Welded	650 MPa	810 MPa	29 %	85 J @ -40 °C 65 J @ -60 °C 29 J @ -110 °C
Exaton 24.13.LHF	As Welded	410 MPa	600 MPa	40 %	140 J @ 20 °C
Exaton 24.13.LNb	As Welded	400 MPa	600 MPa	35 %	90 J @ 20 °C
Exaton 25.10.4.L	As Welded DC+	680 MPa	870 MPa	24 %	70 J @ 20 °C 45 J @ -50 °C 42 J @ -60 °C
Exaton 25.22.2.LMn	As Welded DC+	335 MPa	575 MPa	42 %	120 J @ 20 °C
Exaton 27.31.4.LCu	As Welded	360 MPa	540 MPa	30 %	80 J @ 20 °C 70 J @ -40 °C
Exaton Ni56	As Welded HI 1.6-1.8 kJ/mm DC+	450 MPa	700 MPa	45 %	100 J @ -60 °C 80 J @ -196 °C
Exaton Ni60	As Welded	445 MPa	715 MPa	45 %	93 J @ -60 °C 82 J @ -196 °C

OK Band 308L

OK Band 308L is a stainless welding strip designed for surfacing using the submerged arc welding process. Together with OK Flux 10.05 it produces a 308L type of weld deposit.

Specifications	
Classifications	EN ISO 14343-A : B 19 9 L SFA/AWS A5.9 : EQ308L
Approvals	VdTÜV : 12102

Approvals are based on factory location. Please contact ESAB for more information.

Alloy Type	Austenitic CrNi
-------------------	-----------------

Typical Wire Composition %						
C	Mn	Si	Ni	Cr	N	FN WRC-92
0.015	1.8	0.3	10.5	20.0	0.06	12

OK Band 309L

OK Band 309L is a stainless welding strip designed for surfacing using strip cladding processes. Commonly used as a buffer layer. Often used with OK Flux 10.05 or OK Flux 10.10.

Specifications	
Classifications	EN ISO 14343-A : B 23 12 L SFA/AWS A5.9 : EQ309L
Approvals	VdTÜV : 12102

Approvals are based on factory location. Please contact ESAB for more information.

Alloy Type	Austenitic 24Cr - 13Ni
-------------------	------------------------

Typical Wire Composition %						
C	Mn	Si	Ni	Cr	N	FN WRC-92
0.01	1.71	0.36	13.3	23.72	0.05	15



OK Band 309L ESW

OK Band 309L ESW is a stainless strip for single layer electroslag strip surfacing. Together with OK Flux 10.10 it produces a 308L type of weld deposit.

Specifications

Classifications EN ISO 14343-A : B 22 11 L

Typical Wire Composition %

C	Mn	Si	Ni	Cr	N	FN WRC-92
0.010	1.8	0.2	11.0	21.1	0.05	15

OK Band 309LMo ESW

OK Band 309LMo ESW is a stainless strip for single layer electrosag strip surfacing. Together with OK Flux 10.10 and OK Flux 10.14 it produces a 316L type of weld deposit.

Specifications

Classifications

EN ISO 14343-A : B 21 13 3 L
SFA/AWS A5.9 : EQ309LMo (Mod)

Typical Wire Composition %

C	Mn	Si	Ni	Cr	Mo	N	FN WRC-92
0.015	1.8	0.2	13.5	20.5	2.9	0.06	13

OK Band 309LNb

OK Band 309LNb is a stainless welding strip designed for the submerged arc or electroslag welding process. Together with OK Flux 10.05 it produces a 309LNb type of weld deposit using SAW. In combination with OK Flux 10.14 it manufactures a 347 type of weld deposit using single layer electroslag strip cladding.

Specifications

Classifications	EN ISO 14343-A : B 23 12 L Nb
Approvals	VdTÜV : 12102

Approvals are based on factory location. Please contact ESAB for more information.

Typical Wire Composition %

C	Mn	Si	Ni	Cr	N	Nb	FN WRC-92
0.01	1.98	0.23	12.5	23.83	0.03	0.7	23

OK Band 309LNb ESW

OK Band 309LNb ESW is a stainless strip for single layer electroslag strip surfacing. Together with OK Flux 10.10 it produces a 347 type of weld deposit.

Specifications

Classifications	EN ISO 14343-A : B 22 12 L Nb
------------------------	-------------------------------

Typical Wire Composition %

C	Mn	Si	Ni	Cr	N	Nb	FN WRC-92
0.01	1.74	0.20	11.0	21.14	0.04	0.6	15

OK Band 316L

OK Band 316L is a stainless welding strip designed for surfacing using the submerged arc welding process. Together with OK Flux 10.05 it produces a 316L type of weld deposit. It can also be combined with fluxes designed for electroslag cladding in single and double layer solutions.

Specifications	
Classifications	EN ISO 14343-A : B 19 12 3 L SFA/AWS A5.9 : EQ316L
Approvals	VdTÜV : 12102

Approvals are based on factory location. Please contact ESAB for more information.

Alloy Type	Austenitic CrNiMo
-------------------	-------------------

Typical Wire Composition %							
C	Mn	Si	Ni	Cr	Mo	N	FN WRC-92
0.01	1.73	0.4	12.6	18.5	2.9	0.05	7

OK Band 347

OK Band 347 is a stainless welding strip designed for surfacing using strip cladding processes. Together with OK Flux 10.05 or OK Flux 10.10 it produces a 347 type weld deposit.

Specifications	
Classifications	EN ISO 14343-A : B 19 9 Nb SFA/AWS A5.9 : EQ347
Approvals	VdTÜV : 12102

Approvals are based on factory location. Please contact ESAB for more information.

Alloy Type	Austenitic CrNiNb
-------------------	-------------------

Typical Wire Composition %							
C	Mn	Si	Ni	Cr	N	Nb	FN WRC-92
0.02	1.8	0.37	10.0	19.5	0.06	0.5	11

OK Flux 10.05

An agglomerated flux designed for strip cladding on unalloyed or low alloyed steels with high-alloyed Cr or Cr-Ni strips. OK Flux 10.05 is designed for the SAW process delivering good welding characteristics, fine bead appearance and easy slag removal.

Specifications	
Classifications	EN ISO 14174 : S A AAS 2B 56 34 DC

Welding Current	1000 A (60 x 0.5 mm strip)
Slag Type	Acid-aluminium-silicate Al ₂ O ₃ -SiO ₂ -CaF ₂ -MgO
Alloy Transfer	Non alloying
Density	nom: 0.7 kg/dm ³
Basicity Index	nom: 1.1

Flux Consumption	
Volts	kg Flux / kg Wire DC+
25 V	0.4 kg
28 V	0.5 kg
32 V	0.6 kg

Conditions : Dimension 60 x 0.5 mm , Amps 750 A , Travel Speed 7 m/h

Classifications	Wire
Wire	SFA/AWS - EN ISO
OK Band 308L	A5.9:EQ308L 14343-A:B 19 9 L
OK Band 309LNb	14343-A:B 23 12 L Nb
OK Band 316L	A5.9:EQ316L 14343-A:B 19 12 3 L
OK Band 347	A5.9:EQ347 14343-A:B 19 9 Nb

Approvals	
Wire	VdTÜV
OK Band 316L	•

Typical Weld Metal Analysis %									
C	Mn	Si	S	P	Ni	Cr	Mo	Cu	N
OK Band 308L									
0.02	1.0	0.6	0.01	0.02	10.5	19.0	0.1	0.03	0.03
OK Band 309LNb									
0.03	1.1	0.6	0.01	0.02	10.0	19.0	0.2	0.1	0.04
OK Band 316L									
0.02	1.1	0.7	0.01	0.02	13.0	18	2.5	0.3	0.02
OK Band 347									
0.02	1.1	0.7	0.005	0.02	10.5	19.0	0.1	0.05	0.03

Typical Weld Metal Analysis %	
Nb	FN WRC-92
OK Band 308L	
0.01	6



OK Flux 10.05

Typical Weld Metal Analysis %	
Nb	FN WRC-92
OK Band 309LNb	
0.35	5
OK Band 316L	
0.05	7
OK Band 347	
0.35	8

OK Flux 10.10

High basic, all mineral, agglomerated flux designed for electro slag strip surfacing. The flux is particularly suitable for strip cladding with stainless strip of the Cr-, Cr-Ni- and Cr-Ni-Mo-steel types, with or without Nb.

Specifications	
Classifications	EN ISO 14174 : ES A FB 2B 56 44 DC

Welding Current	1700 A (60 x 0.5 mm strip)
Slag Type	Fluoride basic CaF ₂ -Al ₂ O ₃
Alloy Transfer	Moderately silicon alloying
Density	nom: 1.0 kg/dm ³
Basicity Index	nom: 4.0

Flux Consumption	
Volts	kg Flux / kg Wire DC+
25 V	0.5 kg

Conditions : Dimension , Amps 1250 A , Travel Speed 9 m/h

Classifications	Wire	Weld Metal
Wire	SFA/AWS - EN ISO	AWS - As Welded
OK Band 309L ESW	14343-A:B 22 11 L	A5.39: ESCLAD1-EQ309L(Mod)/308L
OK Band 309L Mo	A5.9:EQ309L Mo (Mod) 14343-A:B 21 13 3 L	A5.39: ESCLAD1-EQ309L Mo(mod)/316L
OK Band 309L Nb ESW	14343-A:B 22 12 L Nb	A5.39: ESCLAD1-EQ309L(mod)/347
OK Band 430	14343-A:B 17	A5.39: ESCLAD2-EQ430(mod)/430

Approvals	
Wire	VdTÜV
OK Band 309L Nb ESW	•

Typical Weld Metal Analysis %									
C	Mn	Si	S	P	Ni	Cr	Mo	Cu	N
OK Band 309L ESW 1st layer									
0.03	1.2	0.4	0.001	0.002	10.0	19.0	0.2	0.1	0.05
OK Band 309L ESW 2nd layer									
0.02	1.2	0.5	0.001	0.002	11.0	20.0	0.2	0.1	0.05
OK Band 309L Mo 1st layer									
0.02	1.1	0.4	0.001	0.008	12.5	18.0	2.8	0.1	0.04
OK Band 309L Mo 2nd layer									
0.02	1.3	0.5	0.001	0.008	13.0	19.0	3.0	0.1	0.04
OK Band 309L Nb ESW 1st layer									
0.03	1.3	0.5	0.001	0.01	10.0	19.0	0.1	0.1	0.05
0.02	1.2	0.4	-	-	10.0	18.5	0.2	-	0.04
OK Band 309L Nb ESW 2nd layer									
0.02	1.3	0.5	-	-	11.0	20.5	0.1	-	0.05
OK Band 430 1st layer									
0.06	0.3	0.6	0.005	0.03	0.2	13.3	0.1	0.2	-
OK Band 430 2nd layer									
0.05	0.3	0.6	0.005	0.03	0.2	15.2	0.1	0.2	-

OK Flux 10.10

Typical Weld Metal Analysis %		
Nb	FN WRC-92	O
OK Band 309L ESW 1st layer		
-	4	0.02
OK Band 309L ESW 2nd layer		
-	7	0.02
OK Band 309L Mo 1st layer		
-	6	-
OK Band 309L Mo 2nd layer		
-	8	-
OK Band 309L Nb ESW 1st layer		
0.4	4	-
0.5	7	-
OK Band 309L Nb ESW 2nd layer		
0.4	9	-

OK Flux 10.14

High basic agglomerated flux for electro slag strip cladding. The flux is suitable for cladding with austenitic Cr-, CrNi- and CrNiMo-strips at higher travel speeds.

Specifications	
Classifications	EN ISO 14174 : ES A FB 2B 56 44 DC
Welding Current	approx. 2500 A
Slag Type	Fluoride basic CaF ₂ -Al ₂ O ₃
Alloy Transfer	Moderately silicon alloying
Density	nom: 1.0 kg/dm ³
Basicity Index	nom: 4.4

Classifications	Wire	Weld Metal
Wire	SFA/AWS - EN ISO	AWS - As Welded
OK Band 309LMo ESW	A5.9:EQ309LMo (Mod) 14343-A:B 21 13 3 L	A5.39: ESCLAD1-EQ309LMo (Mod)/316L)
OK Band 309LNb	14343-A:B 23 12 L Nb	-

Approvals	
Wire	
*Selected production units only. Please contact ESAB for more information. Visit esab.com to download specific flux/wire combination fact sheets for more details.	

Typical Weld Metal Analysis %									
C	Mn	Si	S	P	Ni	Cr	Mo	Cu	N
OK Band 309LMo ESW 1 layer									
0.030	1.38	0.37	0.003	0.017	11.7	17.4	2.43	0.08	0.03
0.027	1.38	0.38	0.003	0.018	12.1	18.0	2.52	0.08	0.03
OK Band 309LNb 1 layer									
0.04	1.6	0.5	0.01	0.01	10.0	19.0	0.02	-	0.02
0.04	1.7	0.4	0.01	0.01	11.0	20.0	0.1	-	0.02

Typical Weld Metal Analysis %	
FN WRC-92	
OK Band 309LMo ESW 1 layer	
4	
6	
OK Band 309LNb 1 layer	
5	
9	

OK Flux 10.26

OK Flux 10.26 is a high basic, agglomerated Ni-, Cr- and Mo-adding flux designed for single layer electroslag strip cladding solution. The flux has very good welding characteristics gives a smooth bead appearance and easy slag removal. It can be used to achieve 316L and 317L weld deposit chemistry in combination with equivalent strip grades.

Specifications	
Classifications	EN ISO 14174 : ES A FB 2B 54 91 NiMo DC
Slag Type	Fluoride basic
Alloy Transfer	Nickel, chromium and molybdenum
Density	nom: 1.2 kg/dm ³
Basicity Index	nom: 3.0

Classifications	Wire
Wire	SFA/AWS - EN ISO
19.13.4.L ESW	A5.9:EQ317L 14343-A:B 19 13 4 L
OK Band 316L	A5.9:EQ316L 14343-A:B 19 12 3 L

Typical Weld Metal Analysis %									
C	Mn	Si	S	P	Ni	Cr	Mo	Cu	N
19.13.4.L ESW DC+, 1250A, 24V, 18cm/min									
0.02	1.0	0.5	0.01	0.02	13.8	19	3.4	0.07	-
OK Band 316L DC+, 1200A, 24V, 16-18 cm/min									
0.02	1.2	0.2	0.01	0.02	12.8	19.0	2.7	0.1	0.05

Typical Weld Metal Analysis %									
FN WRC-92									
19.13.4.L ESW DC+, 1250A, 24V, 18cm/min									
7									
OK Band 316L DC+, 1200A, 24V, 16-18 cm/min									
7									

Exaton 19.9.L (ESW)

Exaton 19.9.L is a chromium-nickel strip electrode used for electro-slag welding (ESW) or submerged arc welding (SAW) to deposit a second layer corrosion resistant alloy of 18%Cr/8%Ni composition on carbon- and low alloyed steels. The buffer layer is deposited using an over-alloyed consumable, such as 22.11.L or 24.13.L. Recommended fluxes are Exaton 10SW, 47S and 49S.

Specifications

Classifications	EN ISO 14343-A : B 19 9 L SFA/AWS A5.9 : EQ308L
Approvals	CE : EN 13479 UKCA : EN 13479

Approvals are based on factory location. Please contact ESAB for more information.

Alloy Type	Austenitic (with approx. 8 % ferrite) 19% Cr - 9% Ni - Low C
-------------------	--

Typical Wire Composition %

C	Mn	Si	S	P	Ni	Cr	Mo	Cu	FN WRC-92
<=0.015	1.8	0.35	<=0.015	<=0.015	10	20	<=0.3	<=0.1	12

Exaton 19.9.LNb

Exaton 19.9.LNb is a niobium stabilized chromium-nickel strip electrode used for electro-slag welding (ESW) or submerged arc welding (SAW) to deposit a second layer corrosion resistant alloy of stabilized 19%Cr/9%Ni composition on carbon- and low alloyed steels. The buffer layer is deposited using an over-alloyed consumable, such as 21.11.LNb or 24.13.LNb. Recommended fluxes for ESW are Exaton 47S and Exaton 49S, whilst Exaton 10SW for SAW.

Specifications

Classifications	EN ISO 14343-A : B 19 9 Nb SFA/AWS A5.9 : EQ347
------------------------	--

Typical Wire Composition %

C	Mn	Si	S	P	Ni	Cr	Mo	Cu	N
<=0.02	1.8	0.4	<=0.02	<=0.02	10.5	20	<=0.3	<=0.3	-

Typical Wire Composition %

Nb	FN WRC-92
0.5	11

Exaton 19.12.3.L (ESW)

Exaton 19.12.3.L is a chromium-nickel-molybdenum strip electrode used for electro-slag welding (ESW) or submerged arc welding (SAW) to deposit a second layer corrosion resistant alloy of 19%Cr/12%Ni/3%Mo composition on carbon- and low alloyed steels. The buffer layer is deposited using an over-alloyed consumable, such as 21.13.3.L, 22.11.1.L or 24.13.L. Recommended fluxes for ESW are Exaton 47S and Exaton 49S, whilst Exaton 10SW for SAW. Exaton 19.12.3.L is also suitable for a single layer solution in combination with OK Flux 10.26.

Specifications

Classifications	EN ISO 14343-A : B 19 12 3 L SFA/AWS A5.9 : EQ316L
Approvals	CE : EN 13479 UKCA : EN 13479

Approvals are based on factory location. Please contact ESAB for more information.

Typical Wire Composition %

C	Mn	Si	S	P	Ni	Cr	Mo	Cu	FN WRC-92
<=0.020	1.8	0.4	<=0.020	<=0.020	13	18.5	2.9	<=0.3	8

Exaton 19.13.4.L (ESW)

Exaton 19.13.4.L is a chromium-nickel-molybdenum strip electrode used for electro-slag welding (ESW) or submerged arc welding (SAW) to deposit a second layer corrosion resistant alloy of 19%Cr/13%Ni/4%Mo composition on carbon- and low alloyed steels. The buffer layer is deposited using an over-alloyed consumable, such as 21.13.3.L, 22.11.L or 24.13.L. Exaton 19.13.4.L is also suitable for a single layer solution in combination with OK Flux 10.26.

Specifications

Classifications

EN ISO 14343-A : B 19 13 4 L
SFA/AWS A5.9 : EQ317L

Typical Wire Composition %

C	Mn	Si	S	P	Ni	Cr	Mo	Cu	FN WRC-92
<=0.02	1.5	0.4	<=0.020	<=0.020	14	19	3.6	<=0.3	7

Exaton 20.25.5.LCu (ESW)

Exaton 20.25.5.LCu is a copper alloyed chromium-nickel-molybdenum strip electrode used for electro-slag welding (ESW) or submerged arc welding (SAW) to deposit a second and third layer corrosion resistant alloy of 20%Cr/25%Ni/5%Mo/Cu composition on carbon- and low alloyed steels. The buffer layer can be deposited using Exaton 20.25.5.LCu, but also strip electrodes such as 21.13.3.L or 22.11.L can be used. Exaton 20.25.5.LCu is used for weld surfacing of components in the chemical, petrochemical, marine industry where corrosion resistance equal to UNS N08904 is required. Typical components are heat exchangers, pressure vessels, shafts etc.

Specifications

Classifications	EN ISO 14343 : B 20 25 5 Cu L SFA/AWS A5.9 : EQ385
------------------------	---

Typical Wire Composition %

C	Mn	Si	S	P	Ni	Cr	Mo	Cu
<=0.020	1.8	0.4	<=0.015	<=0.015	25	20	4.5	1.5

Exaton 21.11.LNb

Exaton 21.11.LNb is a niobium stabilized chromium-nickel strip electrode used for electro-slag welding (ESW) to deposit a single layer overlay of stabilized corrosion resistant alloy of 19%Cr/9%Ni composition on carbon and low alloyed steels. It can also be combined with 19.9.LNb for surfacing of two layer overlays. Recommended fluxes are Exaton 47S and Exaton 49S.

Specifications	
Classifications	EN ISO 14343-A : B 22 11 L Nb SFA/AWS A5.9 : EQ ³ 309LNb*

Typical Wire Composition %									
C	Mn	Si	S	P	Ni	Cr	Mo	Cu	N
<=0.015	1.8	0.2	<=0.020	<=0.020	11	21	<=0.3	<=0.3	-

Typical Wire Composition %	
Nb	FN WRC-92
0.55	14

Exaton 21.13.3.L

Exaton 21.13.3.L is a chromium-nickel-molybdenum strip electrode used for corrosion resistant alloy surfacing with electro-slag welding (ESW) or with submerged arc welding (SAW). In ESW with Exaton 47S flux, single layer overlays on carbon- and low alloyed steels of 316/316L composition can be deposited. In SAW with Exaton 10SW flux, buffer layers of 18%Cr/8%Ni/2%Mo composition can be deposited on carbon- and low alloyed steels before surfacing of second layers with molybdenum containing alloys. – Combined with 19.13.4.L for the second layer it will give 317L weld deposit – Combined with 20.25.5.LCu for the second layer it will give 385 weld deposit – Other combinations and conditions are possible.

Specifications	
Classifications	EN ISO 14343-A : B 21 13 3 L SFA/AWS A5.9 : EQ(309LMo)

Typical Wire Composition %									
C	Mn	Si	S	P	Ni	Cr	Mo	Cu	FN WRC-92
<=0.015	1.8	0.2	<=0.015	<=0.020	13.5	20.5	2.9	<=0.3	13

Exaton 22.8.3.L (ESW)

Exaton 22.8.3.L is a strip electrodes used to obtain a 2209 (SAF™ 2205) corrosion resistant overlay weld deposit on carbon, carbon-manganese and low-alloy steels using submerged-arc welding (SAW) with 10SW flux or electroslag welding (ESW) with 47S flux. Other combinations and conditions are possible.

Specifications	
Classifications	EN ISO 14343-A : B 22 9 3 N L SFA/AWS A5.9 : EQ2209
Approvals	CE : EN 13479 UKCA : EN 13479

Approvals are based on factory location. Please contact ESAB for more information.

Typical Wire Composition %									
C	Mn	Si	S	P	Ni	Cr	Mo	N	FN WRC-92
<=0.020	1.6	0.5	<=0.015	<=0.020	9	23	3.1	0.15	50

Exaton 22.11.L

Exaton 22.11.L is a chromium-nickel strip electrode used for electro-slag welding (ESW) to deposit a single layer overlay of corrosion resistant alloy of 19%Cr/9%Ni composition on carbon- and low alloyed steels. It can also be combined with 19.9.L for surfacing of two layer overlays.

Specifications

Classifications	EN ISO 14343-A : B 22 11 L SFA/AWS A5.9 : EQ(309L)
------------------------	---

Typical Wire Composition %

C	Mn	Si	S	P	Ni	Cr	Mo	Cu	FN WRC-92
<=0.015	1.8	0.2	<=0.020	<=0.020	11.5	21	<=0.3	<=0.1	13

Exaton 24.13.L (ESW)

Exaton 24.13.L is a chromium-nickel strip electrode used for submerged arc welding (SAW) and high speed electro-slag welding (ESW) to deposit a buffer overlay of corrosion resistant alloy of 19%Cr/9%Ni composition on carbon- and low alloyed steels. It is combined with Exaton 19.9.L for surfacing of two layer overlays.

Specifications	
Classifications	EN ISO 14343-A : B 23 12 L SFA/AWS A5.9 : EQ309L
Approvals	CE : EN 13479 UKCA : EN 13479

Approvals are based on factory location. Please contact ESAB for more information.

Typical Wire Composition %									
C	Mn	Si	S	P	Ni	Cr	Mo	Cu	FN WRC-92
<=0.015	1.8	0.35	<=0.015	<=0.015	13	23.5	<=0.3	<=0.1	15

Exaton 24.13.LNb (ESW)

Exaton 24.13.LNb is a niobium stabilized chromium-nickel strip electrode used for submerged arc welding (SAW) to deposit a buffer layer of stabilized corrosion resistant alloy of 19%Cr/9%Ni composition on carbon and low alloyed steels. In high speed electro-slag welding (ESW) it can be used for single layer deposits of 347 composition on carbon- and low alloyed steels. It can also be combined with 19.9.LNb for surfacing of two layer overlays. Recommended fluxes for ESW are Exaton 47S and Exaton 49S, whilst Exaton 10SW for SAW.

Specifications

Classifications	EN ISO 14343-A : B 23 12 Nb SFA/AWS A5.9 : EQ"309LNb"
------------------------	--

Typical Wire Composition %

C	Mn	Si	S	P	Ni	Cr	Mo	Cu	Nb
<=0.02	2	0.3	<=0.020	<=0.020	12.5	24	<=0.3	<=0.3	0.75

Typical Wire Composition %

FN WRC-92
22

Exaton 25.22.2.LMn (ESW)

Exaton 25.22.2.LMn is a chromium-nickel-molybdenum strip electrode used for electro-slag welding (ESW) or submerged arc welding (SAW) to deposit a second layer corrosion resistant alloy of 25%Cr/22%Ni/2%Mo composition on carbon- and low alloyed steels. It can also be used as buffer layer before depositing second layers. Exaton 25.22.2.LMn is used for corrosion resistant weld surfacing of components in urea plants. Typical components are pressure vessels, heat exchangers and over-head condensers.

Specifications

Classifications	EN ISO 14343-A : B 25 22 2 N L SFA/AWS A5.9 : EQG
------------------------	--

Alloy Type	Fully austenitic, 25%Cr - 22%Ni - 2.2%Mo - low C
-------------------	--

Typical Wire Composition %

C	Mn	Si	S	P	Ni	Cr	Mo	N
<=0.020	4.5	<=0.2	<=0.015	<=0.015	22.0	25.0	2.1	0.13

Exaton 29.8.2.L (ESW)

Exaton 29.8.2.L is a super-duplex strip designed for cladding application. Taking the benefit of its high chromium content, the weld deposit of Exaton 29.8.2.L has very good resistance in several high corrosive environments.

Specifications

Classifications EN ISO 14343-A : B Z 29 8 2 L

Alloy Type Austenitic-ferritic (duplex) with approx. 50 FN - 29% Cr - 7% Ni - 2% Mo - Low C

Typical Wire Composition %

C	Mn	Si	S	P	Ni	Cr	Mo	Cu	N
<0.025	1	0.4	0.0005	0.015	7	29	2.2	0.11	0.3

Typical Wire Composition %

Nb	Ti	Co	PRE
0.01	0.003	0.07	41.7

Exaton 10SW

Exaton 10SW is a chromium-compensating agglomerated flux giving good slag removal and a fine bead appearance. It is suitable for welding with wire and strip electrodes of the chromium & chromium-nickel and chromium-nickel-molybdenum steel types either with or without niobium. Exaton 10SW is an all round flux which can be used for many applications varying from surfacing continuous caster rolls to large components in chemical plants.

Specifications	
Classifications	EN ISO 14174 : S A CS 2 Cr
Welding Current	1200 A (Using 60x0.5 mm strip)
Slag Type	Calcium silicate SiO ₂ -MgO-Al ₂ O ₃ -(CaF ₂)
Density	nom: 1.0 kg/l
Basicity Index	nom: 1.0

Flux Consumption	
Volts	kg Flux / kg Wire DC+
26 V	0.4 kg
30 V	0.55 kg
34 V	0.7 kg
38 V	0.9 kg

Conditions : Dimension 4.0 mm , Amps 580 A , Travel Speed 33 m/h

Classifications	Wire
Wire	SFA/AWS - EN ISO
Exaton 19.12.3.L	A5.9:EQ316L 14343-A:B 19 12 3 L
Exaton 19.13.4.L	A5.9:EQ317L 14343-A:B 19 13 4 L
Exaton 19.9.L	A5.9:EQ308L 14343-A:B 19 9 L
Exaton 19.9.L(SAW)	A5.9:ER308L 14343-A:S 19 9 L
Exaton 19.9.LNb	A5.9:EQ347 14343-A:B 19 9 Nb
Exaton 21.13.3.L	A5.9:EQ(309LMo) 14343-A:B 21 13 3 L
Exaton 22.8.3.L	A5.9:EQ2209 14343-A:B 22 9 3 N L
Exaton 24.13.L	A5.9:EQ309L 14343-A:B 23 12 L
Exaton 24.13.LNb	A5.9:EQ309LNb 14343-A:B 23 12 Nb

Approvals	
Wire	VdTÜV
Exaton 19.9.L	•
Exaton 19.9.LNb	•
Exaton 22.8.3.L	•

Typical Weld Metal Analysis %									
C	Mn	Si	S	P	Ni	Cr	Mo	Cu	N
Exaton 19.12.3.L (Layer 1 with "24.13.L" & Layer 2 with "19.12.3.L")									

Exaton 10SW

Typical Weld Metal Analysis %									
C	Mn	Si	S	P	Ni	Cr	Mo	Cu	N
0.02	0.8	0.7	-	-	11.5	19.0	2.2	-	0.06
Exaton 19.13.4.L Layer 1 with "21.13.3.L"									
<=0.04	-	-	-	-	13	18.5	3.3	-	-
Exaton 19.9.L 1st layer with "24.13.L"									
<=0.03	-	-	-	-	10.0	19.7	-	-	-
Exaton 19.9.LNb (Layer 1 with "24.13.LNb")									
0.02	0.8	0.6	-	-	10.4	21.0	0.0	-	0.05
Exaton 22.8.3.L Layer 1 with "24.13.L" & 2 layers with "22.8.3.L"									
<=0.03	-	-	-	-	8.5	22.7	2.9	-	0.16
Exaton 24.13.L Layer 1 with "24.13.L"									
<=0.07	-	-	-	-	10.5	19.2	-	-	-
Exaton 24.13.LNb									
<=0.06	1.0	0.9	0.01	0.025	9.7	19.2	0.1	0.05	-

Typical Weld Metal Analysis %	
Nb	FN WRC-92
Exaton 19.12.3.L (Layer 1 with "24.13.L" & Layer 2 with "19.12.3.L")	
0	-
Exaton 19.13.4.L Layer 1 with "21.13.3.L"	
-	5
Exaton 19.9.L 1st layer with "24.13.L"	
-	8
Exaton 19.9.LNb (Layer 1 with "24.13.LNb")	
0.3	-
Exaton 22.8.3.L Layer 1 with "24.13.L" & 2 layers with "22.8.3.L"	
-	40
Exaton 24.13.L Layer 1 with "24.13.L"	
-	6
Exaton 24.13.LNb	
0.5	6

Typical Mechanical Properties					
Wire	Condition	Yield Strength	Tensile Strength	Elongation	Charpy V-Notch
Exaton 19.9.L (SAW)	As Welded	400 MPa	580 MPa	38 %	69 J @ 20 °C 59 J @ -40 °C 40 J @ -196 °C

Exaton 31S

31S is a neutral welding flux for submerged arc welding giving good slag removal and fine bead appearance. It is suitable for surfacing with strip and wire electrodes and can also be used for joining. 31S is intended primarily for welding with strip or wire electrodes of the 310LMo type such as 25.22.2.LMn for urea applications.

Specifications	
Classifications	EN ISO 14174 : S A AB 2
Welding Current	1200
Density	nom: 0.9 Kg/l
Basicity Index	nom: 1.0

Classifications	Wire
Wire	SFA/AWS - EN ISO
Exaton 25.22.2.LMn	A5.9:EQG 14343-A:B 25 22 2 N L
Exaton 25.22.2.LMn	A5.9:ERG 14343-A:S 25 22 2 N L

Typical Weld Metal Analysis %								
C	Mn	Si	S	P	Ni	Cr	Mo	N
Exaton 25.22.2.LMn								
0.02	3.8	0.6	-	-	22	24.5	2	0.12
Exaton 25.22.2.LMn (2 layers)								
0.02	3.6	0.6	-	-	22	24.2	2.0	0.13

Typical Mechanical Properties					
Wire	Condition	Yield Strength	Tensile Strength	Elongation	Charpy V-Notch
Exaton 25.22.2.LMn	As Welded	320 MPa	560 MPa	50 %	125 J @ 20 °C 115 J @ -40 °C 65 J @ -196 °C
Exaton 25.22.2.LMn	As Welded	380 MPa	570 MPa	40 %	75 J @ 20 °C 40 J @ -196 °C

Exaton 37S

Exaton 37S is a highly basic welding flux for electroslag strip surfacing. It gives excellent slag removal and bead appearance also for niobium-alloyed strip electrodes. Flux Exaton 37S is used together with strip electrodes of chromium, chromium-nickel and chromium-nickel-molybdenum steel types with or without niobium.

Specifications	
Classifications	EN ISO 14174 : ES A FB 2B
Welding Current	1800 A (Using 60x0.5 mm strip)
Slag Type	Fluoride basic CaF ₂ -Al ₂ O ₃
Density	nom: 0.8 Kg/l
Basicity Index	nom: 3.8

Flux Consumption	
Volts	kg Flux / kg Wire DC+
25 V	0.5 kg

Conditions : Dimension , Amps 1250 A , Travel Speed 9 m/h

Classifications	Wire
Wire	SFA/AWS - EN ISO
Exaton 25.22.2.LMn	A5.9:EQG 14343-A:B 25 22 2 N L

Typical Weld Metal Analysis %								
C	Mn	Si	S	P	Ni	Cr	Mo	N
Exaton 25.22.2.LMn (2 layers)								
0.02	3.4	0.5	-	-	21.8	24.2	2.1	0.12

Exaton 47S

Exaton 47S is a highly basic welding flux for electroslag strip surfacing. It gives excellent slag removal and bead appearance also for niobium-alloyed strip electrodes. Flux Exaton 47S is used together with strip electrodes of steel types chromium, chromium-nickel and chromium-nickel-molybdenum with or without niobium. The high basicity of flux Exaton 47S makes it especially suitable for duplex, super-duplex and fully austenitic stainless steel surfacings.

Specifications	
Classifications	EN ISO 14174 : ES A FB 2B
Welding Current	1700 A (Using 60x0.5 strip)
Slag Type	Fluoride basic CaF ₂ -Al ₂ O ₃
Density	nom: 1.0 Kg/l
Basicity Index	nom: 4.0

Flux Consumption	
Volts	kg Flux / kg Wire DC+
25 V	0,5 kg

Conditions : Dimension , Amps 1250 A , Travel Speed 9 m/h

Classifications	Wire	Weld Metal
Wire	SFA/AWS - EN ISO	AWS - As Welded
Exaton 19.12.3.L	A5.9:EQ316L 14343-A:B 19 12 3 L	-
Exaton 19.13.4.L	A5.9:EQ317L 14343-A:B 19 13 4 L	-
Exaton 19.9.L	A5.9:EQ308L 14343-A:B 19 9 L	-
Exaton 19.9.LNb	A5.9:EQ347 14343-A:B 19 9 Nb	-
Exaton 21.11.LNb	A5.9:EQ"309LNb" 14343-A:B 22 11 L Nb	A5.39: ESCLAD1-EQ"309LNb"/347
Exaton 21.13.3.L	A5.9:EQ(309LMo) 14343-A:B 21 13 3 L	-
Exaton 22.11.L	A5.9:EQ(309L) 14343-A:B 22 11 L	A5.39: ESCLAD1-EQ309L(Mod)/308L
Exaton 22.8.3.L	A5.9:EQ2209 14343-A:B 22 9 3 N L	-
Exaton 24.13.L	A5.9:EQ309L 14343-A:B 23 12 L	-
Exaton 24.13.LNb	A5.9:EQ"309LNb" 14343-A:B 23 12 Nb	-
Exaton 25.22.2.LMn	A5.9:EQG 14343-A:B 25 22 2 N L	-

Typical Weld Metal Analysis %									
C	Mn	Si	S	P	Ni	Cr	Mo	Cu	N
Exaton 19.12.3.L 1st layer with "22.11.L"									
<=0.03	-	-	-	-	12	18.2	2.3	-	-
Exaton 19.13.4.L 1st layer with "21.13.3.L"									
<=0.03	-	-	-	-	13.2	18.5	3.4	-	-
Exaton 19.13.4.L 1st layer with "22.11.L"									
<=0.03	-	-	-	-	13	18.5	3.2	-	-

Exaton 47S

Typical Weld Metal Analysis %									
C	Mn	Si	S	P	Ni	Cr	Mo	Cu	N
Exaton 19.9.L 1st layer with "22.11.L"									
<=0.030	-	-	-	-	10	19.5	-	-	-
Exaton 19.9.LNb (Layer 1 with "21.11.L" & Layer 2 with "19.9.LNb")									
0.01	1.2	0.4	0.009	0.014	10.5	19.2	0.1	0.06	0.03
Exaton 21.11.LNb (1-layer)									
0.02	1.3	0.5	0.001	0.01	10.1	19.3	0.1	0.03	0.05
Exaton 21.13.3.L (1 layer)									
0.02	1.1	0.4	0.002	0.013	12.5	18.7	2.7	0.06	0.03
Exaton 22.11.L									
<=0.06	-	-	-	-	9.7	18.5	-	-	-
Exaton 22.8.3.L Layer 1 with "22.11.L" & 2 layers with "22.8.3.L"									
<=0.02	-	-	-	-	8.5	22.5	3.0	-	0.15
Exaton 22.8.3.L Layer 1 with "22.8.3.L" & 2 layers with "22.8.3.L"									
<=0.02	-	-	-	-	8.5	22.5	3.1	-	0.16
Exaton 24.13.L									
0.03	1.4	0.54	0.003	0.015	10.9	19.0	0.10	0.03	0.04
Exaton 24.13.LNb (1 layer)									
0.03	1.5	0.4	0.002	0.011	10.7	20.8	0.2	0.04	0.04
Exaton 25.22.2.LMn (2 layers)									
0.02	3.5	0.4	0.002	0.016	22.0	24.6	2.0	-	0.14

Typical Weld Metal Analysis %		
Nb	FN WRC-92	Nb+Ta
Exaton 19.12.3.L 1st layer with "22.11.L"		
-	6	-
Exaton 19.13.4.L 1st layer with "21.13.3.L"		
-	6	-
Exaton 19.13.4.L 1st layer with "22.11.L"		
-	6	-
Exaton 19.9.L 1st layer with "22.11.L"		
-	8	-
Exaton 19.9.LNb (Layer 1 with "21.11.L" & Layer 2 with "19.9.LNb")		
-	8	0.3
Exaton 21.11.LNb (1-layer)		
0.4	5	-
Exaton 21.13.3.L (1 layer)		
-	8	-
Exaton 22.11.L		
-	6	-
Exaton 22.8.3.L Layer 1 with "22.11.L" & 2 layers with "22.8.3.L"		
-	45	-
Exaton 22.8.3.L Layer 1 with "22.8.3.L" & 2 layers with "22.8.3.L"		
-	45	-
Exaton 24.13.L		
-	3	-
Exaton 24.13.LNb (1 layer)		
-	13	0.6

Exaton 47S

Typical Weld Metal Analysis %		
Nb	FN WRC-92	Nb+Ta
Exaton 25.22.2.LMn (2 layers)		
-	0	-

Exaton 48S

Exaton 48S is a highly basic, agglomerated flux for electroslag strip surfacing. Used together with strip electrodes grades primarily for UREA applications such as SAFUREX and 29.8.2.L.

Specifications

Classifications	EN ISO 14174 : ES A FB 2B
------------------------	---------------------------

Welding Current	1700 A (60 x 0.5 mm strip)
Slag Type	Fluoride basic CaF ₂ -Al ₂ O ₃
Alloy Transfer	Moderately silicon alloying. Nickel adding.
Density	nom: 0.9 %
Basicity Index	nom: 3.5 %

Exaton 49S

Exaton 49S is a basic, agglomerated flux for electroslag strip surfacing. This flux is particularly intended for high-speed welding. In spite of high welding speed, flux Exaton 49S gives excellent slag removal and bead appearance, also for niobium-alloyed strip electrodes. It is used together with strip electrodes of the chromium, chromium-nickel and chromium-nickel-molybdenum steel types with or without niobium.

Specifications	
Classifications	EN ISO 14174 : ES A FB 2B
Welding Current	2200 A (Using 60x0.5 mm strip)
Slag Type	Fluoride basic CaF ₂ -Al ₂ O ₃
Density	nom: 1.0 Kg/l
Basicity Index	nom: 4.4

Flux Consumption
Volts
25 V

Conditions : Dimension , Amps , Travel Speed

Classifications	Wire
Wire	SFA/AWS - EN ISO
Exaton 19.12.3.L	A5.9:EQ316L 14343-A:B 19 12 3 L
Exaton 19.13.4.L	A5.9:EQ317L 14343-A:B 19 13 4 L
Exaton 19.9.L	A5.9:EQ308L 14343-A:B 19 9 L
Exaton 19.9.LNb	A5.9:EQ347 14343-A:B 19 9 Nb
Exaton 21.11.LNb	A5.9:EQ"309LNb" 14343-A:B 22 11 L Nb
Exaton 24.13.L	A5.9:EQ309L 14343-A:B 23 12 L
Exaton 24.13.LNb	A5.9:EQ309LNb 14343-A:B 23 12 Nb

Typical Weld Metal Analysis %									
C	Mn	Si	S	P	Ni	Cr	Mo	Cu	N
Exaton 19.12.3.L Layer 1 with "24.13.L"									
<=0.03	-	-	-	-	12.0	17.7	2.2	-	-
Exaton 19.13.4.L Layer 1 with "24.13.L"									
<=0.03	-	-	-	-	13.0	18.5	2.7	-	-
Exaton 19.9.L Layer 1 with "24.13.L"									
<=0.03	-	-	-	-	10	19.2	-	-	-
Exaton 19.9.LNb (Layer 1 with "24.13.L" & Layer 2 with "19.9.LNb")									
0.02	1.3	0.3	-	-	10.6	19.5	0.1	-	0.03
Exaton 19.9.LNb (Layer 1 with "24.13.LNb" & Layer 2 with "19.9.LNb")									
0.02	1.4	0.3	-	-	10.5	19.6	0.1	-	0.03
Exaton 21.11.LNb (1 layer)									
0.02	1.4	0.4	-	-	9.7	18.9	0.1	-	0.05
Exaton 24.13.L									
<=0.07	-	-	-	-	10.2	19	-	-	-

Exaton 49S

Typical Weld Metal Analysis %

C	Mn	Si	S	P	Ni	Cr	Mo	Cu	N
Exaton 24.13.LNb									
<=0.06	1.65	0.45	0.01	0.01	9.7	18.5	0.1	0.03	-

Typical Weld Metal Analysis %

Nb	FN WRC-92
Exaton 19.12.3.L Layer 1 with "24.13.L"	
-	6
Exaton 19.13.4.L Layer 1 with "24.13.L"	
-	6
Exaton 19.9.L Layer 1 with "24.13.L"	
-	8
Exaton 19.9.LNb (Layer 1 with "24.13.L" & Layer 2 with "19.9.LNb")	
0.3	-
Exaton 19.9.LNb (Layer 1 with "24.13.LNb" & Layer 2 with "19.9.LNb")	
0.4	-
Exaton 21.11.LNb (1 layer)	
0.5	-
Exaton 24.13.L	
-	6
Exaton 24.13.LNb	
0.45	5

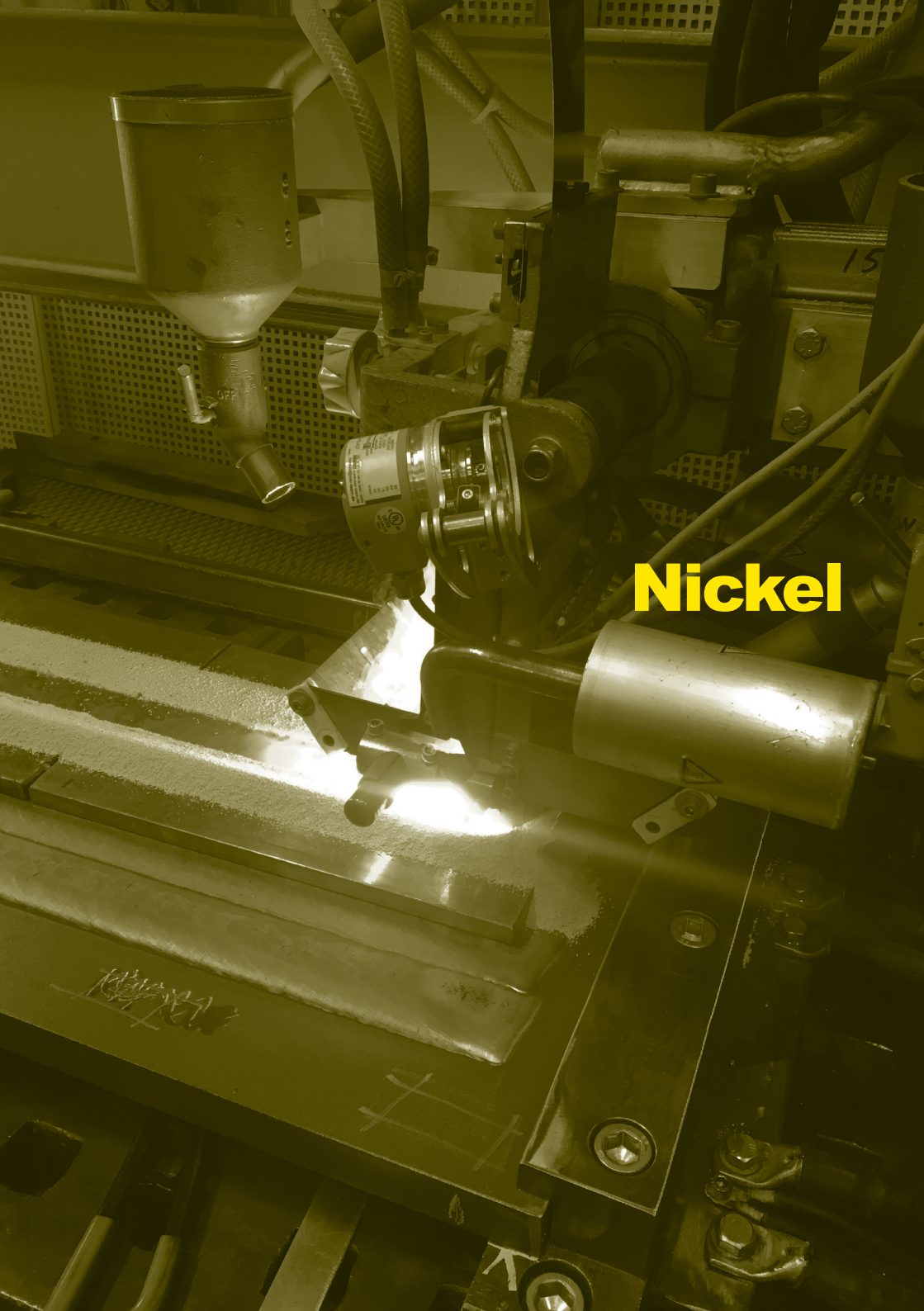

Nickel

Welding Nickel and Nickel Alloys.....	5-4
STICK ELECTRODES (SMAW).....	5-5
OK 92.55.....	5-5
OK Ni-1.....	5-6
OK Ni-CI.....	5-7
OK NiFe-CI-A.....	5-8
OK NiCrFe-2.....	5-9
OK NiCrFe-3.....	5-10
OK NiCrMo-3.....	5-11
OK NiCrMo-5.....	5-12
OK NiCu-1.....	5-13
OK NiCu-7.....	5-14
Exaton Ni59.....	5-15
Exaton Ni60.....	5-16
MIG WIRES/TIG RODS (GMAW/GTAW).....	5-17
OK Autrod Ni-1.....	5-17
OK Autrod NiCrMo-3.....	5-18
OK Autrod NiCrMo-4.....	5-20
OK Autrod NiCu-7.....	5-21
OK Tigrod Ni-1.....	5-22
OK Tigrod NiCrMo-3.....	5-23
OK Tigrod NiCrMo-4.....	5-24
OK Tigrod NiCu-7.....	5-25
Exaton Ni41Cu (GMAW).....	5-26
Exaton Ni53 (GMAW).....	5-27
Exaton Ni54 (GMAW).....	5-28
Exaton Ni55 (GMAW).....	5-29
Exaton Ni56 (GMAW).....	5-30
Exaton Ni59 (GMAW).....	5-31
Exaton Ni60 (GMAW).....	5-32
Exaton Ni60 Overlay.....	5-34
Exaton Ni72HP (GMAW).....	5-35
Exaton Ni41Cu (GTAW).....	5-36
Exaton Ni53 (GTAW).....	5-37
Exaton Ni54 (GTAW).....	5-38
Exaton Ni55 (GTAW).....	5-39
Exaton Ni56 (GTAW).....	5-40
Exaton Ni59 (GTAW).....	5-41
Exaton Ni60 (GTAW).....	5-42
Exaton Ni72HP (GTAW).....	5-43
GAS-SHIELDED FLUX-CORED WIRES (FCAW/MCAW).....	5-44
Cryo-Shield Ni9.....	5-44
Shield-Bright NiCrMo-3.....	5-45
SUBARC (SAW).....	5-46
OK Autrod NiCrMo-3.....	5-46
OK Autrod NiCrMo-4.....	5-47
OK Flux 10.16.....	5-48
OK Flux 10.17.....	5-49
OK Flux 10.90.....	5-50
OK Flux 10.93.....	5-52
OK Flux 10.99.....	5-56
Exaton Ni41Cu (SAW).....	5-58
Exaton Ni56 (SAW).....	5-59
Exaton Ni59 (SAW).....	5-60
Exaton Ni60 (SAW).....	5-61
Exaton Ni72HP (SAW).....	5-62
Exaton 15W.....	5-63
Exaton 50SW.....	5-66



STRIP CLADDING (SAW/ESW)	5-66
OK Band NiCrMo3	5-67
OK Band NiFeCr1	5-68
OK Flux 10.11	5-69
OK Flux 10.16	5-70
OK Flux 10.17	5-71
Exaton Ni41Cu (ESW).....	5-72
Exaton Ni56 (ESW)	5-73
Exaton Ni60 (ESW)	5-74
Exaton Ni72HP (ESW)	5-75
Exaton 50SW	5-76
Exaton 69S.....	5-77
Exaton 79S.....	5-78

1. General

Nickel and nickel alloys are predominantly used in chemical equipment construction where demands for corrosion/heat resistance and creep rupture strength are high. Nickel alloys are categorised based on the type and quantity of elements added:

- Pure nickel
- Nickel-copper alloys
- Nickel-chromium-iron alloys
- Nickel-chromium alloys
- Nickel-molybdenum alloys
- Nickel-chromium-molybdenum alloys

The alloy types listed are each adapted to one or more specific corrosive agents. Resistance to sulphuric, phosphoric, hydrochloric and nitric acid as well as concentrated alkaline solutions and sea water is particularly important.

2. Welding Instructions

Similar guidelines apply to welding nickel and nickel alloys as for stainless steels. Here too, the top priority is the cleanliness of the welding point.

The joint preparation area should be clean and degreased using suitable cleaning agents before welding work begins. Otherwise, the sulphur contained in oil, fat and furnace gas residues will cause a low-melting eutectic to form, which will result in hot cracking in the weld metal and heat-affected zone. The joint preparation should preferably be done mechanically by turning, milling or grinding.

The issue of pore formation during welding due to the presence of oxygen, nitrogen and especially hydrogen can be counteracted using electrodes directly from an ESAB VacPac™ or by re-baking the electrodes and flux, as well as welding with the shortest possible arc.

The same rules apply to heat management as for welding austenitic stainless steels, ie welding should be carried out with a low heat input of about 8 – 12 kJ/cm (stringer bead technique). The weaving width of the weave beads produced during MMA welding must be limited to 2.5 times the core rod diameter.

The interpass temperature should not exceed 150°C (in many cases also 100°C or 120°C). The welding bead can be post-weld treated by grinding, brushing or pickling (see instructions for welding stainless steels).

OK 92.55



An all position basic coated electrode depositing a nickel chromium based alloy with additions of molybdenum, tungsten and niobium. The electrode is especially designed for welding of 9% nickel steels for cryogenic applications down to -196°C. Typical application is land based LNG tanks.

Specifications	
Classifications	SFA/AWS A5.11 : ENiCrMo-6 EN ISO 14172 : E Ni 6620 (NiCr14Mo7Fe)
Approvals	ABS : ENiCrMo-6 BV : ENiCrMo-6 CCS : 5Ni, 9Ni ClassNK : KMWL92 DNV-GL : VL 1.5Ni up to VL 9Ni * KR : L 91 LR : 9Ni RINA : N90

Approvals are based on factory location. Please contact ESAB for more information.

Welding Current	AC, DC+-
Alloy Type	Ni-based CrMoNb
Coating Type	Basic
Min AC OCV	55

Typical Tensile Properties			
Condition	Yield Strength	Tensile Strength	Elongation
ISO			
As Welded	445 MPa	727 MPa	40 %

Typical Charpy V-Notch Properties		
Condition	Testing Temperature	Impact Value
ISO		
As Welded	-196 °C	91 J

Typical Weld Metal Analysis %								
C	Mn	Si	Ni	Cr	Mo	Nb	W	Fe
0.05	3.0	0.3	69.4	12.9	6.2	1.3	1.6	5.0

Deposition Data					
Diameter	Current	Voltage	Efficiency (%)	Fusion time per electrode at 90% I max	Deposition Rate
2.5 x 350 mm	65-115 A	23 V	70 %	70 sec	1.1 kg/h
3.2 x 350 mm	70-150 A	22 V	66 %	68 sec	1.5 kg/h
4.0 x 350 mm	120-200 A	22 V	67 %	82 sec	1.9 kg/h
5.0 x 350 mm	150-240 A	23 V	68 %	91 sec	2.8 kg/h

OK Ni-1



A stick electrode for joining commercially pure nickel in wrought and cast forms. Also for joining dissimilar metals such as nickel to steel, nickel to copper and copper to steel. The electrode can also be used for surfacing steel.

Specifications

Classifications	SFA/AWS A5.11 : ENi-1 EN ISO 14172 : E Ni 2061 (NiTi3)
------------------------	---

Welding Current	DC+
Alloy Type	Nickel-base
Coating Type	Lime Basic

Typical Tensile Properties

Condition	Yield Strength	Tensile Strength	Elongation
ISO			
As Welded	330 MPa	470 MPa	30 %

Typical Weld Metal Analysis %

C	Mn	Si	Ni	Al	Ti	Fe
0.04	0.4	0.7	96	0.10	1.5	0.4

Deposition Data

Diameter	Current	Efficiency (%)	Fusion time per electrode at 90% I max	Deposition Rate
2.5 x 300 mm	70-95 A	55 %	47 sec	0.8 kg/h
3.2 x 350 mm	90-135 A	55 %	56 sec	1.2 kg/h

OK Ni-CI



OK Ni-CI is a nickel cored electrode for joining normal grades of cast iron, such as grey-, ductile- and malleable irons. It is also suitable for rectification and repair of these grades and for joining them to steel. Deposition is done on cold or slightly preheated cast iron. Weld metal is well machinable. Typical applications are repair of cast iron parts such as cracks in engine blocks, pump housings, gear boxes, frames as well as foundry defects.

Specifications

Classifications	SFA/AWS A5.15 : ENi-CI EN ISO 1071 : E C Ni-CI 3
Welding Current	AC, DC+-
Alloy Type	Ni-base alloy
Coating Type	Basic Special high graphite
Min AC OCV	50

Typical Weld Metal Analysis %

C	Mn	Si	Ni	Al	Cu	Fe
1.0	0.2	0.3	93.5	0.1	0.3	4.5

Deposition Data

Diameter	Current	Voltage	Efficiency (%)	Fusion time per electrode at 90° I max	Deposition Rate
2.5 x 300 mm	55-110 A	21 V	71 %	46 sec	0.9 kg/h
3.2 x 350 mm	80-140 A	20 V	68 %	66 sec	1.2 kg/h
4.0 x 350 mm	100-190 A	19 V	70 %	71 sec	1.7 kg/h

OK NiFe-CI-A



A nickel-iron cored electrode for joining normal grades of cast iron, such as grey-, ductile- and malleable irons. It is also suitable for rectification and repair of these grades and for joining them to steel. Deposition is done on cold or slightly preheated cast iron. The electrode produces a weld metal stronger and more resistant to solidification cracking than electrode type of pure nickel type. It is specially suited for high duty welds in ductile irons and for welding grey irons with increased contents of sulphur and phosphorous. Typical applications include repair of pump bodies, heavy machine sections, gear teeth, flanges and pulleys.

Specifications

Classifications	SFA/AWS A5.15 : ENiFe-CI-A EN ISO 1071 : E C NiFe-CI-A 1
Approvals	CE : EN 13479 UKCA : EN 13479

Approvals are based on factory location. Please contact ESAB for more information.

Welding Current	AC, DC+-
Alloy Type	Ni-Fe alloy
Coating Type	Basic Special high graphite
Min AC OCV	50

Typical Weld Metal Analysis %

C	Mn	Si	Ni	Al	Fe
1.5	0.8	0.7	51	1.4	46

Deposition Data

Diameter	Current	Efficiency (%)	Fusion time per electrode at 90% I max	Deposition Rate
2.5 x 300 mm	55-75 A	70 %	70 sec	0.6 kg/h
3.2 x 350 mm	75-100 A	70 %	90 sec	0.9 kg/h
4.0 x 350 mm	85-160 A	70 %	70 sec	1.8 kg/h

OK NiCrFe-2



Nickel based electrode for welding Inconel 600 and similar alloys, cryogenic steels (e.g. 9% and 5% Ni steel), martensitic to austenitic steels, dissimilar steels, heat resisting steel castings of limited weldability etc. Good weldability in all positions, including overhead.

Specifications

Classifications	SFA/AWS A5.11 : ENiCrFe-2 EN ISO 14172 : E Ni 6133 (NiCr16Fe12NbMo)
Approvals	ABS

Approvals are based on factory location. Please contact ESAB for more information.

Welding Current	DC+
Alloy Type	Nickel alloy
Coating Type	Basic

Typical Tensile Properties

Condition	Yield Strength	Tensile Strength	Elongation
AWS			
1.PWHT 4.5 hour(s) 982 °C	329 MPa	673 MPa	50 %
2.PWHT 4.5 hour(s) 982 °C	321 MPa	668 MPa	50 %
3.PWHT 4.5 hour(s) 982 °C	239 MPa	526 MPa	44 %
4.PWHT 4.5 hour(s) 982 °C	233 MPa	515 MPa	46 %
As Welded	420 MPa	660 MPa	45 %

Typical Charpy V-Notch Properties

Condition	Testing Temperature	Impact Value
AWS		
As Welded	20 °C	110 J
1.PWHT 4.5 hour(s) 982 °C	-60 °C	122 J
2.PWHT 4.5 hour(s) 982 °C	-60 °C	118 J
As Welded	-196 °C	90 J

Typical Weld Metal Analysis %

C	Mn	Si	Ni	Cr	Mo	Nb	Fe
0.03	2.7	0.5	69	16.1	1.9	1.9	7.7

Deposition Data

Diameter	Current	Voltage	Efficiency (%)	Fusion time per electrode at 90° I max	Deposition Rate
2.5 x 300 mm	50-80 A	22 V	63 %	45 sec	0.9 kg/h
3.2 x 350 mm	70-105 A	23 V	62 %	57 sec	1.3 kg/h
4.0 x 350 mm	95-140 A	24 V	65 %	58 sec	2.1 kg/h

OK NiCrFe-3



OK NiCrFe-3 is a nickel based electrode for welding Inconel 600 and similar Inconel alloys, cryogenic steels, martensitic to austenitic steels, dissimilar steels, heat resisting steel castings of limited weldability. OK NiCrFe-3 provides a very crack resistant weld metal.

Specifications

Classifications	SFA/AWS A5.11 : ENiCrFe-3 EN ISO 14172 : E Ni 6182 (NiCr15Fe6Mn)
Welding Current	DC+
Alloy Type	Ni-based Cr-alloy
Coating Type	Basic

Typical Tensile Properties

Condition	Yield Strength	Tensile Strength	Elongation
AWS			
As Welded	395 MPa	640 MPa	42 %
ISO			
PWHT 8 hour(s) 620 °C	433 MPa	683 MPa	44 %

Typical Charpy V-Notch Properties

Condition	Testing Temperature	Impact Value
AWS		
As Welded	20 °C	110 J
As Welded	-196 °C	95 J
ISO		
PWHT 8 hour(s) 620 °C	20 °C	128 J

Typical Weld Metal Analysis %

C	Mn	Si	Ni	Cr	Nb	Fe
0.04	6.7	0.8	71	15.6	1.7	6.3

Deposition Data

Diameter	Current	Voltage	Efficiency (%)	Fusion time per electrode at 90% I max	Deposition Rate
2.5 x 300 mm	50-70 A	22 V	63 %	50 sec	0.9 kg/h
3.2 x 350 mm	65-105 A	23 V	62 %	60 sec	1.2 kg/h
4.0 x 350 mm	75-150 A	24 V	64 %	60 sec	2.0 kg/h
5.0 x 350 mm	120-170 A	25 V	64 %	68 sec	2.7 kg/h

OK NiCrMo-3



Ni-based CrMoNb electrode for welding of Ni-alloys of the same or similar type as e.g. Inconel 625, for welding of 5% and 9% Ni steel. The electrode is very suitable for welding of 254 SMO, i.e. UNS S31254 steel.

Specifications

Classifications	SFA/AWS A5.11 : ENiCrMo-3 EN ISO 14172 : E Ni 6625 (NiCr22Mo9Nb)
Approvals	DNV-GL : -H5 VdTÜV : 12414

Approvals are based on factory location. Please contact ESAB for more information.

Welding Current	DC+
Ferrite Content	FN 0
Alloy Type	Ni-based CrMoNb
Coating Type	Basic

Typical Tensile Properties

Condition	Yield Strength	Tensile Strength	Elongation
ISO			
As Welded	520 MPa	820 MPa	38 %

Typical Charpy V-Notch Properties

Condition	Testing Temperature	Impact Value
ISO		
As Welded	20 °C	70 J
As Welded	-196 °C	65 J

Typical Weld Metal Analysis %

C	Mn	Si	Ni	Cr	Mo	Nb	Fe
0.03	0.2	0.4	62.8	21.7	9.3	3.3	2.0

Deposition Data

Diameter	Current	Voltage	Efficiency (%)	Fusion time per electrode at 90% I max	Deposition Rate
2.5 x 300 mm	55-75 A	23 V	55 %	40 sec	0.9 kg/h
3.2 x 350 mm	65-100 A	25 V	56 %	52 sec	1.4 kg/h
4.0 x 350 mm	80-140 A	27 V	58 %	57 sec	1.9 kg/h
5.0 x 350 mm	120-170 A	24 V	58 %	72 sec	2.1 kg/h

OK NiCrMo-5



OK NiCrMo-5 deposits an all weld metal that is similar to AWS classification ENiCrMo-5. The all weld metal consists of a Ni-Cr-Mo-W alloy of Hastelloy C type. The weld metal is tough and work hardens. The high temperature properties regarding tensile strength, hardness, thermal shock and scaling are good. It is resistant to damp chlorine gas and to hydrochloric-, nitric-, sulphuric- and phosphoric acids at room temperature. Typical applications and welding procedures recommendations are given under the heading "Other Data".

Specifications

Classifications	EN 14700 : E Z Ni2
Welding Current	DC+, AC
Alloy Type	Nickel alloy
Coating Type	Rutile Basic
Min AC OCV	70

Typical Tensile Properties

Condition	Yield Strength	Tensile Strength	Elongation
ISO			
As Welded	515 MPa	750 MPa	17 %

Typical Weld Metal Analysis %

C	Mn	Si	Ni	Cr	Mo	W	Fe
0.05	0.9	0.5	57.5	15.5	16.4	3.5	5.5

Deposition Data

Diameter	Current	Voltage	Efficiency (%)	Fusion time per electrode at 90° I max	Deposition Rate
2.5 x 300 mm	65-110 A	18 V	61 %	62 sec	1.1 kg/h
3.2 x 350 mm	110-150 A	18 V	63 %	86 sec	1.6 kg/h
4.0 x 350 mm	160-200 A	20 V	64 %	89 sec	2.3 kg/h
5.0 x 350 mm	190-250 A	20 V	65 %	106 sec	3.1 kg/h

OK NiCu 1



OK NiCu 1 is a nickel-copper cored electrode of monel type for welding normal grades of cast iron such as gray-, ductile- and malleable irons. Deposition is done on cold or slightly preheated material. The weld metal is well machinable and provides a good colour match to that of cast iron.

Specifications

Classifications	EN ISO 1071 : E C NiCu 1
Welding Current	AC, DC+-
Alloy Type	Nickel-copper alloy
Coating Type	Basic Special
Min AC OCV	45

Typical Weld Metal Analysis %

C	Mn	Ni	Cu	Fe
0.3	0.9	65	31	3

Deposition Data

Diameter	Current	Voltage	Efficiency (%)	Fusion time per electrode at 90% I max	Deposition Rate
2.5 x 300 mm	50-100 A	18 V	60 %	66 sec	0.6 kg/h
3.2 x 350 mm	60-125 A	18 V	65 %	97 sec	0.8 kg/h

OK NiCu-7



OK NiCu-7 is used for welding NiCu-alloys. It can also be used to connect a NiCu alloy to a mild- and low alloy steel. This can only be done after the mild or low alloy steel surface has been buttered using a pure nickel grade such as OK Ni-1. OK NiCu-7 can be used for cladding of mild and low alloy steel after a buffer layer of nickel has been deposited.

Specifications

Classifications	SFA/AWS A5.11 : ENiCu-7 EN ISO 14172 : E Ni 4060 (NiCu30Mn3Ti)
Welding Current	DC+
Ferrite Content	FN 0
Alloy Type	NiCu-alloy
Coating Type	Basic

Typical Tensile Properties

Condition	Yield Strength	Tensile Strength	Elongation
AWS			
As Welded	410 MPa	640 MPa	40 %

Typical Charpy V-Notch Properties

Condition	Testing Temperature	Impact Value
AWS		
As Welded	20 °C	100 J
As Welded	-196 °C	80 J

Typical Weld Metal Analysis %

C	Mn	Si	Ni	Cu	Ti	Fe
0.02	3.0	0.5	66	29	0.4	1.9

Deposition Data

Diameter	Current	Voltage	Efficiency (%)	Fusion time per electrode at 90% I max	Deposition Rate
2.5 x 300 mm	50-70 A	22 V	63 %	45 sec	1.0 kg/h
3.2 x 350 mm	70-120 A	26 V	63 %	52 sec	1.6 kg/h
4.0 x 350 mm	120-140 A	28 V	63 %	54 sec	2.4 kg/h

Exaton Ni59



Exaton Ni59 is nickel chromium molybdenum alloy of the type UNS N065059. It is a versatile alloy with excellent wet corrosion resistance for the most demanding applications. It combines excellent corrosion resistance in oxidizing and reducing media, has excellent resistance in chloride containing media and to localized corrosion environments. The grade has excellent thermal stability compared to other nickel alloys, and has therefore outstanding resistance to intermetallic precipitation during welding. The microstructure is fully austenitic. Exaton Ni59 is used for joining matching alloys or dissimilar joining to other nickel alloys such as UNS N10276 (2.4819), type UNS N06022 (2.4602), UNS N06625 (2.4856) and N08825 (2.4858). It provides strong, tough, Nb free weld metal for dissimilar welds in super austenitic and super duplex stainless steel joints or combinations of these with nickel alloys. Typical applications are: contaminated mineral acid environments such as sulfuric acid, hydrochloric acid, phosphoric acid, nitric acid etc, components in sulphuric acid coolers, digesters and bleachers, chemical, petrochemical, marine, pharmaceutical, energy production and pollution control.

Specifications

Classifications	SFA/AWS A5.11 : ENiCrMo-13 EN ISO 14172 : E Ni 6059 (NiCr23Mo16)
------------------------	---

Welding Current	DC+
Alloy Type	Ni-based CrMo
Coating Type	Basic

Typical Tensile Properties

Condition	Yield Strength	Tensile Strength	Elongation
ISO			
As Welded	500 MPa	790 MPa	35 %

Typical Charpy V-Notch Properties

Condition	Testing Temperature	Impact Value
ISO		
As Welded	20 °C	60 J
As Welded	-196 °C	40 J

Typical Weld Metal Analysis %

C	Mn	Si	S	P	Ni	Cr	Mo	Fe
0.01	0.2	0.15	0.006	0.006	60	23	16	1

Deposition Data

Diameter	Current	Voltage	Efficiency (%)	Fusion time per electrode at 90% I max	Deposition Rate
2.5 x 300 mm	50-70 A	25 V	60 %	50 sec	0.8 kg/h
3.2 x 350 mm	60-90 A	25 V	62 %	63 sec	1.2 kg/h
4.0 x 350 mm	80-120 A	27 V	62 %	81 sec	1.4 kg/h

Exaton Ni60



Exaton Ni60 is a nickel-chromium-molybdenum covered electrode for welding of Ni/Cr/Mo nickel alloys, highalloy stainless steels and 5-9%Ni steels in cryogenic applications. It can be used in many variants of dissimilar joining of nickel alloys, stainless steels and low alloyed steels. Exaton Ni60 can also be used for overlay welding on low alloyed steels. The electrode combines good welding properties in all positions with very low impurity levels, high impact strength and excellent corrosion resistance to pitting in chloride containing media and stress corrosion cracking. Typical applications for Exaton Ni60 include components in the chemical and petrochemical industries often in connection with sea-water cooling where pitting corrosion and stress corrosion cracking are a risk, pressure vessels, heat exchangers etc. It is also used in sour gas service where it is approved by ISO 15156/NACE MR0175. Common base materials welded are ASTM UNS: S31254, N06625, N08825 and N08020.

Specifications

Classifications	SFA/AWS A5.11 : ENiCrMo-3 EN ISO 14172 : E Ni 6625 (NiCr22Mo9Nb)
Approvals	VdTÜV : 04796

Approvals are based on factory location. Please contact ESAB for more information.

Welding Current	DC+
Alloy Type	Ni-based CrMoNb
Coating Type	Basic

Typical Tensile Properties

Condition	Yield Strength	Tensile Strength	Elongation
ISO			
As Welded	520 MPa	820 MPa	38 %

Typical Charpy V-Notch Properties

Condition	Testing Temperature	Impact Value
ISO		
As Welded	20 °C	70 J
As Welded	-196 °C	65 J

Typical Weld Metal Analysis %

C	Mn	Si	S	P	Ni	Cr	Mo	Cu	Nb
0.03	0.23	0.4	<=0.01	<=0.015	63	22	9	0.01	3.4

Typical Weld Metal Analysis %

Others tot	Fe	Nb+Ta
<=0.50	<=2	3.4

Deposition Data

Diameter	Current	Voltage	Efficiency (%)	Fusion time per electrode at 90% I max	Deposition Rate
2.5 x 300 mm	55-75 A	23 V	55 %	40 sec	0.9 kg/h
3.2 x 350 mm	65-100 A	25 V	56 %	52 sec	1.4 kg/h
4.0 x 350 mm	80-140 A	27 V	58 %	57 sec	1.9 kg/h
5.0 x 350 mm	120-170 A	24 V	58 %	72 sec	2.1 kg/h

OK Autrod Ni-1

A continuous solid nickel based electrode alloyed with about 3 % Ti for welding of high purity nickel (min 99.6 %Ni), ordinary wrought nickel and nickel with reduced C content. The weld metal can be used in a wide range of applications where the construction is working with corrosive media.

Specifications

Classifications	SFA/AWS A5.14 : ERNi-1 EN ISO 18274 : S Ni 2061 (NiTi3)
Approvals	VdTÜV : 12658 (MV) VdTÜV : 12664 (FP)

Approvals are based on factory location. Please contact ESAB for more information.

Alloy Type	Nickel (Ni + 2.5 % Ti)
Shielding Gas	11, 12, 13 (EN ISO 14175)

Typical Tensile Properties

Condition	Yield Strength	Tensile Strength	Elongation
As Welded	200 MPa	410 MPa	25 %

Typical Charpy V-Notch Properties

Condition	Testing Temperature	Impact Value
As Welded	20 °C	130 J

Typical Weld Metal Analysis %

C	Mn	Si	S	P	Ni	Al	Cu	Ti	Fe
0.02	0.4	0.3	0.01	0.01	93	0.1	0.1	3	0.2

Typical Wire Composition %

C	Mn	Si	Ni	Al	Cu	Ti	Fe
0.01	0.4	0.5	96	0.06	0.01	3.1	0.04

Deposition Data

Diameter	Current	Voltage	Wire Feed Speed	Deposition Rate
0.8 mm	70-190 A	20-27 V	5.0-18.0 m/min	1.3-4.8 kg/h
1.0 mm	100-200 A	21-27 V	6.0-13.0 m/min	2.5-5.5 kg/h

OK Autrod NiCrMo-3

Bare corrosion and heat-resisting Ni-Cr-Mo rod for welding of high alloyed heat-resisting and corrosion resisting materials, 9%Ni-steels and similar steels with high notch toughness at low temperatures. The filler metal is also used for welding of dissimilar joints containing non- and low alloyed steel. The weld metal has good mechanical properties at high and low temperatures. Good resistance to pitting corrosion and stress corrosion cracking. The alloy is extensively required for weld cladding of valve components and pipe inner diameters in oil and gas applications.

Specifications

Classifications	SFA/AWS A5.14 : ERNiCrMo-3 EN ISO 18274 : S Ni 6625
Approvals	DNV-GL : 1.2 mm VdTÜV : 12413

Approvals are based on factory location. Please contact ESAB for more information.

Alloy Type	Alloyed nickel (Ni + 22 % Cr + 9 % Mo - 3.5 % Nb)
Shielding Gas	11, I3, M12 (EN ISO 14175)

Typical Tensile Properties

Condition	Yield Strength	Tensile Strength	Elongation
As Welded	500 MPa	780 MPa	45 %
As Welded+	380 MPa	580 MPa	48 %
Stress Relieved 15 hour(s) 550 °C	490 MPa	796 MPa	40 %
SHT 0.5 hour(s) 1175 °C	375 MPa	765 MPa	46 %
SHT+ 0.5 hour(s) 1175 °C	270 MPa	590 MPa	46 %

Typical Charpy V-Notch Properties

Condition	Testing Temperature	Impact Value
As Welded	20 °C	130 J
Stress Relieved 15 hour(s) 550 °C	20 °C	140 J
SHT 0.5 hour(s) 1175 °C	20 °C	185 J
As Welded	-105 °C	120 J
SHT 0.5 hour(s) 1175 °C	-105 °C	170 J
As Welded	-196 °C	110 J
Stress Relieved 15 hour(s) 550 °C	-196 °C	120 J
SHT 0.5 hour(s) 1175 °C	-196 °C	150 J

Typical Weld Metal Analysis %

C	Mn	Si	S	P	Ni	Cr	Mo	Al	Cu
0.011	0.05	0.05	0.001	0.004	65	21.8	8.7	0.09	0.01

Typical Weld Metal Analysis %

Ti	Fe	Nb+Ta
0.19	0.37	3.56

OK Autrod NiCrMo-3

Typical Wire Composition %

C	Mn	Si	Ni	Cr	Mo	Fe	Nb+Ta
0.02	0.04	0.06	Bal	22.7	8.6	0.3	3.5

Deposition Data

Diameter	Current	Voltage	Wire Feed Speed	Deposition Rate
0.9 mm	80-190 A	20-27 V	5.0-16.0 m/min	2.0-4.2 kg/h
1.0 mm	100-200 A	21-27 V	6.0-13.0 m/min	2.5-5.5 kg/h
1.14 mm	130-240 A	22-28 V	6.0-12.0 m/min	3.0-5.7 kg/h
1.2 mm	160-280 A	24-30 V	6.0-10.0 m/min	3.6-6.0 kg/h
1.6 mm	200-350 A	25-32 V	4.0-8.0 m/min	4.3-8.6 kg/h

OK Autrod NiCrMo-4

OK Autrod NiCrMo-4 is a corrosion and heat resistant, nickel-chromium wire suitable for welding high alloyed steel, heat resistant steel, corrosion resistant steel, 9Ni steels and similar steels with high notch toughness at low temperatures. The alloy has good resistance to stress corrosion cracking.

Specifications

Classifications	SFA/AWS A5.14 : ERNiCrMo-4 EN ISO 18274 : S Ni 6276 (NiCr15Mo16Fe6W4)
------------------------	--

Alloy Type	Nickel alloy - 16% Cr - 16% Mo - 5% Fe - 3.5 % W - Low C
Shielding Gas	M12 (EN ISO 14175)

Typical Tensile Properties

Condition	Yield Strength	Tensile Strength	Elongation
As Welded	490 MPa	732 MPa	42.5 %

Typical Charpy V-Notch Properties

Condition	Testing Temperature	Impact Value
As Welded	-30 °C	130 J
As Welded	-196 °C	112 J

Typical Weld Metal Analysis %

C	Mn	Si	S	P	Ni	Cr	Mo	V	Al
0.012	0.55	<0.05	<0.001	0.005	59	15.6	15.6	0.02	0.05

Typical Weld Metal Analysis %

Cu	Nb	Ti	Co	B	Ta	W	Fe
0.03	<0.05	0.01	<0.01	0.001	0.01	3.61	6.3

Typical Wire Composition %

C	Mn	Si	Ni	Cr	Mo	W	Fe
0.01	0.45	0.05	Bal.	15.5	16.1	3.5	5.8

Deposition Data

Diameter	Current	Voltage	Wire Feed Speed	Deposition Rate
1.0 mm	100-200 A	21-27 V	6.0-13.0 m/min	2.5-5.5 kg/h
1.2 mm	160-280 A	24-30 V	6.0-10.0 m/min	3.6-6.0 kg/h

OK Autrod NiCu-7

A continuous solid nickel based electrode alloyed with 30 % Cu for welding of base materials of the same type. Can also be used to join these alloys to steel. The weld metal has good resistance to flowing seawater and has high strength and toughness over a rather wide temperature range. This alloy also has good resistance to hydrofluoric acid, sulfuric acid, alkalis etc. Can be used for welding of similar types of base materials which are age-hardenable with small additions of Ti and Al. Usable for cladding on carbon steel with an intermediate layer of OK Autrod Ni-1.

Specifications	
Classifications	SFA/AWS A5.14 : ERNiCu-7 EN ISO 18274 : S Ni 4060 (NiCu30Mn3Ti)
Approvals	VdTÜV : 12660 (MV) VdTÜV : 12668 (FP)

Approvals are based on factory location. Please contact ESAB for more information.

Alloy Type	Alloyed nickel (Ni + 30 % Cu + 2 % Ti + 2 % Fe)
Shielding Gas	11, I3 (EN ISO 14175)

Typical Tensile Properties			
Condition	Yield Strength	Tensile Strength	Elongation
As Welded	300 MPa	520 MPa	35 %

Typical Weld Metal Analysis %									
C	Mn	Si	S	P	Ni	Al	Cu	Nb	Ti
0.01	3.3	0.06	0.001	0.001	64	0.1	30	0.009	1.8

Typical Weld Metal Analysis %		
Ta	Fe	Nb+Ta
0.003	0.7	0.012

Typical Wire Composition %								
C	Mn	Si	Ni	Al	Cu	Ti	Fe	Nb+Ta
0.03	3	0.3	64	0.03	28	2	2	< 0.5

Deposition Data				
Diameter	Current	Voltage	Wire Feed Speed	Deposition Rate
1.0 mm	100-200 A	21-27 V	6.0-13.0 m/min	2.5-5.5 kg/h
1.2 mm	160-280 A	24-30 V	6.0-10.0 m/min	3.6-6.0 kg/h
1.6 mm	200-350 A	25-32 V	4.0-8.0 m/min	4.3-8.6 kg/h

OK Tigrod Ni-1

A bare nickel based rod alloyed with about 3 % Ti for welding of high purity nickel (min 99.6 %Ni), ordinary wrought nickel and nickel with reduced C content. The weld metal can be used in a wide range of applications where the construction is working with corrosive media.

Specifications

Classifications	SFA/AWS A5.14 : ERNi-1 EN ISO 18274 : S Ni 2061 (NiTi3)
Approvals	VdTÜV : 12659 VdTÜV : 12665

Approvals are based on factory location. Please contact ESAB for more information.

Alloy Type	Nickel (Ni + 2.5 % Ti)
Shielding Gas	11, 12, 13 (EN 439)

Typical Weld Metal Analysis %

C	Mn	Si	S	P	Ni	Al	Cu	Ti	Fe
0.02	0.4	0.3	0.01	0.01	93	0.1	0.1	3	0.2

Typical Wire Composition %

C	Mn	Si	Ni	Al	Cu	Ti	Fe
0.01	0.4	0.5	96	0.06	0.01	3.1	0.04

OK Tigrod NiCrMo-3

Bare corrosion and heat-resisting Ni-Cr-Mo rod for welding of high alloyed heat-resisting and corrosion resisting materials, 9%Ni-steels and similar steels with high notch toughness at low temperatures. The filler metal is also used for welding of dissimilar joints containing non- and low alloyed steel. The weld metal has good mechanical properties at high and low temperatures. Good resistance to pitting corrosion and stress corrosion cracking.

Specifications	
Classifications	SFA/AWS A5.14 : ERNiCrMo-3 EN ISO 18274 : S Ni 6625
Approvals	BV : ERNiCrMo-3 DNV-GL : 2.4 mm VdTUV : 12460

Approvals are based on factory location. Please contact ESAB for more information.

Alloy Type	Alloyed nickel (Ni + 22 % Cr + 9 % Mo - 3.5 % Nb)
Shielding Gas	I1, I3, R1 (EN ISO 14175)

Typical Tensile Properties			
Condition	Yield Strength	Tensile Strength	Elongation
As Welded	550 MPa	780 MPa	40 %

Typical Charpy V-Notch Properties		
Condition	Testing Temperature	Impact Value
As Welded	-196 °C	100 J

Typical Weld Metal Analysis %									
C	Mn	Si	S	P	Ni	Cr	Mo	Al	Cu
0.009	<0.05	0.08	0.001	0.004	63	22.1	9.1	0.09	<0.01

Typical Weld Metal Analysis %		
Ti	Fe	Nb+Ta
0.18	1.41	3.47

Typical Wire Composition %							
C	Mn	Si	Ni	Cr	Mo	Fe	Nb+Ta
0.02	0.04	0.06	Bal	22.7	8.6	0.3	3.5

OK Tigrod NiCrMo-4

OK Tigrod NiCrMo-4 is a corrosion and heat resistant nickel-chromium rod for TIG welding of high alloyed heat resistant steels as well as corrosion resistant 9Ni steels and similar steels with high impact toughness requirements at low temperatures. The grade has good resistance to stress corrosion cracking.

Specifications

Classifications	SFA/AWS A5.14 : ERNiCrMo-4 EN ISO 18274 : S Ni 6276 (NiCr15Mo16Fe6W4)
Approvals	ABS : 2.4mm DNV : 1.6 - 2.4mm

Approvals are based on factory location. Please contact ESAB for more information.

Alloy Type	Alloyed nickel (Ni + 16 % Cr + 16% Mo + 3.7% W + 5.9 % Fe + Low C)
Shielding Gas	I1 (EN ISO 14175)

Typical Tensile Properties

Condition	Yield Strength	Tensile Strength	Elongation
As Welded	530 MPa	760 MPa	44 %

Typical Charpy V-Notch Properties

Condition	Testing Temperature	Impact Value
As Welded	-110 °C	170 J
As Welded	-196 °C	175 J

Typical Weld Metal Analysis %

C	Mn	Si	S	P	Ni	Cr	Mo	V	Al
0.006	0.48	<0.05	<0.001	0.006	58	15.5	15.5	0.02	0.06

Typical Weld Metal Analysis %

Cu	N	Nb	Ti	Co	B	Ta	W	Fe	O
0.04	0.012	<0.05	<0.01	0.03	0.001	0.01	3.45	6.6	0.004

Typical Wire Composition %

C	Mn	Si	Ni	Cr	Mo	W	Fe
0.01	0.45	0.05	Bal.	15.5	16.1	3.5	5.8

OK Tigrod NiCu-7

Bare nickel based welding rods alloyed with 30 % Cu for welding of base materials of the same type. Can also be used to join these alloys to steel. The weld metal has good resistance to flowing seawater and has high strength and toughness over a rather wide temperature range. Has also good resistance to hydrofluoric acid, sulfuric acid, alkalis etc. Can be used for welding of similar types of base materials which are age-hardenable with small additions of Ti and Al.

Specifications	
Classifications	SFA/AWS A5.14 : ERNiCu-7 EN ISO 18274 : S Ni 4060 (NiCu30Mn3Ti)
Approvals	VdTÜV : 12661 (MV) VdTÜV : 12669 (FP)

Approvals are based on factory location. Please contact ESAB for more information.

Alloy Type	Alloyed nickel (Ni + 30 % Cu + 2 % Ti + 2 % Fe)
Shielding Gas	11 (EN ISO 14175)

Typical Tensile Properties			
Condition	Yield Strength	Tensile Strength	Elongation
As Welded	300 MPa	520 MPa	35 %

Typical Weld Metal Analysis %									
C	Mn	Si	S	P	Ni	Al	Cu	Nb	Ti
0.01	3.2	0.06	0.001	0.001	64	0.1	30	0.002	1.8

Typical Weld Metal Analysis %		
Ta	Fe	Nb+Ta
0.003	0.7	0.005

Typical Wire Composition %								
C	Mn	Si	Ni	Al	Cu	Ti	Fe	Nb+Ta
0.03	3	0.3	64	0.03	28	2	2	< 0.5

Exaton Ni41Cu (GMAW)

Exaton Ni41Cu welding wire is suitable for overlay welding when a deposit with chemistry corresponding to UNS N08825 is required. The weld deposit is a nickel-iron-chromium-molybdenum-copper alloy suitable for use in corrosive environments. Exaton Ni41Cu can also be used for dissimilar joining of stainless steels to nickel alloys and plasma welding and overlay welding using hot wire TIG and mechanized TIG. Exaton Ni41Cu has very good resistance to stress corrosion cracking (SCC) in chloride containing environments and is particularly suited for use in reducing environments such as those containing sulphuric and phosphoric acids. Exaton Ni41Cu is used for corrosion resistant alloy surfacing of components in the chemical, pollution control, oil and gas and petrochemical industries and often in connection with sour gas service. Typical components are tanks, heat exchangers, evaporators, transport pipes and scrubbers etc.

Specifications

Classifications	SFA/AWS A5.14 : ERNiFeCr-1 EN ISO 18274 : S Ni 8065 (NiFe30Cr21Mo3)
Alloy Type	Nickel alloy (22% Fe, 22% Cr, 3% Mo)
Shielding Gas	I1, I3, M12 (EN ISO 14175)

Typical Tensile Properties

Condition	Yield Strength	Tensile Strength	Elongation
As Welded	355 MPa	560 MPa	47 %

Typical Charpy V-Notch Properties

Condition	Testing Temperature	Impact Value
As Welded	20 °C	220 J
As Welded	-10 °C	215 J
As Welded	-196 °C	190 J

Typical Weld Metal Analysis %

C	Mn	Si	S	P	Ni	Cr	Mo	Al	Cu
0.02	0.6	0.3	0.001	0.016	42	22.4	2.9	0.1	2.2

Typical Weld Metal Analysis %

Ti	PRE	Fe
1	28	24

Typical Wire Composition %

C	Mn	Si	S	P	Ni	Cr	Mo	Al	Cu
0.02	0.6	0.15	0.003	0.01	43.0	22.3	3.0	0.1	1.9

Typical Wire Composition %

Ti	Fe
1	24.4

Recommended Welding Parameters

Wire Diameter	Current	Voltage	Wire Feed Speed
1.2 mm	150-260 A	24-29 V	3.0-10.0 mm/min
1.6 mm	230-350 A	25-30 V	3.0-5.0 mm/min

Exaton Ni53 (GMAW)

Exaton Ni53 is a nickel-chrome-cobalt-molybdenum alloy of type alloy 617. It has an excellent resistance to high temperature corrosion such as oxidation and carburization. The weld metal provides a combination of excellent metallurgical stability and strength in short and long term exposure to temperatures up to 1100°C (2012°F). Applications for Exaton Ni53 are found in high temperature heat exchangers and valves, furnace tubing in the petrochemical industry, radiant heat tubes, gas turbines, components subjected to high temperatures in the chemical processing industry and components for power plants. Exaton Ni53 is suitable for joining heat resistant nickel alloys, heat resistant austenitic and cast alloys such as: – UNS N08810 (1.4958) – UNS N08811 (1.4959) – UNS N06617 (2.4663) Exaton Ni53 can also be used for dissimilar joining of stainless steels to nickel alloys, for overlay welding and it is used for MIG/MAG welding as well as hot wire TIG and mechanical TIG.

Specifications	
Classifications	SFA/AWS A5.14 : ERNiCrCoMo-1 EN ISO 18274 : S Ni 6617 (NiCr22Co12Mo9) Werkstoffnummer : 2.4663

Alloy Type	Alloyed nickel (Ni + 22 % Cr + 8.5 % Mo + 11 % Co)
Shielding Gas	I1, I3 (EN ISO 14175)

Typical Tensile Properties			
Condition	Yield Strength	Tensile Strength	Elongation
As Welded	510 MPa	770 MPa	37 %

Typical Charpy V-Notch Properties		
Condition	Testing Temperature	Impact Value
As Welded	20 °C	130 J
As Welded	-196 °C	105 J

Typical Weld Metal Analysis %									
C	Mn	Si	S	P	Ni	Cr	Mo	Al	Cu
0.07	0.4	0.1	0.002	0.003	53	22	8.5	1.18	0.01

Typical Weld Metal Analysis %			
Ti	Co	B	Fe
0.37	11.0	0.003	1

Typical Wire Composition %									
C	Mn	Si	S	P	Ni	Cr	Mo	Al	Ti
0.07	0.36	0.09	0.001	0.005	54	22.5	8.8	1.3	0.4

Typical Wire Composition %	
Co	Fe
11.3	1

Recommended Welding Parameters			
Wire Diameter	Current	Voltage	Wire Feed Speed
1.0 mm	60-220 A	15-28 V	4.0-12.0 mm/min
1.2 mm	150-260 A	24-29 V	3.0-10.0 mm/min

Exaton Ni54 (GMAW)

Exaton Ni54 is a nickel-chrome-molybdenum alloy of type alloy C-22. It is a versatile alloy with excellent wet corrosion resistance in oxidizing and reducing media. It has better overall corrosion resistance than other Ni-Cr-Mo alloys such as alloy UNS N10276 (2.4819) and alloy UNS N06626 (2.4856). However, in severely reducing media alloy UNS N10276 is preferred where Exaton Ni56 is a better matching consumable. Exaton Ni54 are found in components for organic synthesis, wet chlorine gas, hypochlorite, chlorine dioxide atmosphere and ferric and cupric chloride environments. Typical applications for Exaton Ni54 are geothermal wells, HF furnace scrubbers, pesticide production, flue gas scrubber systems, combustion-resistant components for high pressure oxygen service electrolytic galvanizing, plate heat exchangers, phosphoric acid production phosphoric acid production, SO cooling towers and for weld overlays on valves. Exaton Ni54 is used for joining alloy UNS N06022 (2.4602) and is widely used as overmatching filler material for alloy UNS N10276 (2.4819) and other nickel-chrome-molybdenum alloys for better weld metal properties. Exaton Ni54 can also be used for dissimilar joining of stainless steels to nickel alloys, for overlay welding and it is used for MIG/MAG welding as well as hot wire TIG and mechanical TIG.

Specifications

Classifications	SFA/AWS A5.14 : ERNiCrMo-10 EN ISO 18274 : S Ni 6022 (NiCr21Mo13Fe4W3) Werkstoffnummer : 2.4602
------------------------	---

Alloy Type	Alloyed nickel (Ni + 21.5 % Cr + 13.5 % Mo + 3 % W + 4.5 % Fe)
Shielding Gas	I1, I3 (EN ISO 14175)

Typical Tensile Properties

Condition	Yield Strength	Tensile Strength	Elongation
As Welded	500 MPa	750 MPa	44 %

Typical Charpy V-Notch Properties

Condition	Testing Temperature	Impact Value
As Welded	20 °C	160 J
As Welded	-196 °C	110 J

Typical Weld Metal Analysis %

C	Mn	Si	S	P	Ni	Cr	Mo	V	Cu
0.004	0.10	0.05	0.001	0.006	56	21.9	13.6	0.02	0.02

Typical Weld Metal Analysis %

Co	W	Fe
0.01	3.1	4

Typical Wire Composition %

C	Mn	Si	S	P	Ni	Cr	Mo	V	Cu
0.005	0.1	0.05	0.01	0.01	56	21.5	13.5	0.01	0.01

Typical Wire Composition %

Co	Others tot	W	Fe
0.01	0.5	3	4.5

Recommended Welding Parameters

Wire Diameter	Current	Voltage	Wire Feed Speed
1.2 mm	150-260 A	24-29 V	3.0-10.0 mm/min

Exaton Ni55 (GMAW)

Exaton Ni55 is a nickel-chrome-molybdenum alloy of type alloy 686 and is the highest alloyed of all Ni-Cr-Mo alloys. Exaton Ni55 is used for joining nickel alloy such as UNS N06022 (2.4602), UNS N06059 (2.4605), UNS N10276 (2.4819) and super duplex. The material is thermally unstable at temperatures above 1200°C (2192°F) resulting in great risk for intermetallic phases after welding. Exaton Ni55 provides the best corrosion resistance in most applications and is particularly useful for weld overlay surfacing of boiler tubes in waste-to-energy boilers. Also, the material can be used in the petrochemical, chemical, oil and gas and marine industries. Exaton Ni55 can also be used for dissimilar joining of stainless steels to nickel alloys, for overlay welding and it is used for MIG/MAG welding as well as hot wire TIG and mechanical TIG.

Specifications	
Classifications	SFA/AWS A5.14 : ERNiCrMo-14 EN ISO 18274 : S Ni6686 (NiCr21Mo16W4)

Alloy Type	Alloyed nickel (Ni + 21.5 % Cr + 16 % Mo + 3.5 % W)
Shielding Gas	11, 13 (EN ISO 14175)

Typical Tensile Properties			
Condition	Yield Strength	Tensile Strength	Elongation
As Welded	565 MPa	815 MPa	45 %

Typical Charpy V-Notch Properties		
Condition	Testing Temperature	Impact Value
As Welded	20 °C	110 J
As Welded	-196 °C	75 J

Typical Weld Metal Analysis %									
C	Mn	Si	S	P	Ni	Cr	Mo	Al	Cu
0.008	0.3	0.04	0.001	0.005	57.7	20.5	15.5	0.24	0.04

Typical Weld Metal Analysis %		
Ti	W	Fe
0.07	3.5	0.5

Typical Wire Composition %									
C	Mn	Si	S	P	Ni	Cr	Mo	Al	Cu
0.004	0.26	0.06	0.001	0.02	58	21.4	16	0.23	0.013

Typical Wire Composition %		
Ti	W	Fe
0.10	3.4	0.3

Recommended Welding Parameters			
Wire Diameter	Current	Voltage	Wire Feed Speed
1.2 mm	150-260 A	24-29 V	3.0-10.0 mm/min

Exaton Ni56 (GMAW)

Exaton Ni56 is a low carbon nickel-chrome-molybdenum alloy of type alloy C-276. It is a versatile alloy with excellent wet corrosion resistance in oxidizing and especially in reducing media. However, in oxidizing chloride containing environments alloy UNS N06022 (2.4602) is preferred where Exaton Ni56 is a better matching welding consumable. Applications for Exaton Ni56 are found in aggressively corrosive media such as chemical processing plants, pollution control, pulp and paper production, waste treatment and for the recovery of sour natural gas. Exaton Ni56 is used for joining and overlay welding with MIG/MAG, plasma and hot wire TIG and mechanized TIG. Typical alloys are UNS N10276 (2.4819) and other nickel-chrome-molybdenum alloys. It can also be used for dissimilar metal joining of nickel alloys, stainless steels and low-alloy steels. Applications for Exaton Ni56 are found in cryogenics, components in pulp and paper plants such as bleaching vessels, flue gas scrubber systems, components in sour-gas service, sulphuric acid coolers, chlorine gas, hypochlorite and chlorine dioxide atmosphere. Exaton Ni56 is also used in combustion-resistant components for high pressure oxygen service.

Specifications

Classifications	SFA/AWS A5.14 : ERNiCrMo-4 EN ISO 18274 : S Ni 6276 (NiCr15Mo16Fe6W4) Werkstoffnummer : ~2.4819
Approvals	ABS : ER NiCrMo-4

Approvals are based on factory location. Please contact ESAB for more information.

Alloy Type	Alloyed nickel (Ni + 16 % Cr + 16% Mo + 3.7% W + 5.9 % Fe + Low C)
Shielding Gas	I1, I3, M12 (EN ISO 14175)

Typical Tensile Properties

Condition	Yield Strength	Tensile Strength	Elongation
As Welded	500 MPa	735 MPa	43 %

Typical Charpy V-Notch Properties

Condition	Testing Temperature	Impact Value
As Welded	20 °C	170 J
As Welded	-110 °C	150 J
As Welded	-196 °C	140 J

Typical Weld Metal Analysis %

C	Mn	Si	S	P	Ni	Cr	Mo	V	Cu
0.01	0.5	0.04	0.001	0.005	58	16	16	0.02	0.03

Typical Weld Metal Analysis %

Co	W	Fe
0.01	3.6	6

Typical Wire Composition %

C	Mn	Si	S	P	Ni	Cr	Mo	V	Cu
0.007	0.5	0.02	0.002	0.005	58	16	16	0.03	0.02

Typical Wire Composition %

Co	W	Fe
0.02	3.7	5.8

Recommended Welding Parameters

Wire Diameter	Current	Voltage	Wire Feed Speed
0.8 mm	40-120 A	15-19 V	4.0-8.0 mm/min
1.2 mm	150-260 A	24-29 V	3.0-10.0 mm/min

Exaton Ni59 (GMAW)

Exaton Ni59 is a versatile alloy with excellent wet corrosion resistance for the most demanding applications. It combines excellent corrosion resistance in oxidizing and reducing media, has excellent resistance in chloride containing media and to localized corrosion environments. Exaton Ni59 has excellent thermal stability compared to other common nickel alloys and has therefore outstanding resistance to intermetallic precipitation during welding. Applications for Exaton Ni59 are found in aggressive and contaminated corrosive media including scrubbers for flue gas desulfurisation (FGD), chemical process plants and in severe offshore and petrochemical environments. Furthermore, Exaton Ni59 can be used in contaminated mineral acid environments such as sulfuric acid, hydrochloric acid, phosphoric acid, nitric acid etc. Components in sulfuric acid coolers, digesters and bleachers. Chemical, petrochemical, marine, pharmaceutical, energy production and pollution control. Exaton Ni59 is used for joining matching alloys or dissimilar joining to other nickel alloys such as UNS N10276 (2.4819), type UNS N06022 (2.4602), UNS N06625 (2.4856) and N08825 (2.4858). It provides strong, tough, Nb free weld metal for dissimilar welds in super-austenitic and super-duplex/hyper-duplex stainless steel joints or combinations of these with nickel alloys. Exaton Ni59 is used for joining and overlay welding with MIG/MAG, plasma and hot wire TIG and mechanized TIG. Exaton Ni59 is approved in ISO15156/MR0175 (highest test level VII in sour-gas environments).

Specifications	
Classifications	SFA/AWS A5.14 : ERNiCrMo-13 EN ISO 18274 : S Ni 6059 (NiCr23Mo16) Werkstoffnummer : 2.4605
Approvals	VdTÜV : 09184(GTAW) VdTÜV : 09183

Approvals are based on factory location. Please contact ESAB for more information.

Alloy Type	Alloyed nickel (Ni + 23 % Cr + 15.5 % Mo)
Shielding Gas	I1 (EN ISO 14175)

Typical Tensile Properties			
Condition	Yield Strength	Tensile Strength	Elongation
As Welded	470 MPa	760 MPa	48 %

Typical Charpy V-Notch Properties		
Condition	Testing Temperature	Impact Value
As Welded	20 °C	190 J
As Welded	-196 °C	155 J

Typical Wire Composition %									
C	Mn	Si	S	P	Ni	Cr	Mo	V	Al
0.003	0.20	0.02	0.002	0.003	60.6	22.7	15.5	0.14	0.24

Typical Wire Composition %			
Cu	Ti	Co	Fe
0.01	0.01	0.01	0.5

Recommended Welding Parameters			
Wire Diameter	Current	Voltage	Wire Feed Speed
1.2 mm	150-260 A	24-29 V	3.0-10.0 mm/min
1.6 mm	230-350 A	25-30 V	3.0-5.0 mm/min

Exaton Ni60 (GMAW)

Exaton Ni60 welding wire is suitable for joining nickel-chromium-molybdenum nickel alloys and chromiumnickel-molybdenum steels with very high corrosion resistance in oxidizing, aqueous and high temperature environments such as 6Mo-steels, UNS N06625 (2.4856) and corresponding grades. It is also suitable for joining stainless steels and nickel alloys for high-temperature service. Exaton Ni60 can also be used for dissimilar joining of stainless steels to nickel alloys, for overlay welding with MIG/MAG, plasma and hot wire TIG and mechanized TIG. Applications for Exaton Ni60 are found in cryogenics, components subject to high temperature service up to 980°C (1800°F) such as aircraft ducting, engine exhaust systems, power boilers and recovery boilers and a diversity of seawater applications. The combination of strength and corrosion resistance over a wide range of temperatures is utilized in reaction vessels, line pipe distillation columns and heat exchangers.

Specifications	
Classifications	SFA/AWS A5.14 : ERNiCrMo-3 EN ISO 18274 : S Ni 6625 (NiCr22Mo9Nb) Werkstoffnummer : 2.4831
Approvals	BV : ERNiCrMo-3(GTAW) VdTÜV : 19478(GTAW) VdTÜV : 19483

Approvals are based on factory location. Please contact ESAB for more information.

Alloy Type	Alloyed nickel (Ni + 22 % Cr + 9 % Mo - 3.5 % Nb)
Shielding Gas	I1, I3, M12 (EN ISO 14175)

Typical Tensile Properties			
Condition	Yield Strength	Tensile Strength	Elongation
As Welded	500 MPa	760 MPa	47 %
PWHT 550 °C	360 MPa	590 MPa	49 %

Typical Charpy V-Notch Properties		
Condition	Testing Temperature	Impact Value
As Welded	20 °C	200 J
As Welded	-40 °C	170 J
As Welded	-196 °C	140 J

Typical Weld Metal Analysis %									
C	Mn	Si	S	P	Ni	Cr	Mo	Al	Cu
0.02	0.05	0.07	0.001	0.003	64	21.7	8.7	0.08	0.01

Typical Weld Metal Analysis %				
Nb	Ti	Co	Fe	Nb+Ta
3.35	0.2	0.01	1.48	3.36

Typical Wire Composition %									
C	Mn	Si	S	P	Ni	Cr	Mo	Al	Cu
0.02	0.02	0.06	0.002	0.002	65.0	22	9	0.08	0.02

Typical Wire Composition %					
N	Nb	Ti	Co	Fe	Nb+Ta
0.02	3.4	0.2	0.01	0.3	3.5

Exaton Ni60 (GMAW)

Deposition Data				
Diameter	Current	Voltage	Wire Feed Speed	Deposition Rate
1.0 mm	100-200 A	21-27 V	6.0-13.0 m/min	2.5-5.5 kg/h
1.2 mm	160-280 A	24-30 V	6.0-10.0 m/min	3.6-6.0 kg/h
1.6 mm	200-350 A	25-32 V	4.0-8.0 m/min	4.3-8.6 kg/h

Recommended Welding Parameters				
Wire Diameter	Current	Voltage	Wire Feed Speed	
0.8 mm	40-120 A	15-19 V	4.0-8.0 mm/min	
1.0 mm	60-220 A	15-28 V	4.0-12.0 mm/min	
1.2 mm	150-260 A	24-29 V	3.0-10.0 mm/min	
1.6 mm	230-350 A	25-30 V	3.0-5.0 mm/min	

Exaton Ni60 Overlay

The welding wire of Exaton Ni60 Overlay is especially suitable for overlay welding on non- and low alloyed steels using either hot wire TIG and mechanized TIG or MIG welding. It can also be used for dissimilar joining of stainless steels to nickel alloys, such as 6Mo-steels to UNS N06625 (2.4856) and corresponding grades. The weld chemistry is very corrosion resistant in oxidizing, aqueous and high temperature environments. Applications for Exaton Ni60 Overlay are found in Oil and gas application such as valves, tubes and flanges. Other applications are cryogenics, components subject to high temperature service up to 980°C (1800°F) such as aircraft ducting, engine exhaust systems, power boilers and recovery boilers and a diversity of seawater applications. The combination of strength and corrosion resistance over a wide range of temperatures is utilized in reaction vessels, line pipe distillation columns and heat exchangers.

Specifications

Classifications	SFA/AWS A5.14 : ERNiCrMo-3 EN ISO 18274 : S Ni 6625 (NiCr22Mo9Nb) Werkstoffnummer : 2.4831
Approvals	BV : 1.0 - 3.2mm DNV : 1.2mm VdTÜV : 20096 VdTÜV : 20116 (GTAW)

Approvals are based on factory location. Please contact ESAB for more information.

Alloy Type	Alloyed nickel (Ni + 22 % Cr + 9 % Mo - 3.5 % Nb)
Shielding Gas	I1, I3, M12 (EN ISO 14175)

Typical Tensile Properties

Condition	Yield Strength	Tensile Strength	Elongation
SHT 0.5 hour(s) 1175 °C	375 MPa	765 MPa	46 %
As Welded+	380 MPa	580 MPa	48 %
Stress Relieved 15 hour(s) 550 °C	490 MPa	796 MPa	40 %
SHT+ 0.5 hour(s) 1175 °C	270 MPa	590 MPa	46 %
As Welded	500 MPa	780 MPa	45 %

Typical Charpy V-Notch Properties

Condition	Testing Temperature	Impact Value
SHT 0.5 hour(s) 1175 °C	20 °C	185 J
Stress Relieved 15 hour(s) 550 °C	20 °C	140 J
As Welded	20 °C	130 J
SHT 0.5 hour(s) 1175 °C	-105 °C	170 J
As Welded	-105 °C	120 J
SHT 0.5 hour(s) 1175 °C	-196 °C	150 J
Stress Relieved 15 hour(s) 550 °C	-196 °C	120 J
As Welded	-196 °C	110 J

Typical Weld Metal Analysis %

C	Mn	Si	S	P	Ni	Cr	Mo	Al	Cu
0.02	0.05	0.07	0.001	0.003	64	21.7	8.7	0.08	0.01

Exaton Ni72HP (GMAW)

Exaton Ni72HP is filler material for joining NiCrFe alloys; - UNS N06600, UNS N06601, UNS N06690, UNS N08810 and UNS N08330. - 9% Ni steels used at cryogenic temperatures - stainless steels to carbon steels - high service temperature NiCu alloys to carbon steels and - NiCu alloys to nickel alloys - dissimilar joining of stainless steels to nickel alloys Exaton Ni72HP can be used in air up to 1175°C (2145°F) and in sulphur dioxide atmospheres up to 800°C (1470°F). The alloy is used for overlay welding with MIG/MAG, plasma and hot wire TIG and mechanized TIG.

Specifications	
Classifications	SFA/AWS A5.14 : ERNiCr-3 EN ISO 18274 : S Ni 6082 (NiCr20Mn3Nb)
Approvals	VdTÜV : 00073 VdTÜV : 00515(GTAW)

Approvals are based on factory location. Please contact ESAB for more information.

Alloy Type	Alloyed nickel (Ni + 20 % Cr + 3 % Mn + 2.5 % Nb)
Shielding Gas	11, I3 (EN ISO 14175)

Typical Tensile Properties			
Condition	Yield Strength	Tensile Strength	Elongation
As Welded	420 MPa	660 MPa	35 %

Typical Weld Metal Analysis %									
C	Mn	Si	S	P	Ni	Cr	Mo	Al	Cu
<0.02	3.2	0.01	0.003	<0.003	73	20	0.01	0.09	0.01

Typical Weld Metal Analysis %					
N	Nb	Ti	Co	Fe	Nb+Ta
0.03	2.2	0.31	<0.02	1	2.5

Typical Wire Composition %									
C	Mn	Si	S	P	Ni	Cr	Mo	Al	Cu
<=0.03	3	0.1	<=0.01	<=0.01	73	20.0	0.05	0.4	<=0.05

Typical Wire Composition %					
N	Nb	Ti	Co	Fe	Nb+Ta
<=0.05	2.5	0.4	<=0,1	<=1	2.6

Recommended Welding Parameters			
Wire Diameter	Current	Voltage	Wire Feed Speed
0.8 mm	40-120 A	15-19 V	4.0-8.0 mm/min
1.0 mm	60-220 A	15-28 V	4.0-12.0 mm/min
1.2 mm	150-260 A	24-29 V	3.0-10.0 mm/min
1.6 mm	230-350 A	25-30 V	3.0-5.0 mm/min

Exaton Ni41Cu (GTAW)

Exaton Ni41Cu welding wire is suitable for overlay welding when a deposit with chemistry corresponding to UNS N08825 is required, i.e nickel-iron-chromium-molybdenum-copper. Exaton Ni41Cu has very good resistance to stress corrosion cracking (SCC) in chloride containing environments and is particularly suited for use in reducing environments such as those containing sulphuric and phosphoric acids. Exaton Ni41Cu is used for corrosion resistant alloy surfacing of components in the chemical, pollution control, oil & gas and petrochemical industries and often in connection with sour gas service, typically tanks, heat exchangers, evaporators, transport pipes and scrubbers.

Specifications

Classifications	SFA/AWS A5.14 : ERNiFeCr-1 EN ISO 18274 : S Ni 8065 (NiFe30Cr21Mo3)
------------------------	--

Alloy Type	Alloyed nickel (Ni + 22% Fe, 27% Cr, 3% Mo)
Shielding Gas	I1, I3 (EN ISO 14175)

Typical Tensile Properties

Condition	Yield Strength	Tensile Strength	Elongation
ISO			
As Welded	338 MPa	550 MPa	47 %

Typical Charpy V-Notch Properties

Condition	Testing Temperature	Impact Value
ISO		
As Welded	-196 °C	190 J

Typical Weld Metal Analysis %

C	Mn	Si	S	P	Ni	Cr	Mo	Al	Cu
0.02	0.6	0.3	0.001	0.016	42	22.4	2.9	0.1	2.2

Typical Weld Metal Analysis %

Ti	PRE	Fe
1	28	24

Typical Wire Composition %

C	Mn	Si	S	P	Ni	Cr	Mo	Cu	Ti
0.02	0.8	0.15	0.003	0.01	43.0	22.0	3.0	1.9	1.0

Typical Wire Composition %

Fe
24.4

Exaton Ni53 (GTAW)

Exaton Ni53 is a nickel-chrome-cobalt-molybdenum alloy of type alloy 617. It has an excellent resistance to high temperature corrosion such as oxidation and carburization. The weld metal provides a combination of excellent metallurgical stability and strength in short and long term exposure to temperatures up to 1100°C (2012°F). Applications for Exaton Ni53 are found in high temperature heat exchangers and valves, furnace tubing in the petrochemical industry, radiant heat tubes, gas turbines, components subjected to high temperatures in the chemical processing industry and components for power plants. Exaton Ni53 is suitable for joining heat resistant nickel alloys, heat resistant austenitic and cast alloys such as: – UNS N08810 (1.4958) – UNS N08811 (1.4959) – UNS N06617 (2.4663) Exaton Ni53 can also be used for dissimilar joining of stainless steels to nickel alloys and for overlay welding.

Specifications	
Classifications	SFA/AWS A5.14 : ERNiCrCoMo-1 EN ISO 18274 : S Ni 6617 (NiCr22Co12Mo9) Werkstoffnummer : 2.4663

Alloy Type	Alloyed nickel (Ni + 22 % Cr + 8.5 % Mo + 11 % Co)
Shielding Gas	I1, I3 (EN ISO 14175)

Typical Tensile Properties			
Condition	Yield Strength	Tensile Strength	Elongation
As Welded	510 MPa	770 MPa	37 %

Typical Charpy V-Notch Properties		
Condition	Testing Temperature	Impact Value
As Welded	20 °C	130 J
As Welded	-196 °C	105 J

Typical Weld Metal Analysis %									
C	Mn	Si	S	P	Ni	Cr	Mo	Al	Cu
As Welded									
0.07	0.4	0.1	0.002	0.003	53	22	8.5	1.18	0.01

Typical Weld Metal Analysis %			
Ti	Co	B	Fe
As Welded			
0.37	11.0	0.003	1

Typical Wire Composition %									
C	Mn	Si	S	P	Ni	Cr	Mo	Al	Ti
0.07	0.36	0.09	0.001	0.005	54	22.5	8.8	1.3	0.4

Typical Wire Composition %	
Co	Fe
11.3	1

Exaton Ni54 (GTAW)

Exaton Ni54 is a nickel-chrome-molybdenum alloy of type alloy C-22. It is a versatile alloy with excellent wet corrosion resistance in oxidizing and reducing media. It has better overall corrosion resistance than other Ni-Cr-Mo alloys such as alloy UNS N10276 (2.4819) and alloy UNS N06626 (2.4856). However, in severely reducing media alloy UNS N10276 is preferred where Exaton Ni56 is a better matching consumable. Exaton Ni54 are found in components for organic synthesis, wet chlorine gas, hypochlorite, chlorine dioxide atmosphere and ferric and cupric chloride environments. Typical applications for Exaton Ni54 are geothermal wells, HF furnace scrubbers, pesticide production, flue gas scrubber systems, combustion-resistant components for high pressure oxygen service electrolytic galvanizing, plate heat exchangers, phosphoric acid production phosphoric acid production, SO cooling towers and for weld overlays on valves. Exaton Ni54 is used for joining alloy UNS N06022 (2.4602) and is widely used as overmatching filler material for alloy UNS N10276 (2.4819) and other nickel-chrome-molybdenum alloys for better weld metal properties. Exaton Ni54 can also be used for dissimilar joining of stainless steels to nickel alloys.

Specifications

Classifications

SFA/AWS A5.14 : ERNiCrMo-10
 EN ISO 18274 : S Ni 6022 (NiCr21Mo13Fe4W3)
 Werkstoffnummer : 2.4602

Alloy Type

Alloyed nickel (Ni + 21.5 % Cr + 13.5 % Mo + 3 % W + 4.5 % Fe)

Shielding Gas

I1, I3 (EN ISO 14175)

Typical Tensile Properties

Condition	Yield Strength	Tensile Strength	Elongation
As Welded	540 MPa	770 MPa	44 %

Typical Charpy V-Notch Properties

Condition	Testing Temperature	Impact Value
As Welded	20 °C	160 J
As Welded	-196 °C	120 J

Typical Weld Metal Analysis %

C	Mn	Si	S	P	Ni	Cr	Mo	V	Cu
0.004	0.10	0.05	0.001	0.006	56	21.9	13.6	0.02	0.02

Typical Weld Metal Analysis %

Co	W	Fe
0.01	3.1	4

Typical Wire Composition %

C	Mn	Si	S	P	Ni	Cr	Mo	V	Cu
0.005	0.1	0.05	0.01	0.01	56	21.5	13.5	0.01	0.01

Typical Wire Composition %

Co	Others tot	W	Fe
0.01	0.5	3	4.5

Exaton Ni55 (GTAW)

Exaton Ni55 is a nickel-chrome-molybdenum alloy of type alloy 686 and is the highest alloyed of all Ni-Cr-Mo alloys. Exaton Ni55 is used for joining nickel alloy such as UNS N06022 (2.4602), UNS N06059 (2.4605), UNS N10276 (2.4819) and super duplex. The material is thermally unstable at temperatures above 1200°C (2192°F) resulting in great risk for intermetallic phases after welding. Exaton Ni55 provides the best corrosion resistance in most applications and is particularly useful for weld overlay surfacing of boiler tubes in waste-to-energy boilers. Also, the material can be used in the petrochemical, chemical, oil and gas and marine industries. Exaton Ni55 can also be used for dissimilar joining of stainless steels to nickel alloys and for overlay welding.

Specifications	
Classifications	SFA/AWS A5.14 : ERNiCrMo-14 EN ISO 18274 : S Ni 6686 (NiCr21Mo16W4)

Alloy Type	Alloyed nickel (Ni + 21.5 % Cr + 16 % Mo + 3.5 % W)
Shielding Gas	I1, I3 (EN ISO 14175)

Typical Tensile Properties			
Condition	Yield Strength	Tensile Strength	Elongation
As Welded	565 MPa	815 MPa	45 %

Typical Charpy V-Notch Properties		
Condition	Testing Temperature	Impact Value
As Welded	20 °C	110 J
As Welded	-196 °C	75 J

Typical Weld Metal Analysis %									
C	Mn	Si	S	P	Ni	Cr	Mo	Al	Cu
0.008	0.3	0.04	0.001	0.005	57.5	20.5	15.5	0.24	0.04

Typical Weld Metal Analysis %		
Ti	W	Fe
0.07	3.5	0.5

Typical Wire Composition %									
C	Mn	Si	S	P	Ni	Cr	Mo	Al	Cu
0.004	0.26	0.06	0.001	0.02	58	21.4	16	0.23	0.013

Typical Wire Composition %		
Ti	W	Fe
0.10	3.4	0.3

Exaton Ni56 (GTAW)

Exaton Ni56 is a low carbon nickel-chrome-molybdenum alloy of type alloy C-276. It is a versatile alloy with excellent wet corrosion resistance in oxidizing and especially in reducing media. However, in oxidizing chloride containing environments alloy UNS N06022 (2.4602) is preferred where Exaton Ni54 is a better matching welding consumable. Applications for Exaton Ni56 are found in aggressively corrosive media such as chemical processing plants, pollution control, pulp and paper production, waste treatment and for the recovery of sour natural gas. Exaton Ni56 is used for joining alloy UNS N10276 (2.4819) and other nickel-chrome-molybdenum alloys. Exaton Ni56 is used for joining and overlay welding with TIG. It can also be used for dissimilar metal joining of nickel alloys, stainless steels and low-alloy steels. Applications for Exaton Ni56 are found in cryogenics, components in pulp and paper plants such as bleaching vessels, flue gas scrubber systems, components in sour-gas service, sulphuric acid coolers, chlorine gas, hypochlorite and chlorine dioxide atmosphere. Exaton Ni56 is also used in combustion-resistant components for high pressure oxygen service.

Specifications

Classifications	SFA/AWS A5.14 : ERNiCrMo-4 EN ISO 18274 : S Ni 6276 (NiCr15Mo16Fe6W4) Werkstoffnummer : ~2.4819
Approvals	ABS : ER NiCrMo-4

Approvals are based on factory location. Please contact ESAB for more information.

Alloy Type	Alloyed nickel (Ni + 16 % Cr + 16% Mo + 3.7% W + 5.9 % Fe + Low C)
Shielding Gas	I1 (EN ISO 14175)

Typical Tensile Properties

Condition	Yield Strength	Tensile Strength	Elongation
As Welded	540 MPa	780 MPa	44 %

Typical Charpy V-Notch Properties

Condition	Testing Temperature	Impact Value
As Welded	20 °C	240 J
As Welded	-110 °C	150 J
As Welded	-196 °C	200 J

Typical Weld Metal Analysis %

C	Mn	Si	S	P	Ni	Cr	Mo	V	Cu
0.01	0.5	0.04	0.001	0.006	58	16	16	0.02	0.05

Typical Weld Metal Analysis %

Co	W	Fe
0.02	3.7	6

Typical Wire Composition %

C	Mn	Si	S	P	Ni	Cr	Mo	V	Cu
0.007	0.5	0.02	0.002	0.005	58	16	16	0.03	0.02

Typical Wire Composition %

Co	W	Fe
0.02	3.7	5.8

Exaton Ni59 (GTAW)

Exaton Ni59 is a nickel-chrome-molybdenum alloy of type alloy 59. It is a versatile alloy with excellent wet corrosion resistance for the most demanding applications. It combines excellent corrosion resistance in oxidizing and reducing media, has excellent resistance in chloride containing media and to localized corrosion environments. Exaton Ni59 has excellent thermal stability compared to other common nickel alloys and has therefore outstanding resistance to intermetallic precipitation during welding. Applications for Exaton Ni59 are found in aggressive and contaminated corrosive media including scrubbers for flue gas desulfurisation (FGD), chemical process plants and in severe offshore and petrochemical environments. Furthermore, Exaton Ni59 can be used in contaminated mineral acid environments such as sulfuric acid, hydrochloric acid, phosphoric acid, nitric acid etc. Components in sulfuric acid coolers, digesters and bleachers. Chemical, petrochemical, marine, pharmaceutical, energy production and pollution control. Exaton Ni59 is used for joining matching alloys or dissimilar joining to other nickel alloys such as UNS N10276 (2.4819), type UNS N06022 (2.4602), UNS N06625 (2.4856) and N08825 (2.4858). It provides strong, tough, Nb free weld metal for dissimilar welds in super-austenitic and super-duplex/hyper-duplex stainless steel joints or combinations of these with nickel alloys. Exaton Ni59 is also used for overlay welding and is available as both wire and rod. Exaton Ni59 is approved in ISO15156/MR0175 (highest test level VII in sour-gas environments).

Specifications	
Classifications	SFA/AWS A5.14 : ERNiCrMo-13 EN ISO 18274 : S Ni 6059 (NiCr23Mo16) Werkstoffnummer : 2.4605
Approvals	VdTUV : 09184

Approvals are based on factory location. Please contact ESAB for more information.

Alloy Type	Alloyed nickel (Ni + 23 % Cr + 15.5 % Mo)
Shielding Gas	I1 (EN ISO 14175)

Typical Tensile Properties			
Condition	Yield Strength	Tensile Strength	Elongation
As Welded	540 MPa	780 MPa	42 %

Typical Charpy V-Notch Properties		
Condition	Testing Temperature	Impact Value
As Welded	20 °C	170 J
As Welded	-196 °C	130 J

Typical Wire Composition %									
C	Mn	Si	S	P	Ni	Cr	Mo	V	Al
0.003	0.20	0.02	0.002	0.003	60.6	22.7	15.5	0.14	0.24

Typical Wire Composition %			
Cu	Ti	Co	Fe
0.01	0.01	0.01	0.5

Exaton Ni60 (GTAW)

Exaton Ni60 welding wire is suitable for joining nickel-chromium-molybdenum nickel alloys and chromiumnickel-molybdenum steels with very high corrosion resistance in oxidizing, aqueous and high temperature environments such as 6Mo-steels, UNS N06625 (2.4856) and corresponding grades. It is also suitable for joining stainless steels and nickel alloys for high-temperature service. Exaton Ni60 can also be used for dissimilar joining of stainless steels to nickel alloys, for overlay welding and is available as both wire and rod. Applications for Exaton Ni60 are found in cryogenics, components subject to high temperature service up to 980°C (1800°F) such as aircraft ducting, engine exhaust systems, power boilers and recovery boilers and a diversity of seawater applications. The combination of strength and corrosion resistance over a wide range of temperatures is utilized in reaction vessels, line pipe distillation columns and heat exchangers.

Specifications

Classifications	SFA/AWS A5.14 : ERNiCrMo-3 EN ISO 18274 : S Ni 6625 (NiCr22Mo9Nb) Werkstoffnummer : 2.4831
Approvals	BV : ERNiCrMo-3 VdTÜV : 19478

Approvals are based on factory location. Please contact ESAB for more information.

Alloy Type	Alloyed nickel (Ni + 22 % Cr + 9 % Mo - 3.5 % Nb)
Shielding Gas	I1, I3, R1 (EN ISO 14175)

Typical Tensile Properties

Condition	Yield Strength	Tensile Strength	Elongation
As Welded	540 MPa	780 MPa	47 %

Typical Charpy V-Notch Properties

Condition	Testing Temperature	Impact Value
As Welded	20 °C	170 J
As Welded	-46 °C	150 J
As Welded	-196 °C	140 J

Typical Weld Metal Analysis %

C	Mn	Si	S	P	Ni	Cr	Mo	Al	Cu
0.01	0.03	0.06	0.001	0.003	64	21.9	8.7	0.1	0.01

Typical Weld Metal Analysis %

Ti	Co	Fe	Nb+Ta
0.2	0.02	1.1	3.50

Typical Wire Composition %

C	Mn	Si	S	P	Ni	Cr	Mo	Al	Cu
0.015	0.02	0.05	0.001	0.002	65	22	8.9	0.1	0.01

Typical Wire Composition %

N	Nb	Ti	Co	Fe	Nb+Ta
0.02	3.4	0.2	0.01	0.3	3.5

Exaton Ni72HP (GTAW)

Exaton Ni72HP is filler material for joining NiCrFe alloys; - UNS N06600, UNS N06601, UNS N06690, UNS N08810 and UNS N08330. - 9% Ni steels used at cryogenic temperatures - stainless steels to carbon steels - high service temperature NiCu alloys to carbon steels and - NiCu alloys to nickel alloys - dissimilar joining of stainless steels to nickel alloys Exaton Ni72HP can be used in air up to 1175°C (2145°F) and in sulphur dioxide atmospheres up to 800°C (1470°F). The alloy is used for joining and overlay welding.

Specifications	
Classifications	SFA/AWS A5.14 : ERNiCr-3 EN ISO 18274 : S Ni 6082 (NiCr20Mn3Nb)
Approvals	VdTUV : 00515

Approvals are based on factory location. Please contact ESAB for more information.

Alloy Type	Alloyed nickel (Ni + 20 % Cr + 3 % Mn + 2.5 % Nb)
Shielding Gas	I1, I3 (EN ISO 14175)

Typical Tensile Properties			
Condition	Yield Strength	Tensile Strength	Elongation
As Welded	480 MPa	720 MPa	40 %
As Welded 350 °C	400 MPa	620 MPa	37 %

Typical Charpy V-Notch Properties		
Condition	Testing Temperature	Impact Value
As Welded	20 °C	230 J
As Welded	-196 °C	150 J

Typical Weld Metal Analysis %									
C	Mn	Si	S	P	Ni	Cr	Mo	Al	Cu
<0.02	3.2	0.01	0.003	<0.003	73	20	0.01	0.09	0.01

Typical Weld Metal Analysis %					
N	Nb	Ti	Co	Fe	Nb+Ta
0.03	2.2	0.32	<0.02	1	2.5

Typical Wire Composition %									
C	Mn	Si	S	P	Ni	Cr	Mo	Al	Cu
<=0.03	3	0.1	<=0.01	<=0.01	73	20	0.05	0.4	<=0.05
-	-	-	-	-	-	-	-	-	-

Typical Wire Composition %					
N	Nb	Ti	Co	Fe	Nb+Ta
0.05	2.5	0.4	<=0.1	<=1	2.6
<=0.05	-	-	-	-	-

Cryo-Shield Ni9

Flux cored wire for welding of 9% Ni steel. Cryo-Shield Ni9 is a gas shielded flux cored wire that can be used for welding in all positions using 100% CO₂ shielding gas. This weld metal is a Nickel-based with excellent crack resistance and less sensitive to weld bead surface porosity.

Specifications

Approvals	ABS : Manufacturer's Guarantee BV : Equivalent to N90 CCS : 9Ni DNV-GL : - MS KR : L 91SG(C) LR : 9Ni
------------------	--

Approvals are based on factory location. Please contact ESAB for more information.

Welding Current	DC+
Alloy Type	Ni Cr Mo
Shielding Gas	C1 (EN ISO 14175)

Typical Tensile Properties

Condition	Yield Strength	Tensile Strength	Elongation
C1			
As Welded	440 MPa	730 MPa	44 %

Typical Charpy V-Notch Properties

Condition	Testing Temperature	Impact Value
C1		
As Welded	-196 °C	65 J

Typical Weld Metal Analysis %

C	Mn	Si	S	P	Ni	Cr	Mo	Cu	Ti
CO₂ Shielding gas									
0.02	1.45	0.45	0.002	0.01	58.5	19.0	8.15	0.01	0.12

Typical Weld Metal Analysis %

Fe	Nb+Ta
CO₂ Shielding gas	
9.0	3.00

Deposition Data

Diameter	Current	Voltage	Wire Feed Speed	Deposition Rate
1.2 mm	130-220 A	24-29 V	5.8-14.4 m/min	1.9-4.6 kg/h

Shield-Bright NiCrMo-3

A positional rutile wire for the welding of Ni-Cr-Mo-Nb alloys super stainless steels and 9% Ni steels for cryogenic service. It has <1% Fe for higher corrosion resistance. For use with Ar/15-25%CO₂ shielding gas.

Specifications	
Classifications	AWS A5.34 : ENiCrMo3T1-4 EN ISO 12153 : T Ni 6625 P M21 2

Welding Current	DC+
Alloy Type	Ni-Cr-Mo-Nb
Shielding Gas	M21 (EN ISO 14175)

Typical Tensile Properties			
Condition	Yield Strength	Tensile Strength	Elongation
M21 (Ar/15-25% CO ₂)			
As Welded	501 MPa	788 MPa	42 %

Typical Charpy V-Notch Properties		
Condition	Testing Temperature	Impact Value
M21 (Ar/15-25% CO ₂)		
As Welded	0 °C	75 J
As Welded	-196 °C	70 J

Typical Weld Metal Analysis %									
C	Mn	Si	S	P	Cr	Mo	Cu	Ti	Fe
M21 (Ar/15-25% CO ₂)									
0.02	0.12	0.35	0.003	0.003	21	8.5	0.02	0.1	0.5

Typical Weld Metal Analysis %	
Nb+Ta	
M21 (Ar/15-25% CO ₂)	
3.3	

Deposition Data				
Diameter	Current	Voltage	Wire Feed Speed	Deposition Rate
1.2 mm	130-210 A	23-32 V	5.8-13.8 m/min	1.9-4.2 kg/h

OK Autrod NiCrMo-3

Ni-based solid wire for SAW welding. Corrosion and heat resistant. For welding of high alloyed steels, heat resistant steels, corrosion resistant steels, 9% Ni-steels and similar steels with high toughness at low temperatures. OK Autrod NiCrMo-3 can be combined with OK Flux 10.90, OK Flux 10.93, OK Flux 10.16 or OK Flux 10.17.

Specifications

Classifications	SFA/AWS A5.14 : ERNiCrMo-3 EN ISO 18274 : S Ni 6625 (NiCr22Mo9Nb)
Approvals	VdTÜV : 12101

Approvals are based on factory location. Please contact ESAB for more information.

Alloy Type	NiCrMo-3
-------------------	----------

Typical Wire Composition %

C	Mn	Si	Ni	Cr	Mo	Fe	Nb+Ta
0.02	0.04	0.06	Bal	22.7	8.6	0.3	3.5

OK Autrod NiCrMo-4

OK Autrod NiCrMo-4 is a corrosion and heat resistant, nickel-chromium wire for submerged arc welding of high alloyed steel, heat resistant steel, corrosion resistant steel, 9Ni steels and similar steels with high notch toughness at low temperatures. OK Autrod NiCrMo-4 can be combined with OK Flux 10.99, OK Flux 10.90 or OK Flux 10.16.

Specifications

Classifications

SFA/AWS A5.14 : ERNiCrMo-4
EN ISO 18274 : S Ni 6276 (NiCr15Mo16Fe6W4)

Typical Wire Composition %

C	Mn	Si	Ni	Cr	Mo	W	Fe
0.01	0.45	0.05	Bal.	15.5	16.1	3.5	5.8

OK Flux 10.16

High basic, all mineral, agglomerated flux designed for welding nickel and nickel based alloys. The flux is particularly suitable for strip cladding with Ni-based strip. The silicon transfer from the flux to the weld metal is strongly reduced by the well balanced flux composition and thus minimizing the risk for hot cracking in welding Ni-based alloys.

Specifications	
Classifications	EN ISO 14174 : S A FB 2 55 43 DC
Welding Current	900 A (60 x 0.5 mm strip)
Slag Type	Fluoride basic CaF ₂ -Al ₂ O ₃ -(TiO ₂)-(MnO)
Alloy Transfer	Moderately manganese and silicon alloying
Density	nom: 1.2 kg/dm ³
Basicity Index	nom: 2.4

Classifications	Wire	Weld Metal
Wire	SFA/AWS - EN ISO	AWS - As Welded
OK Autrod NiCrMo-3	A5.14:ERNiCrMo-3 18274:S Ni 6625 (NiCr:22Mo9Nb)	A5.39: F100A32-ERNiCrMo-3/NiCrMo-3
OK Band NiCr3	A5.14:EQNiCrMo-3 18274:B Ni 6625 (NiCr:22Mo9Nb)	-

Typical Weld Metal Analysis %									
C	Mn	Si	S	P	Ni	Cr	Mo	Cu	N
OK Autrod NiCrMo-3 DC+, 350A, 28V, 35cm/min									
0.01	0.6	0.3	0.010	0.01	Bal.	20.7	8.5	0.02	-
OK Band NiCr3 1st layer									
0.02	1.0	0.2	0.01	0.01	Bal	19.0	7.4	-	0.025
OK Band NiCr3 2nd layer									
0.01	1.1	0.2	0.01	0.01	-	21	8.0	-	0.026
OK Band NiCr3 3rd layer									
0.01	1.2	0.2	0.01	0.01	-	20.9	8.4	-	0.027

Typical Weld Metal Analysis %	
Fe	Nb+Ta
OK Autrod NiCrMo-3 DC+, 350A, 28V, 35cm/min	
1.0	3.0
OK Band NiCr3 1st layer	
12.8	2.6
OK Band NiCr3 2nd layer	
4	2.8
OK Band NiCr3 3rd layer	
1.7	2.8

Typical Mechanical Properties					
Wire	Condition	Yield Strength	Tensile Strength	Elongation	Charpy V-Notch
OK Autrod NiCrMo-3	As Welded HI ~1.0-1.7 kJ/mm DC+	450 MPa	720 MPa	50 %	110 J @ -140 °C 100 J @ -196 °C

OK Flux 10.17

High basic, agglomerated flux designed for welding nickel based alloys. The flux is particularly suitable for submerged arc strip cladding with all grades of Ni-based strips. OK Flux 10.17 is new ESAB flux for internal overlay welding on mild or low alloyed steel. It has very good welding characteristics gives a smooth bead appearance and easy slag removal. For chemical and petrochemical plants, offshore constructions, marine equipments, pressure vessels, storage tanks, etc.

Specifications	
Classifications	EN ISO 14174 : S A FB 2B 57 24 DC
Welding Current	900 A (60 x 0.5 mm strip)
Slag Type	Aluminate-fluoride-basic, Al ₂ O ₃ -CaF ₂
Alloy Transfer	Moderately silicon alloying
Density	nom: 1,1 kg/dm ³
Basicity Index	nom: 2,5

Classifications	Wire
Wire	SFA/AWS - EN ISO
OK Autrod NiCrMo-3	A5.14:ERNiCrMo-3 18274:S Ni 6625 (NiCr22Mo9Nb)
OK Band NiCrMo3	A5.14:EQNiCrMo-3 18274:B Ni 6625 (NiCr22Mo9Nb)

Typical Weld Metal Analysis %									
C	Mn	Si	S	P	Ni	Cr	Mo	Cu	Fe
OK Autrod NiCrMo-3 DC+, 300A, 29V, dia 2,4 mm									
0.01	0.1	0.5	0.01	0.01	Bal.	21	8.5	0.08	1
OK Band NiCrMo3 2nd layer									
0.03	0.1	0.6	0.01	0.01	61	19.6	8.0	-	9
OK Band NiCrMo3 3rd layer									
0.02	0.1	0.6	0.01	0.01	64	20.7	8.5	-	3

Typical Weld Metal Analysis %
Nb+Ta
OK Autrod NiCrMo-3 DC+, 300A, 29V, dia 2,4 mm
3.2
OK Band NiCrMo3 2nd layer
2.7
OK Band NiCrMo3 3rd layer
2.9

Typical Mechanical Properties					
Wire	Condition	Yield Strength	Tensile Strength	Elongation	Charpy V-Notch
OK Autrod NiCrMo-3	As Welded HI ~1.0-1.6 kJ/mm DC+	460 MPa	710 MPa	44 %	65 J @ -196 °C

OK Flux 10.90

Agglomerated aluminate-fluoride-basic flux for welding of 9% Ni steels and other high alloyed steels with Ni based wires. The flux is manganese adding, which reduces the risk of hot cracking. Good slag detachability and nice bead appearance.

Specifications

Classifications	EN ISO 14174 : S A AF 2 55 53 MnNi DC
Slag Type	Fluoride basic CaF ₂ -Al ₂ O ₃ -SiO ₂
Alloy Transfer	Chromium compensating. Nickel- and manganese alloying.
Density	nom: 1.0 kg/dm ³
Basicity Index	nom: 1.7

Flux Consumption

Volts	kg Flux / kg Wire DC+
26 V	0.5 kg
30 V	0.6 kg
34 V	0.8 kg
38 V	1.0 kg

Conditions : Dimension 4.0 mm , Amps 580 A , Travel Speed 33 m/h

Classifications	Wire	Weld Metal
Wire	SFA/AWS - EN ISO	AWS - As Welded
OK Autrod 310	A5.9:ER310 14343-A:S 25 20	-
OK Autrod NiCrMo-3	A5.14:ERNiCrMo-3 18274:S Ni 6625 (NiCr22Mo9Nb)	A5.39: F100A32-ERNiCrMo-3/G
OK Autrod NiCrMo-4	A5.14:ERNiCrMo-4 18274:S Ni 6276 (NiCr15Mo16Fe6W4)	A5.39: F100A32-ERNiCrMo-4/G

Approvals

Wire	ABS	BV	CCS	ClassNK	DNV	DNV-GL	KR	RINA
OK Autrod NiCrMo-3	-	-	-	-	-	•	-	-
OK Autrod NiCrMo-4	•	•	•	•	•	-	•	•

Typical Weld Metal Analysis %

C	Mn	Si	S	P	Ni	Cr	Mo	V	Cu
OK Autrod 310									
0.07	3.2	0.40	0.010	0.020	20.5	25.5	0.015	-	0.010
OK Autrod NiCrMo-3 DC+, 350A, 29V									
0.01	1.7	0.2	0.01	0.01	Bal.	21.0	8.5	-	-
OK Autrod NiCrMo-4 DC+, 350A, 29V									
0.01	2.2	0.2	0.03	0.01	Bal.	15.0	15.5	0.04	0.01

Typical Weld Metal Analysis %

Co	W	Fe	Nb+Ta
OK Autrod NiCrMo-3 DC+, 350A, 29V			
-	-	2.0	3.0
OK Autrod NiCrMo-4 DC+, 350A, 29V			
0.15	3.4	6.0	-

OK Flux 10.90

Typical Mechanical Properties					
Wire	Condition	Yield Strength	Tensile Strength	Elongation	Charpy V-Notch
OK Autrod 310	As Welded ISO DC+	390 MPa	570 MPa	34 %	85 J @ 20 °C
OK Autrod NiCrMo-3	As Welded HI ~1.0-1.7 kJ/mm DC+	440 MPa	720 MPa	42 %	100 J @ -196 °C
OK Autrod NiCrMo-4	As Welded DC+	480 MPa	700 MPa	40 %	60 J @ -196 °C

OK Flux 10.93

Basic, agglomerated flux for butt welding of stainless steels. A suitable flux for welding of high alloyed CrNi-steels like e.g. duplex stainless steel. It can also be combined with NiCrMo-3 and NiCrMo-4 wires. The low Si addition during welding provides good mechanical properties in the weld metal.

Specifications	
Classifications	EN ISO 14174 : S A AF 2 56 54 DC
Approvals	CE : EN 13479 DB : 51.039.10 UKCA : EN 13479

Approvals are based on factory location. Please contact ESAB for more information.

Slag Type	Fluoride basic CaF ₂ -Al ₂ O ₃ -SiO ₂
Alloy Transfer	Non alloying
Density	nom: 1.0 kg/dm ³
Basicity Index	nom: 1.9

Flux Consumption	
Volts	kg Flux / kg Wire DC+
26 V	0.5 kg
30 V	0.6 kg
34 V	0.8 kg
38 V	1.0 kg

Conditions : Dimension 4.0 mm , Amps 580 A , Travel Speed 33 m/h

Classifications	Wire	Weld Metal
Wire	SFA/AWS - EN ISO	AWS - As Welded
OK Autrod 16.97	14343-A:S 18 8 Mn	-
OK Autrod 2209	A5.9:ER2209 14343-A:S 22 9 3 N L	-
OK Autrod 2509	A5.9:ER2594 14343-A:S 25 9 4 N L	A5.39: F120A8-ER2594/2594
OK Autrod 308H	A5.9:ER308H 14343-A:S 19 9 H	-
OK Autrod 308L	A5.9:ER308L 14343-A:S 19 9 L	A5.39: F80A32-ER308L/308L
OK Autrod 309L	A5.9:ER309L 14343-A:S 23 12 L	A5.39: F80A10-ER309L/309L
OK Autrod 309MoL	A5.9:ER 23 12 2 L 14343-A:S 23 12 2 L; A5.9:ER309LMo (mod)	A5.39: F85A4-ER309LMo (mod)/309LMo (mod)
OK Autrod 316H	A5.9:ER316H 14343-A:S 19 12 3 H	-
OK Autrod 316L	A5.9:ER316L 14343-A:S 19 12 3 L	A5.39: F75A15-ER316L/316L
OK Autrod 316LMn	A5.9:ER316LMn 14343-A:S 20 16 3 Mn N L	-
OK Autrod 317L	A5.9:ER317L 14343-A:S 18 15 3 L	-
OK Autrod 318	A5.9:ER318 14343-A:S 19 12 3 Nb	-
OK Autrod 347	A5.9:ER347 14343-A:S 19 9 Nb	A5.39: F90A15-ER347/347
OK Autrod 410NiMo	14343-A:S 13 4	-

OK Flux 10.93

Classifications	Wire	Weld Metal
Wire	SFA/AWS - EN ISO	AWS - As Welded
OK Autrod NiCrMo-3	A5.14:ERNiCrMo-3 18274:S Ni 6625 (NiCr22Mo9Nb)	A5.39: F100A32-ERNiCrMo-3/NiCrMo-3
OK Autrod NiCrMo-4	A5.14:ERNiCrMo-4 18274:S Ni 6276 (NiCr15Mo16Fe6W4)	-

Approvals

Wire	ABS	BV	CE	DB	DNV	DNV-GL	LR	UKCA	VdTÜV
OK Autrod 2209	•	•	•	-	-	•	•	•	•
OK Autrod 2509	-	-	•	-	-	-	-	•	•
OK Autrod 308L	•	•	•	•	-	•	-	•	•
OK Autrod 309L	•	-	•	-	-	•	•	•	•
OK Autrod 316L	•	-	•	•	•	-	-	•	•
OK Autrod 318	-	-	•	•	-	-	-	•	•
OK Autrod 347	-	-	•	•	-	-	-	•	•

Typical Weld Metal Analysis %

C	Mn	Si	S	P	Ni	Cr	Mo	V	Cu
OK Autrod 16.97									
0.06	6.3	1.2	0.01	0.02	8.0	18.0	0.1	-	0.1
OK Autrod 2209 Current: DC+, 420A, 27V									
0.02	1.3	0.5	0.01	0.02	9.0	22.5	3.1	-	0.1
OK Autrod 2509 Current: DC+, 350A, 28V, 48cm/min									
0.02	0.4	0.5	0.01	0.02	9.5	24.6	3.5	-	0.2
OK Autrod 308H DC+									
0.05	1.5	0.6	0.01	0.02	9.9	19.9	0.1	-	0.1
OK Autrod 308L Current: DC+, 400A, 28V, 56cm/min									
0.02	1.6	0.5	0.01	0.02	10.0	19.5	0.2	-	0.1
OK Autrod 309L Current: DC+, 400 A, 28 V, welding speed 48cm/min									
0.02	1.3	0.5	0.01	0.02	12.5	23.0	0.2	-	0.2
OK Autrod 309MoL DC+, 380 A, 28 V, 50cm/min									
0.02	1.2	0.5	0.02	0.02	14.5	20.8	2.8	-	0.1
OK Autrod 316H DC+									
0.04	1.5	0.6	0.01	0.02	11.2	18.4	2.1	-	0.1
OK Autrod 316L Current: DC+, 350A, 28V, 48cm/min									
0.02	1.4	0.5	0.01	0.02	12.5	18.0	2.6	-	0.1
OK Autrod 316LMn									
0.02	5.4	0.7	0.01	0.01	15.5	20.0	2.5	-	0.2
OK Autrod 317L Current: DC+, 420 A, 27 V									
0.02	1.5	0.5	0.01	0.02	13.5	18.5	3.2	-	0.1
OK Autrod 318 Current: DC+, 440A, 30V									
0.035	1.2	0.5	0.01	0.02	12.0	18.5	2.6	-	0.2
OK Autrod 347 Current: DC+, 420A, 27V, welding speed 48cm/min									
0.035	1.1	0.5	0.01	0.02	9.6	19.2	0.1	-	0.2
OK Autrod 410NiMo DC+, 450A, 28V									
0.02	0.4	0.5	0.01	0.02	4.1	11.7	0.51	-	0.10
OK Autrod NiCrMo-3 Current: DC+, 400A, 28V, travel speed: 25 m/h.									

OK Flux 10.93

Typical Weld Metal Analysis %

C	Mn	Si	S	P	Ni	Cr	Mo	V	Cu
0.01	0.2	0.4	0.005	0.015	64	21.5	9	-	0.1
OK Autrod NiCrMo-4 DC+, 350A, 28V, 40cm/min									
0.01	0.4	0.20	0.002	0.006	Bal	15.1	15.6	0.1	0.03

Typical Weld Metal Analysis %

N	Nb	Co	FN WRC-92	W	Fe	Nb+Ta
OK Autrod 2209 Current: DC+, 420A, 27V						
0.17	-	-	45	-	-	-
OK Autrod 2509 Current: DC+, 350A, 28V, 48cm/min						
0.20	-	-	58	<0.002	-	-
OK Autrod 308L Current: DC+, 400A, 28V, 56cm/min						
0.06	-	-	9	-	-	-
OK Autrod 309L Current: DC+, 400 A, 28 V, welding speed 48cm/min						
-	-	-	8	-	-	-
OK Autrod 316L Current: DC+, 350A, 28V, 48cm/min						
0.047	-	-	9	-	-	-
OK Autrod 316LMn						
0.13	-	-	-	-	-	-
OK Autrod 318 Current: DC+, 440A, 30V						
-	0.3	-	9	-	-	-
OK Autrod 347 Current: DC+, 420A, 27V, welding speed 48cm/min						
-	0.5	-	8	-	-	-
OK Autrod NiCrMo-3 Current: DC+, 400A, 28V, travel speed: 25 m/h.						
-	-	0.05	-	-	5	3.3
OK Autrod NiCrMo-4 DC+, 350A, 28V, 40cm/min						
-	-	0.1	-	3.6	5.8	-

Typical Mechanical Properties

Wire	Condition	Yield Strength	Tensile Strength	Elongation	Charpy V-Notch
OK Autrod 16.97	As Welded DC+	400 MPa	600 MPa	45 %	60 J @ -20 °C
OK Autrod 2209	As Welded	630 MPa	780 MPa	30 %	140 J @ 20 °C 125 J @ -20 °C 110 J @ -40 °C 80 J @ -60 °C 28 J @ -110 °C
OK Autrod 2509	As Welded DC+	670 MPa	870 MPa	24 %	65 J @ 20 °C 40 J @ -60 °C
OK Autrod 308L	As Welded DC+	400 MPa	570 MPa	40 %	47 J @ -196 °C 100 J @ 20 °C 75 J @ -40 °C 65 J @ -60 °C 55 J @ -110 °C
OK Autrod 309L	As Welded DC+	430 MPa	570 MPa	33 %	90 J @ 20 °C 70 J @ -60 °C 60 J @ -110 °C 25 J @ -196 °C
OK Autrod 309MoL	As Welded DC+	430 MPa	610 MPa	31 %	50 J @ 20 °C 35 J @ -40 °C

OK Flux 10.93

Typical Mechanical Properties

Wire	Condition	Yield Strength	Tensile Strength	Elongation	Charpy V-Notch
OK Autrod 316H	As Welded AWS 475A; 30V; H.I 2.0 kJ /mm DC+	410 MPa	550 MPa	40 %	85 J @ 20 °C 75 J @ 0 °C
OK Autrod 316L	As Welded DC+	420 MPa	550 MPa	42 %	100 J @ 20 °C 65 J @ -60 °C 52 J @ -110 °C 27 J @ -196 °C
OK Autrod 316LMn	As Welded 420A, 30V, 30m/h DC+	410 MPa	600 MPa	30 %	70 J @ -60 °C 60 J @ -110 °C 40 J @ -196 °C
OK Autrod 317L	As Welded DC+	440 MPa	615 MPa	28 %	80 J @ 20 °C 50 J @ -60 °C
OK Autrod 318	As Welded DC+	440 MPa	600 MPa	40 %	100 J @ 20 °C 90 J @ -60 °C 40 J @ -110 °C
OK Autrod 347	As Welded DC+	455 MPa	635 MPa	36 %	90 J @ 20 °C 85 J @ -60 °C 38 J @ -110 °C 25 J @ -196 °C
OK Autrod 410NiMo	As Welded DC+, 450A, 28V	900 MPa	1000 MPa	15.5 %	30 J @ 0 °C 30 J @ -20 °C
OK Autrod 410NiMo	Stress Relieved DC+, 500A, 30V (580 °C 4 hour(s))	785 MPa	860 MPa	18 %	55 J @ 0 °C 50 J @ -20 °C
OK Autrod 410NiMo	Stress Relieved DC+, 450A, 28V (600 °C 2 hour(s))	770 MPa	850 MPa	19 %	55 J @ 0 °C 55 J @ -20 °C
OK Autrod NiCrMo-3	As Welded DC+	450 MPa	710 MPa	45 %	80 J @ -196 °C 90 J @ -60 °C
OK Autrod NiCrMo-4	As Welded DC+	460 MPa	705 MPa	45 %	90 J @ -60 °C 85 J @ -110 °C 75 J @ -196 °C

OK Flux 10.99

OK Flux 10.99 is a neutral agglomerated basic flux designed for the submerged arc welding process of austenitic stainless steels with relevant wires, either using AC or DC+ current. This flux can also be used in both current modes to weld Ni-based alloys with carefully chosen Ni-based wires. Welding in AC usually provides good mechanical properties and better impact properties (when compared to DC+ current). The high basicity of OK Flux 10.99 gives better impact values, regardless of the current being used. It also has very good weldability in 1G and 2G position; the slag is self-lifting or easily detached leaving clean and nice bead appearance.

Specifications	
Classifications	EN ISO 14174 : S A FB 2 55 53 AC
Slag Type	Fluoride basic CaF ₂ - MgO - Al ₂ O ₃
Alloy Transfer	Non alloying
Density	nom: 1.0 kg/dm ³
Basicity Index	nom: 2.1

Flux Consumption		
Volts	kg Flux / kg Wire DC+	kg Flux / kg Wire AC
26 V	0.7 kg	0.6 kg
30 V	0.8 kg	0.8 kg
34 V	0.9 kg	1.1 kg
38 V	1.1 kg	1.3 kg

Conditions : Dimension 3.2 mm , Amps 400 A , Travel Speed 50 cm/min

Classifications	Wire	Weld Metal
Wire	SFA/AWS - EN ISO	AWS - As Welded
OK Autrod 308L	A5.9:ER308L 14343-A:S 19 9 L	-
OK Autrod 309L	A5.9:ER309L 14343-A:S 23 12 L	-
OK Autrod 316L	A5.9:ER316L 14343-A:S 19 12 3 L	-
OK Autrod 316LMn	A5.9:ER316LMn 14343-A:S 20 16 3 Mn N L	-
OK Autrod NiCrMo-4	A5.14:ERNiCrMo-4 18274:S Ni 6276 (NiCr15Mo16Fe6W4)	A5.39: F100A32-ERNiCrMo-4/NiCrMo-4

Approvals				
Wire	BV	CCS	DNV	LR
OK Autrod NiCrMo-4	•	•	•	•

Typical Weld Metal Analysis %									
C	Mn	Si	S	P	Ni	Cr	Mo	V	Cu
OK Autrod 308L AC									
0.025	1.9	0.3	0.01	0.02	9.8	19.2	0.1	-	0.2
OK Autrod 308L DC+									
0.02	1.9	0.3	0.01	0.02	9.8	19.2	0.1	-	0.2
OK Autrod 309L AC									
0.030	1.9	0.4	0.01	0.02	13.0	22.0	0.1	-	0.04
OK Autrod 316L AC									
0.025	1.7	0.4	0.01	0.02	12.0	18.3	2.6	-	0.2
OK Autrod 316LMn									

OK Flux 10.99

Typical Weld Metal Analysis %

C	Mn	Si	S	P	Ni	Cr	Mo	V	Cu
0.03	7.0	0.5	0.01	0.02	16.0	20.0	3.0	-	0.30
OK Autrod NiCrMo-4 AC									
0.015	0.7	0.08	0.002	0.006	Bal	15.2	15.6	0.1	0.1
OK Autrod NiCrMo-4 DC+									
0.01	0.7	0.11	0.002	0.006	Bal	15.2	15.6	0.1	0.1

Typical Weld Metal Analysis %

N	Co	FN WRC-92	W	Fe
OK Autrod 308L AC				
0.07	-	6	-	-
OK Autrod 308L DC+				
0.07	-	6	-	-
OK Autrod 309L AC				
0.09	-	-	-	-
OK Autrod 316L AC				
0.05	-	6	-	-
OK Autrod 316LMn				
0.17	-	-	-	-
OK Autrod NiCrMo-4 AC				
-	0.1	-	3.7	6.5
OK Autrod NiCrMo-4 DC+				
-	0.1	-	3.6	6.5

Typical Mechanical Properties

Wire	Condition	Yield Strength	Tensile Strength	Elongation	Charpy V-Notch
OK Autrod 308L	As Welded AC	400 MPa	560 MPa	36 %	105 J @ -20 °C 100 J @ -40 °C 90 J @ -60 °C 55 J @ -196 °C
OK Autrod 308L	As Welded DC+	400 MPa	560 MPa	36 %	85 J @ -20 °C 80 J @ -40 °C 75 J @ -60 °C 50 J @ -196 °C
OK Autrod 309L	As Welded AC	410 MPa	575 MPa	36 %	105 J @ -20 °C 100 J @ -40 °C 95 J @ -60 °C 85 J @ -110 °C
OK Autrod 316L	As Welded AC	410 MPa	570 MPa	35 %	110 J @ -20 °C 105 J @ -40 °C 100 J @ -60 °C 70 J @ -196 °C
OK Autrod 316LMn	As Welded 400A, 30V, 33m/h AC	420 MPa	630 MPa	40 %	105 J @ -60 °C 90 J @ -110 °C 55 J @ -196 °C
OK Autrod NiCrMo-4	As Welded HI ~0,9-1,1 kJ/mm DC+	480 MPa	720 MPa	42 %	75 J @ -196 °C
OK Autrod NiCrMo-4	As Welded HI ~0,9-1,1 kJ/mm AC	480 MPa	720 MPa	42 %	100 J @ -196 °C

Exaton Ni41Cu (SAW)

Exaton Ni41Cu welding wire is suitable for overlay welding when a deposit with chemistry corresponding to UNS N08825 is required. The weld deposit is a nickel-iron-chromium-molybdenum-copper alloy suitable for use in extremely corrosive environments. Exaton Ni41Cu has very good resistance to stress corrosion cracking (SCC) in chloride containing environments and is particularly suited for use in reducing environments such as those containing sulphuric and phosphoric acids. Exaton Ni41Cu is used for corrosion resistant alloy surfacing of components in the chemical, pollution control, oil & gas and petrochemical industries and often in connection with sour gas service. Typical components are tanks, heat exchangers, evaporators, transport pipes and scrubbers etc. It can be used in combination with 50SW SAW flux.

Specifications

Classifications	SFA/AWS A5.14 : ERNiFeCr-1 EN ISO 18274 : S Ni 8065
------------------------	--

Typical Wire Composition %

C	Mn	Si	S	P	Ni	Cr	Mo	Cu	Fe
<=0.025	1.0	<=0.3	<=0.010	<=0.025	>=42.0	23.0	3.0	2.3	>=22.0

Exaton Ni56 (SAW)

Exaton Ni56 is a low carbon nickel-chrome-molybdenum alloy of type alloy C-276. It is a versatile alloy with excellent wet corrosion resistance in oxidizing and especially in reducing media. However, in oxidizing chloride containing environments alloy UNS N06022 (2.4602) is preferred where Exaton Ni54 is a better matching welding consumable. Applications for Exaton Ni56 are found in aggressively corrosive media such as chemical processing plants, pollution control, pulp and paper production, waste treatment and for the recovery of sour natural gas. Exaton Ni56 is used for joining alloy UNS N10276 (2.4819) and other nickel-chrome-molybdenum alloys. It can also be used for dissimilar metal joining of nickel alloys, stainless steels and low-alloy steels. Exaton Ni56 can be used for surfacing low alloyed steels. Applications for Exaton Ni56 are found in cryogenics, components in pulp and paper plants such as bleaching vessels, flue gas scrubber systems, components in sour-gas service, sulphuric acid coolers, chlorine gas, hypochlorite and chlorine dioxide atmosphere. Exaton Ni56 is also used in combustion-resistant components for high pressure oxygen service It is used for Submerged Arc Welding and recommended flux is Exaton 15W.

Specifications

Classifications	SFA/AWS A5.14 : ERNiCrMo-4 EN ISO 18274 : S Ni 6276 (NiCr15Mo16Fe6W4) Werkstoffnummer : ~2.4819
Alloy Type	Nickel Alloy - 16% Cr - 16% Mo - 5% Fe - 3.5 % W - Low C

Typical Wire Composition %

C	Mn	Si	S	P	Ni	Cr	Mo	V	Cu
0.007	0.5	0.02	0.002	0.005	58	16	16	0.03	0.02

Typical Wire Composition %

Co	W	Fe
0.02	3.7	5.8

Exaton Ni59 (SAW)

Exaton Ni59 is a nickel-chrome-molybdenum alloy of type alloy 59. It is a versatile alloy with excellent wet corrosion resistance for the most demanding applications. It combines excellent corrosion resistance in oxidizing and reducing media, has excellent resistance in chloride containing media and to localized corrosion environments. Exaton Ni59 has excellent thermal stability compared to other common nickel alloys and has therefore outstanding resistance to intermetallic precipitation during welding. Applications for Exaton Ni59 are found in aggressive and contaminated corrosive media including scrubbers for flue gas desulfurisation (FGD), chemical process plants and in severe offshore and petrochemical environments. Exaton Ni59 is used for joining matching alloys or dissimilar joining to other nickel alloys such as UNS N10276 (2.4819), type UNS N06022 (2.4602), UNS N06625 (2.4856) and N08825 (2.4858). It provides strong, tough, Nb free weld metal for dissimilar welds in super-austenitic and super-duplex stainless steel joints or combinations of these with nickel alloys. Exaton Ni59 can be used for surfacing. Applications for Exaton Ni59 are found in contaminated mineral acid environments such as sulfuric acid, hydrochloric acid, phosphoric acid, nitric acid etc. Components in sulfuric acid coolers, digesters and bleachers. Chemical, petrochemical, marine, pharmaceutical, energy production and pollution control. Exaton Ni59 is approved in ISO15156/MR0175 (highest test level VII in sour-gas environments). Exaton Ni59 is used to weld most of the nickel alloys such as alloy 59, C-22, C-276 etc. It can also be used for joining nickel alloys with duplex stainless steels, super duplex stainless steels and hyper duplex stainless steels. It is used for Submerged Arc Welding.

Specifications

Classifications	SFA/AWS A5.14 : ERNiCrMo-13 EN ISO 18274 : S Ni 6059 (NiCr23Mo16) Werkstoffnummer : 2.4605
------------------------	--

Typical Wire Composition %

C	Mn	Si	S	P	Ni	Cr	Mo	V	Al
0.003	0.20	0.02	0.002	0.003	60.6	22.7	15.5	0.14	0.24

Typical Wire Composition %

Cu	Ti	Co	Fe
0.01	0.01	0.01	0.5

Exaton Ni60 (SAW)

Exaton Ni60 welding wire is suitable for joining nickel-chromium-molybdenum nickel alloys and chromium-nickel-molybdenum steels with very high corrosion resistance in oxidizing, aqueous and high temperature environments such as 6Mo-steels, UNS N06625 (2.4856) and corresponding grades. It is also suitable for joining stainless steels and nickel alloys for high-temperature service. Exaton Ni60 can also be used for dissimilar joining of stainless steels to nickel alloys and for overlay welding. Applications for Exaton Ni60 are found in cryogenics, components subject to high temperature service up to 980°C (1800°F) such as aircraft ducting, engine exhaust systems, power boilers and recovery boilers and a diversity of seawater applications. The combination of strength and corrosion resistance over a wide range of temperatures is utilized in reaction vessels, line pipe distillation columns and heat exchangers. It is used for Submerged Arc Welding, for example in combination with the flux Exaton 15W.

Specifications	
Classifications	SFA/AWS A5.14 : ERNiCrMo-3 EN ISO 18274 : S Ni 6625 (NiCr22Mo9Nb) Werkstoffnummer : 2.4831
Approvals	VdTUV : 03770

Approvals are based on factory location. Please contact ESAB for more information.

Typical Wire Composition %									
C	Mn	Si	S	P	Ni	Cr	Mo	Al	Cu
0.01	0.02	0.05	0.001	0.002	64.7	22.0	8.9	0.09	0.01

Typical Wire Composition %		
Ti	Fe	Nb+Ta
0.19	0.30	3.43

Exaton Ni72HP (SAW)

Exaton Ni72HP is filler material for joining NiCrFe alloys, 9% Ni steels used at cryogenic temperatures, stainless steels to carbon steels, high service temperature NiCu alloys to carbon steels and NiCu alloys to nickel alloys. Exaton Ni72HP can be used in air up to 1175°C (2145°F) and in sulphur dioxide atmospheres up to 800°C (1470°F). Recommended flux is Exaton 50SW.

Specifications

Classifications	SFA/AWS A5.14 : ERNiCr-3 EN ISO 18274 : S Ni 6082 (NiCr20Mn3Nb)
Approvals	VdTÜV : 03770

Approvals are based on factory location. Please contact ESAB for more information.

Alloy Type	Alloyed nickel (Ni + 20% Cr + 3% Mn + 2.5% Nb)
-------------------	--

Typical Wire Composition %

C	Mn	Si	S	P	Ni	Cr	Mo	Al	Cu
<=0.03	3.0	0.1	<=0.01	<=0.01	73	20.0	<=0.05	0.4	<=0.05

Typical Wire Composition %

N	Nb	Ti	Co	Fe	Nb+Ta
<=0.05	2.5	0.4	<=0.10	<=1	2.6

Exaton 15W

Exaton 15W is a basic welding flux for submerged arc welding giving good slag removal and a fine bead appearance. Its relatively high basicity makes it suitable for joining of austenitic and duplex stainless steel when high impact strength is desired. Due to its low niobium content burn-off it can be used advantageously with stabilized wire electrodes. Exaton 15W is a high performance welding flux in many joining applications in the chemical, petrochemical and oil&gas industry. It is particularly suited for Exaton range of duplex wire electrodes (e.g. 22.8.3.L/25.10.4.L) due to the highly neutral behavior, which ensures an optimal balanced microstructure. Taking the benefit of its features (not limited to nice bead appearance and self slag release only), it can also be used in combination with NiCrMo-3 and NiCrMo-4 wires for several other applications (i.e. both joining and weld overlay).

Specifications	
Classifications	EN ISO 14174 : S A AF 2
Approvals	CE : EN 13479 UKCA : EN 13479

Approvals are based on factory location. Please contact ESAB for more information.

Welding Current	1200 A (Using 60x0.5 mm strip)
Slag Type	Fluoride basic CaF ₂ -Al ₂ O ₃ -SiO ₂
Density	nom: 1.0 Kg/l
Basicity Index	nom: 1.9

Flux Consumption	
Volts	kg Flux / kg Wire DC+
26 V	0.5 kg
30 V	0.6 kg
34 V	0.8 kg
38 V	1.0 kg

Conditions : Dimension 4.0 mm , Amps 580 A , Travel Speed 33 m/h

Classifications	Wire	Weld Metal
Wire	SFA/AWS - EN ISO	AWS - As Welded
Exaton 19.12.3.LCRYO	A5.9:ER316L 14343-A:S (19 12 3 L); 14343-B:SS316L	-
Exaton 19.9.L	A5.9:ER308L 14343-A:S 19 9 L	-
Exaton 20.25.5.LCu	A5.9:ER385 14343-A:S 20 25 5 Cu L	-
Exaton 22.12.HT	14343-A:S 21 10 N	-
Exaton 22.8.3.L	A5.9:ER2209 14343-A:S 22 9 3 N L	A5.39: F115A15-ER2209/2209
Exaton 24.13.LHF	A5.9:ER309L 14343-A:S 23 12 L	-
Exaton 24.13.LNb	A5.9:ER309LNb 14343-A:S 23 12 Nb	-
Exaton 25.10.4.L	A5.9:ER2594 14343-A:S 25 9 4 N L	A5.39: F120A8-ER2594/2594
Exaton 25.22.2.LMn	A5.9:ERG 14343-A:S 25 22 2 N L	-
Exaton 27.31.4.LCu	A5.9:ER383 14343-A:S 27 31 4 Cu L	-
Exaton Ni56	A5.14:ERNiCrMo-4 18274:S Ni 6276 (NiCr15Mo16Fe6W4)	-
Exaton Ni60	A5.14:ERNiCrMo-3 18274:S Ni 6625 (NiCr22Mo9Nb)	-

Exaton 15W

Approvals

Wire	BV	DNV-GL	VdTÜV
Exaton 19.9.L	-	-	•
Exaton 20.25.5.LCu	-	-	•
Exaton 22.8.3.L	•	•	•
Exaton 25.10.4.L	•	•	•

Typical Weld Metal Analysis %

C	Mn	Si	S	P	Ni	Cr	Mo	V	Cu
Exaton 19.12.3.LCRYO									
0.021	1.5	0.5	0.003	0.023	12.8	18	2.3	-	0.07
Exaton 19.9.L									
0.02	1.2	0.6	0.012	0.025	10	19.5	0.15	-	0.1
Exaton 20.25.5.LCu									
0.01	1.4	0.5	-	-	25	19.6	4.5	-	-
Exaton 22.8.3.L Current: DC+, 400A, 28V, 45cm/min									
0.01	1.2	0.01	-	0.02	8.4	22.0	3.0	-	0.12
Exaton 24.13.LNb									
<=0.020	1.2	0.7	<=0.015	<=0.025	12	23.5	-	-	-
Exaton 25.10.4.L Current: DC+, 350A, 28V, 48cm/min									
0.020	0.4	0.5	0.01	0.020	9.0	24.6	3.5	0.05	0.1
Exaton 25.22.2.LMn Current: DC+, 420A, 27V									
0.02	4.0	0.1	-	-	22.0	24.5	2.1	-	0.1
Exaton 27.31.4.LCu									
0.01	1.4	0.4	0.003	0.01	31.3	26.3	3.5	-	1.0
Exaton Ni56 DC+									
0.01	0.4	0.20	-	-	Bal	15.1	15.6	0.1	-
Exaton Ni60 Current: DC+, 400A, 28V, travel speed: 25 m/h.									
0.02	0.2	0.4	0.005	0.015	-	22	9	-	0.1

Typical Weld Metal Analysis %

N	Nb	Ti	Co	PRE	FN WRC-92	W	Fe	Nb+Ta
Exaton 19.12.3.LCRYO								
0.06	-	-	-	-	3	-	-	-
Exaton 19.9.L								
0.05	-	-	0.1	-	6	-	-	-
Exaton 22.8.3.L Current: DC+, 400A, 28V, 45cm/min								
0.14	<0.01	-	-	35	55	-	-	-
Exaton 24.13.LNb								
-	0.7	-	-	-	-	-	-	-
Exaton 25.10.4.L Current: DC+, 350A, 28V, 48cm/min								
0.22	<0.01	<0.001	0.04	42	55	<0.01	-	-
Exaton 25.22.2.LMn Current: DC+, 420A, 27V								
0.12	-	-	-	-	-	-	-	-
Exaton 27.31.4.LCu								
0.06	-	-	-	-	-	-	-	-
Exaton Ni56 DC+								

Exaton 15W

Typical Weld Metal Analysis %

N	Nb	Ti	Co	PRE	FN WRC-92	W	Fe	Nb+Ta
-	-	-	0.1	-	-	3.6	6.8	-
Exaton Ni60 Current: DC+, 400A, 28V, travel speed: 25 m/h.								
-	-	-	-	-	-	-	5	3

Typical Mechanical Properties

Wire	Condition	Yield Strength	Tensile Strength	Elongation	Charpy V-Notch
Exaton 19.12.3.LCRYO	As Welded	415 MPa	560 MPa	34 %	88 J @ -60 °C 70 J @ -110 °C 46 J @ -196 °C
Exaton 19.9.L	As Welded	390 MPa	560 MPa	35 %	90 J @ 20 °C 35 J @ -196 °C
Exaton 20.25.5.LCu	As Welded	345 MPa	550 MPa	40 %	125 J @ 20 °C 100 J @ -196 °C
Exaton 22.12.HT	As Welded	400 MPa	580 MPa	35 %	120 J @ 20 °C
Exaton 22.8.3.L	As Welded	650 MPa	810 MPa	29 %	85 J @ -40 °C 65 J @ -60 °C 29 J @ -110 °C
Exaton 24.13.LHF	As Welded	410 MPa	600 MPa	40 %	140 J @ 20 °C
Exaton 24.13.LNb	As Welded	400 MPa	600 MPa	35 %	90 J @ 20 °C
Exaton 25.10.4.L	As Welded DC+	680 MPa	870 MPa	24 %	70 J @ 20 °C 45 J @ -50 °C 42 J @ -60 °C
Exaton 25.22.2.LMn	As Welded DC+	335 MPa	575 MPa	42 %	120 J @ 20 °C
Exaton 27.31.4.LCu	As Welded	360 MPa	540 MPa	30 %	80 J @ 20 °C 70 J @ -40 °C
Exaton Ni56	As Welded HI 1.6-1.8 kJ/mm DC+	450 MPa	700 MPa	45 %	100 J @ -60 °C 80 J @ -196 °C
Exaton Ni60	As Welded	445 MPa	715 MPa	45 %	93 J @ -60 °C 82 J @ -196 °C

Exaton 50SW

Exaton 50SW is a basic agglomerated flux with low silicon pickup. It gives good slag removal, good tie-ins and a finely rippled surface. It is suitable for welding with either wire or strip electrodes of nickel alloy type. It is particularly suitable for surfacing with Exaton Ni72HP strip electrodes (EQNiCr-3 type). Typical applications for flux Exaton 50SW are found in nuclear and chemical equipment fields. It is also suitable for dissimilar material welding of nickel alloy grades to stainless steel grades.

Specifications	
Classifications	EN ISO 14174 : S A AF 2
Welding Current	900 A (Using 60x0.5 mm strip)
Slag Type	Fluoride basic CaF ₂ -Al ₂ O ₃ -(TiO ₂)-(MnO)
Density	nom: 1.2 Kg/l
Basicity Index	nom: 2.4

Classifications	Wire
Wire	SFA/AWS - EN ISO
Exaton Ni41Cu	A5.14:ERNiFeCr-1 18274:S Ni 8065
Exaton Ni72HP	A5.14:EQNiCr-3 18274:B Ni 6082
Exaton Ni72HP	A5.14:ERNiCr-3 18274:S Ni 6082 (NiCr20Mn3Nb)

Approvals	
Wire	VdTÜV
Exaton Ni72HP	•

Typical Weld Metal Analysis %									
C	Mn	Si	S	P	Ni	Cr	Mo	Cu	N
Exaton Ni41Cu									
<=0.030	0.8	0.3	<=0.010	<=0.02	40.0	21.5	2.8	2.1	-
Exaton Ni72HP									
0.010	3.3	0.50	0.005	0.012	Bal	18.8	0.1	0.02	-
0.01	3.0	0.4	0.005	0.009	72.0	19.6	-	-	-

Typical Weld Metal Analysis %			
Ti	Co	Fe	Nb+Ta
Exaton Ni41Cu			
-	-	30.0	-
Exaton Ni72HP			

Typical Mechanical Properties					
Wire	Condition	Yield Strength	Tensile Strength	Elongation	Charpy V-Notch
Exaton Ni72HP	As Welded	320 MPa	600 MPa	40 %	120 J @ 20 °C 110 J @ -196 °C

OK Band NiCrMo3

OK Band NiCrMo3 is a nickel-based strip for submerged arc and electroslag strip cladding. Together with OK Flux 10.11, OK Flux 10.16 or OK Flux 10.17 it produces a weld overlay with good corrosion resistance and high temperature properties.

Specifications	
Classifications	SFA/AWS A5.14 : ENiCrMo-3 EN ISO 18274 : B Ni 6625 (NiCr22Mo9Nb)
Approvals	VdTÜV : 12102

Approvals are based on factory location. Please contact ESAB for more information.

Typical Wire Composition %							
C	Mn	Si	Ni	Cr	Mo	Fe	Nb+Ta
<0.1	0.3	0.1	58.0	22.0	9.0	2.0	4.0

OK Band NiFeCr1

OK Band NiFeCr1 is a nickel-iron-chromium strip with additions of molybdenum and copper. The weld deposit in combination with OK Flux 10.11 has excellent resistance to both reducing and oxidizing acids, to stresscorrosion cracking, and to localized attack such as pitting and crevice corrosion. The alloy is especially resistant to sulfuric and phosphoric acids.

Specifications

Classifications

SFA/AWS A5.14 : EQNiFeCr-1
EN ISO 18274 : B Ni 8065 (NiFe30Cr21Mo3)

Typical Wire Composition %

C	Mn	Si	Ni	Cr	Mo	Cu	Ti	Fe
0.01	0.78	0.3	42.5	22.5	3.0	2.2	1.0	>22.0

OK Flux 10.11

Very high basic agglomerated flux for electro slag strip cladding. The flux has a low viscosity and is suitable for cladding with Ni base, Co and fully austenitic alloys due to its good wetting behaviour. Also suitable for welding with higher travel speeds.

Specifications	
Classifications	EN ISO 14174 : ES A FB 2B 56 44 DC
Welding Current	approx. 2500 (90 x 0.5 mm strip)
Slag Type	Fluoride basic CaF ₂ -Al ₂ O ₃
Alloy Transfer	Moderately silicon alloying
Density	nom: 1.0 kg/dm ³
Basicity Index	nom: 5.4

Classifications	Wire	Weld Metal
Wire	SFA/AWS - EN ISO	AWS - As Welded
OK Band NiCrMo3	A5.14:EQNiCrMo-3 18274:B Ni 6625 (NiCr22Mo9Nb)	A5.39: ESCLAD2-EQNiCrMo-3/NiCrMo-3 (mod)
OK Band NiFeCr1	A5.14:EQNiFeCr-1 18274:B Ni 8065 (NiFe30Cr21Mo3)	-

Approvals	
Wire	
*Selected production units only. Please contact ESAB for more information. Visit esab.com to download specific flux/wire combination fact sheets for more details.	

Typical Weld Metal Analysis %									
C	Mn	Si	S	P	Ni	Cr	Mo	Al	Cu
OK Band NiCrMo3 Alloy Type 625 (1 layer)									
0.04	0.08	0.50	-	-	Bal.	20.1	8.1	-	0.01
OK Band NiCrMo3 Alloy Type 625 (2 layer)									
0.04	0.05	0.50	-	-	Bal.	20.8	8.4	-	0.01
OK Band NiFeCr1 Alloy type 825 (2nd layer)									
0.017	0.5	0.85	0.001	0.015	39.5	20.5	3.0	0.03	1.9
OK Band NiFeCr1 Alloy type 825 (1st layer)									
0.018	0.5	0.85	0.001	0.015	38.5	20.0	2.9	0.03	1.8

Typical Weld Metal Analysis %		
Ti	Fe	Nb+Ta
OK Band NiCrMo3 Alloy Type 625 (1 layer)		
-	6.0	2.8
OK Band NiCrMo3 Alloy Type 625 (2 layer)		
-	1.9	2.9
OK Band NiFeCr1 Alloy type 825 (2nd layer)		
0.1	28.0	-
OK Band NiFeCr1 Alloy type 825 (1st layer)		
0.1	31.0	-

OK Flux 10.16

High basic, all mineral, agglomerated flux designed for welding nickel and nickel based alloys. The flux is particularly suitable for strip cladding with Ni-based strip. The silicon transfer from the flux to the weld metal is strongly reduced by the well balanced flux composition and thus minimizing the risk for hot cracking in welding Ni-based alloys.

Specifications	
Classifications	EN ISO 14174 : S A FB 2 55 43 DC
Welding Current	900 A (60 x 0.5 mm strip)
Slag Type	Fluoride basic CaF ₂ -Al ₂ O ₃ -(TiO ₂)-(MnO)
Alloy Transfer	Moderately manganese and silicon alloying
Density	nom: 1.2 kg/dm ³
Basicity Index	nom: 2.4

Classifications	Wire	Weld Metal
Wire	SFA/AWS - EN ISO	AWS - As Welded
OK Autrod NiCrMo-3	A5.14:ERNiCrMo-3 18274:S Ni 6625 (NiCr:22Mo9Nb)	A5.39: F100A32-ERNiCrMo-3/NiCrMo-3
OK Band NiCr3	A5.14:EQNiCrMo-3 18274:B Ni 6625 (NiCr:22Mo9Nb)	-

Typical Weld Metal Analysis %									
C	Mn	Si	S	P	Ni	Cr	Mo	Cu	N
OK Autrod NiCrMo-3 DC+, 350A, 28V, 35cm/min									
0.01	0.6	0.3	0.010	0.01	Bal.	20.7	8.5	0.02	-
OK Band NiCr3 1st layer									
0.02	1.0	0.2	0.01	0.01	Bal	19.0	7.4	-	0.025
OK Band NiCr3 2nd layer									
0.01	1.1	0.2	0.01	0.01	-	21	8.0	-	0.026
OK Band NiCr3 3rd layer									
0.01	1.2	0.2	0.01	0.01	-	20.9	8.4	-	0.027

Typical Weld Metal Analysis %	
Fe	Nb+Ta
OK Autrod NiCrMo-3 DC+, 350A, 28V, 35cm/min	
1.0	3.0
OK Band NiCr3 1st layer	
12.8	2.6
OK Band NiCr3 2nd layer	
4	2.8
OK Band NiCr3 3rd layer	
1.7	2.8

Typical Mechanical Properties					
Wire	Condition	Yield Strength	Tensile Strength	Elongation	Charpy V-Notch
OK Autrod NiCrMo-3	As Welded HI ~1.0-1.7 kJ/mm DC+	450 MPa	720 MPa	50 %	110 J @ -140 °C 100 J @ -196 °C

OK Flux 10.17

High basic, agglomerated flux designed for welding nickel based alloys. The flux is particularly suitable for submerged arc strip cladding with all grades of Ni-based strips. OK Flux 10.17 is new ESAB flux for internal overlay welding on mild or low alloyed steel. It has very good welding characteristics gives a smooth bead appearance and easy slag removal. For chemical and petrochemical plants, offshore constructions, marine equipments, pressure vessels, storage tanks, etc.

Specifications	
Classifications	EN ISO 14174 : S A FB 2B 57 24 DC
Welding Current	900 A (60 x 0.5 mm strip)
Slag Type	Aluminate-fluoride-basic, Al ₂ O ₃ -CaF ₂
Alloy Transfer	Moderately silicon alloying
Density	nom: 1,1 kg/dm ³
Basicity Index	nom: 2,5

Classifications	Wire
Wire	SFA/AWS - EN ISO
OK Autrod NiCrMo-3	A5.14:ERNiCrMo-3 18274:S Ni 6625 (NiCr22Mo9Nb)
OK Band NiCrMo3	A5.14:EQNiCrMo-3 18274:B Ni 6625 (NiCr22Mo9Nb)

Typical Weld Metal Analysis %									
C	Mn	Si	S	P	Ni	Cr	Mo	Cu	Fe
OK Autrod NiCrMo-3 DC+, 300A, 29V, dia 2,4 mm									
0.01	0.1	0.5	0.01	0.01	Bal.	21	8.5	0.08	1
OK Band NiCrMo3 2nd layer									
0.03	0.1	0.6	0.01	0.01	61	19.6	8.0	-	9
OK Band NiCrMo3 3rd layer									
0.02	0.1	0.6	0.01	0.01	64	20.7	8.5	-	3

Typical Weld Metal Analysis %	
Nb+Ta	
OK Autrod NiCrMo-3 DC+, 300A, 29V, dia 2,4 mm	
3.2	
OK Band NiCrMo3 2nd layer	
2.7	
OK Band NiCrMo3 3rd layer	
2.9	

Typical Mechanical Properties					
Wire	Condition	Yield Strength	Tensile Strength	Elongation	Charpy V-Notch
OK Autrod NiCrMo-3	As Welded HI ~1.0-1.6 kJ/mm DC+	460 MPa	710 MPa	44 %	65 J @ -196 °C

Exaton Ni41Cu (ESW)

Exaton Ni41Cu is a nickel-iron-chromium strip electrode used for electro-slag welding (ESW) to deposit single layer or second layer corrosion resistant alloy overlays of Ni8065/UNS N08825 composition on carbon- and low alloyed steels using non-alloying flux. The grade has very good resistance to stress corrosion cracking (SCC) in chloride containing environments and is particularly suited for use in reducing environments such as those containing sulphuric and phosphoric acids.

Specifications

Classifications	SFA/AWS A5.14 : EQNiFeCr-1 EN ISO 18274 : B Ni 8065
------------------------	--

Typical Wire Composition %

C	Mn	Si	S	P	Ni	Cr	Mo	Cu	Fe
<=0.025	1.0	0.3	<=0.010	<=0.025	>=42	23	3	2.3	>=22

Exaton Ni56 (ESW)

Exaton Ni56 is a nickel-chromium-molybdenum strip electrode designed for electroslag welding (ESW) to deposit a second layer corrosion resistant alloy of Ni 6276 /UNS N10276 composition on carbon and low alloyed steels. The recommended flux is Exaton 69S; however, Exaton Ni56 can also be used in combination with other fluxes.

Specifications

Classifications	SFA/AWS A5.14 : EQNiCrMo-4 EN ISO 18274 : B Ni6276 (NiCr15Mo16Fe6W4)
------------------------	---

Alloy Type	EQNiCrMo-4
-------------------	------------

Typical Wire Composition %

C	Mn	Si	S	P	Ni	Cr	Mo	V	Cu
<=0.02	0.2	0.05	<0.01	<0.01	>=50	16	16	<0.05	<0.1

Typical Wire Composition %

Co	W	Fe
<0.1	4	5

Exaton Ni60 (ESW)

Exaton Ni60 is a nickel-chromium-molybdenum strip electrode used for electro-slag welding (ESW) to deposit a second layer corrosion resistant alloy of Ni6625 /UNS N06625 composition on carbon- and low alloyed steels. It can also be used as buffer layer before depositing second layers. Due to the low carbon content of the strip Exaton Ni60 is often used for single layer deposits when the required Fe content in the overlay is less than 10%. The grade is characterized by: – Excellent resistance to stress corrosion cracking in chlorides – Very good resistance to pitting and intergranular corrosion

Specifications

Classifications	SFA/AWS A5.14 : EQNiCrMo-3 EN ISO 18274 : B Ni 6625 (NiCr22Mo9Nb)
------------------------	--

Typical Wire Composition %

C	Mn	Si	S	P	Ni	Cr	Mo	Fe	Nb+Ta
<=0.03	0.2	0.2	<=0.010	<=0.015	>=60	22	9	<=1	3.5

Exaton Ni72HP (ESW)

Exaton Ni72HP is a strip electrode used to obtain a ERNiCr-3 (UNS N06600) corrosion resistant overlay weld deposit on C-, CMn- and low-alloy steels using electrosag welding (ESW) with Exaton 69S or submerged arc welding (SAW) with Exaton 50SW flux. Other combinations and conditions are possible.

Specifications

Classifications	SFA/AWS A5.14 : ENiCr-3 EN ISO 18274 : B Ni 6082
------------------------	---

Typical Wire Composition %

C	Mn	Si	S	P	Ni	Cr	Cu	Ti	Fe
<=0.030	3	0.1	<=0.01	<=0.01	72	20	0.01	0.27	0.33

Typical Wire Composition %

Nb+Ta

2.70

Exaton 50SW

Exaton 50SW is a basic agglomerated flux with low silicon pickup. It gives good slag removal, good tie-ins and a finely rippled surface. It is suitable for welding with either wire or strip electrodes of nickel alloy type. It is particularly suitable for surfacing with Exaton Ni72HP strip electrodes (EQNiCr-3 type). Typical applications for flux Exaton 50SW are found in nuclear and chemical equipment fields. It is also suitable for dissimilar material welding of nickel alloy grades to stainless steel grades.

Specifications	
Classifications	EN ISO 14174 : S A AF 2
Welding Current	900 A (Using 60x0.5 mm strip)
Slag Type	Fluoride basic CaF ₂ -Al ₂ O ₃ -(TiO ₂)-(MnO)
Density	nom: 1.2 Kg/l
Basicity Index	nom: 2.4

Classifications	Wire
Wire	SFA/AWS - EN ISO
Exaton Ni41Cu	A5.14:ERNiFeCr-1 18274:S Ni 8065
Exaton Ni72HP	A5.14:EQNiCr-3 18274:B Ni 6082
Exaton Ni72HP	A5.14:ERNiCr-3 18274:S Ni 6082 (NiCr20Mn3Nb)

Approvals	
Wire	VdTÜV
Exaton Ni72HP	•

Typical Weld Metal Analysis %									
C	Mn	Si	S	P	Ni	Cr	Mo	Cu	N
Exaton Ni41Cu									
<=0.030	0.8	0.3	<=0.010	<=0.02	40.0	21.5	2.8	2.1	-
Exaton Ni72HP									
0.010	3.3	0.50	0.005	0.012	Bal	18.8	0.1	0.02	-
0.01	3.0	0.4	0.005	0.009	72.0	19.6	-	-	-

Typical Weld Metal Analysis %			
Ti	Co	Fe	Nb+Ta
Exaton Ni41Cu			
-	-	30.0	-
Exaton Ni72HP			

Typical Mechanical Properties					
Wire	Condition	Yield Strength	Tensile Strength	Elongation	Charpy V-Notch
Exaton Ni72HP	As Welded	320 MPa	600 MPa	40 %	120 J @ 20 °C 110 J @ -196 °C

Exaton 69S

Exaton 69S is a highly basic, agglomerated flux for electroslag strip surfacing. It gives excellent slag removal and bead appearance. Flux Exaton 69S is used together with strip electrodes of nickel alloy type, such as EQNiCr-3, EQNiCrMo-3, EQNiFeCr-1 and ERNiCrFe-7 or similar.

Specifications	
Classifications	EN ISO 14174 : ES A FB 2B
Welding Current	2500 A (Using 60x0.5 mm strip)
Slag Type	Fluoride basic CaF ₂ -Al ₂ O ₃
Density	nom: 1.0 Kg/l
Basicity Index	nom: 5.4

Classifications	Wire	Weld Metal
Wire	SFA/AWS - EN ISO	AWS - As Welded
Exaton Ni41Cu	A5.14:EQNiFeCr-1 18274:B Ni 8065	-
Exaton Ni56	A5.14:EQNiCrMo-4 18274:B Ni6276 (NiCr15Mo16Fe6W4)	A5.39: ESCLAD2-EQNiCrMo-4/NiCrMo-4 (mod)
Exaton Ni60	A5.14:EQNiCrMo-3 18274:B Ni 6625 (NiCr22Mo9Nb)	A5.39: ESCLAD2-EQNiCrMo-3/ NiCrMo-3 (mod)
Exaton Ni72HP	A5.14:EQNiCr-3 18274:B Ni 6082	A5.39: ESCLAD2-EQNiCr-3/NiCr-3

Typical Weld Metal Analysis %									
C	Mn	Si	S	P	Ni	Cr	Mo	V	Cu
Exaton Ni41Cu Alloy type 825 (1 layer)									
0.029	0.57	0.46	-	-	38.5	19.9	2.7	-	1.9
Exaton Ni41Cu Alloy type 825 (2 layer)									
0.021	0.55	0.47	-	-	41.4	21.7	2.8	-	2.1
Exaton Ni56 2 layers									
<0.02	0.1	<0.4	<0.01	<0.02	59	15.6	15.9	<0.05	<0.1
Exaton Ni60 Alloy Type 625 (1 layer)									
0.04	0.07	0.50	-	-	Bal.	20.3	8.2	-	0.01
Exaton Ni60 Alloy Type 625 (2 layer)									
0.02	0.05	0.50	-	-	-	21.0	8.5	-	0.01
Exaton Ni72HP Cladding 2 layers									
0.006	2.8	0.50	0.003	0.006	73	19.5	-	-	0.02

Typical Weld Metal Analysis %						
Nb	Ti	Co	W	Fe	Nb+Ta	
Exaton Ni41Cu Alloy type 825 (1 layer)						
0.01	-	-	-	34	-	
Exaton Ni41Cu Alloy type 825 (2 layer)						
0.01	-	-	-	30	-	
Exaton Ni56 2 layers						
-	-	<0.1	3.8	5	-	
Exaton Ni60 Alloy Type 625 (1 layer)						
-	-	-	-	5.8	2.8	
Exaton Ni60 Alloy Type 625 (2 layer)						
-	-	-	-	0.9	3.0	
Exaton Ni72HP Cladding 2 layers						
-	0.05	<0.15	-	0.60	2.3	

Exaton 79S

Exaton 79S is a newly designed highly basic, agglomerated flux for electroslag strip cladding delivering excellent slag removal and bead appearance. Flux Exaton 79S is recommended for the usage with Nb-bearing strip electrodes of nickel alloy type, such as EQNiCr-3 and EQNiCrMo-3 or similar.

Specifications	
Classifications	EN ISO 14174 : ES A FB 2B DC
Slag Type	Fluoride basic CaF ₂ -Al ₂ O ₃
Density	nom: 1.0 kg/dm ³
Basicity Index	nom: 5.4

Classifications	Wire	Weld Metal
Wire	SFA/AWS - EN ISO	AWS - As Welded
Exaton Ni60	A5.14:EQNiCrMo-3 18274:B Ni 6625 (NiCr22Mo9Nb)	A5.39: ESCLAD1-EQNiCrMo-3/NiCrMo-3 A5.39: ESCLAD2-EQNiCrMo-3/NiCrMo-3
Exaton Ni72HP	A5.14:EQNiCr-3 18274:B Ni 6082	A5.39: ESCLAD1-EQNiCr-3/NiCr-3 A5.39: ESCLAD2-EQNiCr-3/NiCr-3

Typical Weld Metal Analysis %									
C	Mn	Si	S	P	Ni	Cr	Mo	Cu	Ti
Exaton Ni60 1st layer									
0.024	0.05	0.53	0.003	0.006	63	20.2	8.8	0.02	-
Exaton Ni60 2nd layer									
0.019	0.08	0.46	0.003	0.006	Bal.	21.8	9.2	0.05	-
Exaton Ni72HP 2nd layer									
0.010	2.7	0.45	0.01	0.01	72.0	19.0	-	0.02	0.05
Exaton Ni72HP 1st layer									
0.02	2.6	0.50	0.01	0.01	71.0	18.8	-	0.02	0.05

Typical Weld Metal Analysis %	
Fe	Nb+Ta
Exaton Ni60 1st layer	
2.9	3.6
Exaton Ni60 2nd layer	
1.0	3.7
Exaton Ni72HP 2nd layer	
1.7	2.9
Exaton Ni72HP 1st layer	
2.5	2.8



Aluminium



Welding Consumables For Aluminium and Aluminium Alloys..... 6-3

STICK ELECTRODES (SMAW)..... 6-7

OK AlMn1..... 6-7

OK AISi5..... 6-8

OK AISi12..... 6-9

MIG WIRES/TIG RODS (GMAW/GTAW) 6-10

OK Autrod 1070 6-10

OK Autrod 1100 6-11

OK Autrod 1450 6-12

OK Autrod 4043 6-13

OK Autrod 4047 6-14

OK Autrod 5087 6-15

OK Autrod 5183 6-16

OK Autrod 5356 6-17

OK Autrod 5554 6-18

OK Autrod 5556 6-19

OK Tigrod 1070..... 6-20

OK Tigrod 1100..... 6-21

OK Tigrod 1450..... 6-22

OK Tigrod 4043..... 6-23

OK Tigrod 4047..... 6-24

OK Tigrod 5087 6-25

OK Tigrod 5183..... 6-26

OK Tigrod 5356..... 6-27

OK Tigrod 5554..... 6-28

1. Classification and Features of Aluminium Alloys

Aluminium wrought alloys (EN 573 - Part 1 to Part 3) and welding consumables (EN ISO 18273) are now designated using a four-digit numbering system created by the Aluminium Association (AA). However, a new five-digit designation system has been introduced in Europe for cast materials (EN 1706).

Aluminium alloys are divided into:

- Primary aluminium (e.g. EN AW-1070A / EN AW-AI 99.7)
- Work-hardened alloys (e.g. EN AW-5754 / EN AW-AI Mg3 and EN AW-5083 / EN AW-AI Mg4.5Mn0.7)
- Hardenable wrought alloys (e.g. EN AW-6063 / EN AW-AI Mg0.7Si and EN AW-7020 / EN AW-AI Zn4.5Mg1)
- Cast alloys (e.g. EN AC-43000 / EN AC-AI Si10Mg(a) and EN AC-51300 / EN AC-AI Mg5)

Several special features make aluminium alloys a preferred construction material today. Typical characteristics are the low density (approx. 2.7 g/cm³) with high achievable strengths (lightweight construction), good weather and corrosion resistance, very good formability, high thermal conductivity, good electrical conductivity and good cold resistance.

However, some of these features also pose significant obstacles to welding. The natural oxide layer, which spontaneously forms on the surface of parts made of aluminium and aluminium alloys under the influence of atmospheric oxygen, protects the underlying metal against chemical attack by numerous media.

However, the melting point of aluminium oxide is approx. 2050°C, which is significantly higher than the melting point of the pure metal (660°C). This forms a barrier and prevents the melted parent material from flowing together. The disruptive oxide layer must therefore be destroyed and removed before or during welding, which is usually achieved through the cleaning action of the arc (TIG and MIG) or chemically by fluxing agents (soldering, gas welding, metal-arc welding (E)).

The very good thermal conductivity is one of the main factors for the high heat requirement during welding, despite the relatively low melting point of aluminium. In addition, the heat influence on the parent material during welding is correspondingly high. Due to the influence of the welding heat, any increase in strength in the heat-affected zone (HAZ) achieved by cold working or hardening during fusion welding is completely or partially reversed and it reverts to the strength of the fully recrystallised (softened) state. Recrystallization-inhibiting additives in the parent material (Mn, Cr) counteract complete softening. This softening must be taken into account as follows:

- Arrange welds at parts of the structure that are exposed to minimal stress.
- Compensate for the loss in strength by locally increasing the plate thickness.

2. Welding Processes

The most common welding processes are TIG and MIG welding. The oxide layer is removed by the cleaning effect in the arc. TIG welding is usually carried out using alternating current (AC), while MIG welding is carried out using direct current with positive polarity, (DC+). In these processes, argon or argon-helium mixtures are used as protective gases. The advantages of shielding gases with high helium content include a deeper penetration, better bead shape, higher power and lower pore sensitivity, whereas the disadvantages include a higher gas price and higher consumption during welding.

Gas welding, which was previously common, has become less important because it requires the use of special, aggressive fluxes to remove the oxide film, the effectiveness of which decreases with increasing Mg content and the residues of which can cause corrosion. The removal of flux residues is also time-consuming and requires special measures for occupational health and environmental protection. This also applies to MMA welding with coated stick electrodes whose coating contains aggressive salts as flux.

3. Welding Instructions

The joint preparation is prepared by grinding, milling or plasma cutting. Abrasives must not be plastic-bonded and any mechanical cutting must be carried out dry. This is standardised for TIG and MIG welding in EN ISO 9692-3. It is always important to ensure that the included angle for V-groove preparation is 70°, bevel the reverse side with 0.5 mm x 45°. Butt welds without root gap on backing plates made of stainless CrNi steel are common.

For metal thicknesses over 6 mm, a higher heat input or a preheating temperature of 100 - 120°C is required due to the high thermal conductivity of the parent material (at least at the beginning of the weld). The preheating zone and the preheating time should be minimised to prevent damage to the parent material.

Achieving perfect welds requires the utmost cleanliness at the welding point. Here, the joint area must be thoroughly degreased and direct skin contact with the welding rod or wire must be avoided (wear clean gloves).

The high thermal expansion coefficient of aluminium alloys can lead to greater shrink bending of components. Therefore, the smallest possible weld cross-sections should be selected. Stringer bead technique and use of clamping devices counteract excessive shrink bending.

Post-weld treatment of the welds is generally not necessary.

4. Materials and Heterogeneous Joints

AlSi welding consumables (S Al 4xxx) are preferably used for similar Si-containing wrought and cast alloys as well as for mixed joints. OK Autrod / Tigrod 4043 (AlSi5) can be used for alloys with Si \leq 7%, whereas OK Autrod / Tigrod 4047 (AlSi12) is suitable for Si levels above 7%. When processing cast aluminium, the casting process must also be taken into account. As a rule, die-cast parts are not intended for welding, as the dissolved gases lead to severe pore formation. If die-cast parts are to be welded, they must be designed and cast accordingly and their weldability must be demonstrated.

AlMg alloys: as the Mg content increases (Mg \geq 3%), so do the strength values, but the corrosion resistance decreases. Therefore, AlMg materials should always be welded with materials of the same type, i.e. using filler materials with the most closely matching Mg content. The dilution with the parent material must be taken into consideration, since AlMg weld metals with Mg $<$ 2% may be susceptible to hot cracking. When processing AlMg materials, a dark deposit consisting of magnesium oxide appears next to the weld and can be removed by brushing (for aluminium, always use sharp-edged CrNi brushes).

Magnesium alloyed materials with Mg \geq 2% are to be welded with similar welding consumables of type S AlMg (S Al 5xxx), silicon alloyed grades with Si \geq 2% with S AlSi (S Al 4xxx). Use of not similar grades should be avoided due to embrittlement caused by precipitation of Mg₂Si.

Mixed joints between materials with Mg \geq 2% and Si \geq 2% should be avoided under dynamic or shock loading, due to the Mg₂Si precipitations that would lead to embrittlement. If heterogeneous joints are unavoidable, use of OK Autrod / Tigrod 4043 is preferred.

5. Colouring After Welding (Anodizing)

After anodising the surface, the different microstructures or different compositions become visible in the weld area. The colour differences are also influenced by the surface roughness and the layer thickness of the anodizing. However, the protective effect of the anodizing layer is not affected by the differences in colour tone.

In AlSi weld metal, the grey to dark grey discolouration increases together with an increase in Si content.

AlMg welding consumables of type AlMg5 have proven particularly effective for the welding process before anodising:

S Al 5356 (AlMg5Cr(A)):

- OK Tigrod 5356
- OK Autrod 5356

These provide the best possible colour similarity. In order to keep the colour differences between the weld area and the unaffected parent material as small as possible, the component surface should only be ground or brushed as finely as necessary. The rougher the surface, the lower the light reflection and the contrast of the colour differences. The colour of the weld metal after anodizing is indicated on the following product data sheets.

Anodizing layers must be removed before welding.

6. Reference Materials

EN 1011-4:	Recommendations for welding metallic materials – Part 4: Arc welding of aluminium and aluminium alloys.
EN ISO 9692-3:	Recommendations for joint shapes – Part 3: MIG and TIG welding of aluminium and aluminium alloys

OK AIMn1



Covered electrode suitable for welding of Mn-alloyed aluminium and aluminium alloys containing up to 3 % Mg, e.g. EN AW-3103, 3207, 3003, 5005.

Specifications

Classifications	EN ISO 18273 : AIMn1
Welding Current	DC+
Alloy Type	Aluminium alloy AIMn1
Coating Type	Chloride and Fluoride Salt

Typical Weld Metal Analysis %

Mn	Si	Al	Fe
1.3	0.1	98.1	0.3

Deposition Data

Diameter	Current	Voltage	Efficiency (%)	Fusion time per electrode at 90% I max	Deposition Rate
2.4 x 350 mm	50-90 A	25 V	41 %	24 sec	0.51 kg/h
3.2 x 350 mm	70-120 A	21 V	89 %	23 sec	1.74 kg/h

OK AISi5



Covered electrode suitable for welding of AlMgSi-alloys e.g. EN AW 6060/6063, 6005, 6201 etc. Also suitable for welding of AISi5Cu- and AISi7Mg-castings.

Specifications

Classifications	EN ISO 18273 : AISi5
------------------------	----------------------

Welding Current	DC+
Alloy Type	Aluminium-silicon alloy, AISi5
Coating Type	Chloride and Fluoride Salt

Typical Weld Metal Analysis %

Si	Al	Fe
4.9	94.9	0.2

Deposition Data

Diameter	Current	Voltage	Efficiency (%)	Fusion time per electrode at 90% I max	Deposition Rate
2.4 x 350 mm	50-90 A	25 V	37 %	24 sec	0.45 kg/h
3.2 x 350 mm	70-120 A	23 V	47 %	27 sec	0.8 kg/h

OK AISi12



Covered electrode suitable for welding of aluminium castings of AISi-, AISiMg- and AISiCu-types. Also possible to use as filler material in gas welding.

Specifications

Classifications	EN ISO 18273 : AISi12
Welding Current	DC+
Alloy Type	Aluminium-silicon alloy, AISi12
Coating Type	Chloride and Fluoride Salt

Typical Weld Metal Analysis %

Si	Al	Fe
12.4	87.4	0.2

Deposition Data

Diameter	Current	Voltage	Efficiency (%)	Fusion time per electrode at 90% I max	Deposition Rate
2.4 x 350 mm	50-90 A	23 V	42 %	23 sec	0.54 kg/h
3.2 x 350 mm	70-120 A	23 V	45 %	30 sec	0.69 kg/h

OK Autrod 1070

OK Autrod 1070 is highly resistant to chemical attack and weathering. It is a relatively soft alloy that is very formable and is used extensively in thin gauge and foil products. It has good welding characteristics. A desirable characteristic of the alloy is the bright finish obtained by anodising. Non-Heat treatable.

Specifications

Classifications	EN ISO 18273 : S Al 1070 (Al99,7)
------------------------	-----------------------------------

Alloy Type	Al
Shielding Gas	11, 13 (EN ISO 14175)

Typical Tensile Properties

Condition	Yield Strength	Tensile Strength	Elongation
As Welded	35 MPa	75 MPa	45 %

Typical Wire Composition %

Mn	Si	V	Al	Cu	Fe
0.01	0.02	0.01	99.80	0.01	0.13

Recommended Welding Parameters

Wire Diameter	Current	Voltage
1.0 mm	90-275 A	15-26 V
1.2 mm	140-260 A	20-29 V
1.2 mm	140-300 A	20-29 V
1.6 mm	190-350 A	25-30 V
2.0 mm	190-350 A	25-30 V
2.4 mm	280-400 A	26-31 V

OK Autrod 1100

OK Autrod 1100 is highly resistant to chemical attack and weathering. It is a relatively soft alloy that is very formable and is used extensively in thin gauge and foil products. It has good welding characteristics. A desirable characteristic of the alloy is the bright finish obtained by anodising. Non-Heat treatable.

Specifications

Classifications	SFA/AWS A5.10 : ER1100 EN ISO 18273 : S Al 1100 (Al99,0Cu)
Approvals	CWB : AWS A5.10/A5.10M:2012 (ER1100)

Approvals are based on factory location. Please contact ESAB for more information.

Alloy Type	Al
Shielding Gas	I1, I3 (EN 439)

Typical Tensile Properties

Condition	Yield Strength	Tensile Strength	Elongation
As Welded	30 MPa	75 MPa	35 %

Typical Wire Composition %

Cu	Si+Fe	Zn	Be
0.07	0.55	0.01	0.0001

Recommended Welding Parameters

Wire Diameter	Current	Voltage
1.0 mm	140-260 A	20-29 V
1.0 mm	140-300 A	20-29 V
1.2 mm	140-260 A	20-29 V
1.2 mm	180-210 A	22-26 V
1.2 mm	125-150 A	20-24 V
1.2 mm	170-240 A	24-28 V
1.2 mm	140-300 A	20-29 V
1.6 mm	190-350 A	25-30 V
1.6 mm	240-300 A	22-27 V
1.6 mm	190-260 A	21-26 V
1.6 mm	280-320 A	24-28 V
1.6 mm	260-310 A	22-27 V
1.6 mm	290-340 A	26-30 V

Autrod 1450

Autrod 1450 is highly resistant to chemical attack and weathering. The alloy has a small addition of titanium, which has a grainrefining effect, which reduces the cracking susceptibility. It has good welding characteristics. A desirable characteristic of the alloy is the bright finishes obtained by anodising. Non Heat treatable.

Specifications

Classifications	EN ISO 18273 : S Al 1450 (Al99,5Ti)
------------------------	-------------------------------------

Alloy Type	Al
Shielding Gas	11, 13 (EN ISO 14175)

Typical Tensile Properties

Condition	Yield Strength	Tensile Strength	Elongation
As Welded	40 MPa	90 MPa	35 %

Typical Wire Composition %

Mn	Si	Al	Cu	Ti	Zn	Fe
0.02	0.02	99.8	0.01	0.12	0.01	0.16

Recommended Welding Parameters

Wire Diameter	Current	Voltage
1.2 mm	140-260 A	20-29 V
1.6 mm	190-350 A	25-30 V

OK Autrod 4043

OK Autrod 4043 is one of the most widely used welding and brazing alloys and can be classed as a general purpose filler alloy. The silicon additions result in improved fluidity (wetting action) to make the alloy a preferred choice by welders. The alloy is not sensitive to weld cracking and produces bright and almost smut free welds. Not recommended for anodizing. Non-Heat treatable.

Specifications	
Classifications	SFA/AWS A5.10 : ER4043 EN ISO 18273 : S Al 4043 (AlSi5)
Approvals	CE : EN 13479 CWB : ER4043 DB : 61.039.05 UKCA : EN 13479 VdTÜV : 12187

Approvals are based on factory location. Please contact ESAB for more information.

Alloy Type	AlSi
Shielding Gas	11, 13 (EN ISO 14175)

Typical Tensile Properties			
Condition	Yield Strength	Tensile Strength	Elongation
As Welded	85 MPa	185 MPa	18 %

Typical Wire Composition %						
Mn	Si	Al	Cu	Ti	Zn	Fe
0.01	5.00	Rem	0.02	0.01	0.01	0.14

Recommended Welding Parameters		
Wire Diameter	Current	Voltage
0.8 mm	60-170 A	13-24 V
0.8 mm	100-130 A	18-22 V
0.8 mm	125-150 A	20-24 V
0.9 mm	60-170 A	13-24 V
0.9 mm	125-150 A	20-24 V
0.9 mm	85-120 A	20-23 V
0.9 mm	170-190 A	21-26 V
1.0 mm	90-275 A	15-26 V
1.2 mm	140-260 A	20-29 V
1.2 mm	170-240 A	24-28 V
1.2 mm	125-150 A	20-24 V
1.2 mm	180-210 A	22-26 V
1.2 mm	140-300 A	20-29 V
1.6 mm	190-350 A	25-30 V
1.6 mm	190-260 A	21-26 V
1.6 mm	260-310 A	22-27 V
1.6 mm	240-300 A	22-27 V
1.6 mm	280-320 A	24-28 V
1.6 mm	290-340 A	26-30 V
2.0 mm	280-400 A	26-31 V
2.4 mm	280-400 A	26-31 V
2.4 mm	280-360 A	26-30 V
2.4 mm	300-400 A	26-30 V

OK Autrod 4047

OK Autrod 4047 was originally developed as a brazing alloy to take advantage of its low melting point and narrow freezing range. In addition, it has higher silicon content than OK Autrod 4043, which provides an increased fluidity and reduced shrinkage. The alloy produces bright and almost smut free welds. Hot cracking is significantly reduced when using OK Autrod 4047 as a filler alloy. The alloy may be used in applications of sustained elevated temperatures. Non-Heat treatable.

Specifications	
Classifications	SFA/AWS A5.10 : ER4047 EN ISO 18273 : S Al 4047 (AlSi12)
Approvals	CWB : AWS A5.10

Approvals are based on factory location. Please contact ESAB for more information.

Alloy Type	AISI
Shielding Gas	I1, I3 (EN ISO 14175)

Typical Tensile Properties			
Condition	Yield Strength	Tensile Strength	Elongation
As Welded	55 MPa	124 MPa	12 %

Typical Wire Composition %					
Mn	Si	Al	Cu	Zn	Fe
0.01	11.5	Rem	0.01	0.01	0.18

Recommended Welding Parameters		
Wire Diameter	Current	Voltage
0.8 mm	60-170 A	13-24 V
0.8 mm	100-130 A	18-22 V
0.8 mm	125-150 A	20-24 V
0.9 mm	60-170 A	13-24 V
0.9 mm	85-120 A	20-23 V
0.9 mm	125-150 A	20-24 V
0.9 mm	170-190 A	21-26 V
1.0 mm	90-275 A	15-26 V
1.2 mm	140-260 A	20-29 V
1.2 mm	180-210 A	22-26 V
1.2 mm	170-240 A	24-28 V
1.2 mm	125-150 A	20-24 V
1.2 mm	140-300 A	20-29 V
1.6 mm	190-350 A	25-30 V
1.6 mm	190-260 A	21-26 V
1.6 mm	240-300 A	22-27 V
1.6 mm	260-310 A	22-27 V
1.6 mm	280-320 A	24-28 V
1.6 mm	290-340 A	26-30 V

OK Autrod 5087

Continuous solid wire suitable for welding of aluminium alloys with up to 5 % Mg and alloys where a higher tensile strength is required. The alloying element Zr gives improved properties against hot cracking during solidification.

Specifications	
Classifications	SFA/AWS A5.10 : ER5087 EN ISO 18273 : S Al 5087 (AlMg4,5MnZr)
Approvals	CE : EN 13479 DB : 61.039.07 UKCA : EN 13479 VdTÜV : 05816 VdTÜV : 05816

Approvals are based on factory location. Please contact ESAB for more information.

Alloy Type	AlMgMn
Shielding Gas	11, 12, 13 (EN ISO 14175)

Typical Tensile Properties			
Condition	Yield Strength	Tensile Strength	Elongation
As Welded	130 MPa	280 MPa	30 %

Typical Charpy V-Notch Properties		
Condition	Testing Temperature	Impact Value
As Welded	20 °C	35 J

Typical Wire Composition %									
Mn	Si	Cr	Al	Cu	Ti	Zn	Zr	Fe	Mg
0.8	0.04	0.08	Rem	0.01	0.08	0.01	0.11	0.12	4.7

Recommended Welding Parameters		
Wire Diameter	Current	Voltage
1.0 mm	90-275 A	15-26 V
1.2 mm	140-260 A	20-29 V
1.2 mm	140-300 A	20-29 V
1.6 mm	190-350 A	25-30 V

OK Autrod 5183

OK Autrod 5183 was developed to provide the highest strengths possible in the as welded condition of alloy AA 5083 and other similar high magnesium alloys. The more common 5356 grade will typically fail to meet the as-welded tensile requirements of AA 5083. The alloy is typically utilised in marine and structural applications where high strengths, high fracture toughness for impact resistance and exposure to corrosive elements are important. The alloy is not recommended for elevated temperature applications due to its susceptibility to stress corrosion cracking. The alloy is non-heat treatable.

Specifications	
Classifications	SFA/AWS A5.10 : ER5183 EN ISO 18273 : S Al 5183 (AlMg4,5Mn0,7(A))
Approvals	ABS : WC ABS : ER 5183 BV : WC CE : EN 13479 ClassNK : KAI5RCG(I) CWB : ER5183 DB : 61.039.03 DNV : 5183 LR : WC1/II-1 S RINA : WC (*) UKCA : EN 13479 VdTUV : 04666

Approvals are based on factory location. Please contact ESAB for more information.

Alloy Type	AlMgMn
Shielding Gas	I1, I3 (EN ISO 14175)

Typical Charpy V-Notch Properties		
Condition	Testing Temperature	Impact Value
As Welded	20 °C	90 J

Typical Wire Composition %									
Mn	Si	Cr	Al	Cu	Ti	Zn	Fe	Mg	
0.65	0.04	0.08	94.200	0.01	0.100	0.01	0.13	4.9	

Recommended Welding Parameters		
Wire Diameter	Current	Voltage
1.0 mm	90-275 A	15-26 V
1.2 mm	140-300 A	20-29 V
1.6 mm	190-350 A	25-30 V

OK Autrod 5356

OK Autrod 5356 is the most widely used welding alloy and can be classified as a general purpose type filler alloy. OK Autrod 5356 is typically chosen because of its relatively high shear strength. The 5XXX alloy base material, welded with OK Autrod 5356, with a weld pool chemistry greater than 3 % Mg and service temperatures in excess of 65 °C are susceptible to stress corrosion cracking. The alloy is non-heat treatable.

Specifications	
Classifications	SFA/AWS A5.10 : ER5356 EN ISO 18273 : S Al 5356 (AlMg5Cr(A))
Approvals	ABS : WB ABS : ER 5356 BV : WB CE : EN 13479 CWB : ER5356 DB : 61.039.01 DNV : 5356 LR : WB/I-1 S RINA : WB RINA : WC (*) UKCA : EN 13479 VdTUV : 04664

Approvals are based on factory location. Please contact ESAB for more information.

Alloy Type	AlMg 5
Shielding Gas	11, 13 (EN ISO 14175)

Typical Wire Composition %							
Mn	Si	Cr	Al	Cu	Zn	Fe	Mg
0.13	0.05	0.12	94.560	0.01	0.01	0.13	4.9

Recommended Welding Parameters		
Wire Diameter	Current	Voltage
0.8 mm	60-170 A	13-24 V
1.0 mm	90-275 A	15-26 V
1.2 mm	140-300 A	20-29 V
1.6 mm	190-350 A	25-30 V
2.4 mm	280-400 A	26-31 V

OK Autrod 5554

OK Autrod 5554 is a solid aluminium wire with a content of 2,7 % Mg. It's recommended for welding of AlMg alloys like 5454. Typical applications are chemical storage tanks, automotive components like wheels and frame sections. The weld metal is not sensitive to stress corrosion cracking at elevated temperatures.

Specifications

Classifications	SFA/AWS A5.10 : ER5554 EN ISO 18273 : S Al 5554 (AlMg2,7Mn)
Approvals	CE : EN 13479 CWB : A5.10/A5.10:2012 ER5554

Approvals are based on factory location. Please contact ESAB for more information.

Alloy Type	AlMg 2.7Mn
-------------------	------------

Typical Tensile Properties

Condition	Yield Strength	Tensile Strength	Elongation
As Welded	110 MPa	230 MPa	17 %

Typical Wire Composition %

Mn	Si	Cr	Al	Cu	Ti	Zn	Fe	Mg
0.7	0.1	0.1	96	0.01	0.15	0.01	0.1	2.7

Recommended Welding Parameters

Wire Diameter	Current	Voltage
1.2 mm	140-260 A	20-29 V
1.2 mm	125-150 A	20-24 V
1.2 mm	180-210 A	22-26 V
1.2 mm	170-240 A	24-28 V
1.2 mm	140-300 A	20-29 V
1.6 mm	190-350 A	25-30 V
1.6 mm	240-300 A	22-27 V
1.6 mm	190-260 A	21-26 V
1.6 mm	290-340 A	26-30 V
1.6 mm	260-310 A	22-27 V
1.6 mm	280-320 A	24-28 V

OK Autrod 5556

Continuous solid wire suitable for welding of aluminium alloys with up to approx. 5 % Mg that are not age-hardenable and alloys where a higher tensile strength is required. The corrosion resistance in marine atmosphere is high.

Specifications	
Classifications	SFA/AWS A5.10 : ER5556 EN ISO 18273 : S Al 5556A (AlMg5Mn1Ti)
Approvals	ABS : ER 5556 BV : WC ClassNK : KA15WCG (I) CWB : ER5556

Approvals are based on factory location. Please contact ESAB for more information.

Alloy Type	AlMgMn
Shielding Gas	I1, I2, I3 (EN ISO 14175)

Typical Tensile Properties			
Condition	Yield Strength	Tensile Strength	Elongation
As Welded	145 MPa	295 MPa	25 %

Typical Charpy V-Notch Properties		
Condition	Testing Temperature	Impact Value
As Welded	20 °C	24 J

Typical Wire Composition %									
Mn	Si	Cr	Al	Cu	Ti	Zn	Fe	Mg	
0.7	0.05	0.10	Rem	0.01	0.080	0.005	0.12	5.2	

Deposition Data				
Diameter	Current	Voltage	Wire Feed Speed	Deposition Rate
1.0 mm	90-180 A	22-26 V	7.0-14.0 m/min	0.9-1.8 kg/h

Recommended Welding Parameters		
Wire Diameter	Current	Voltage
1.2 mm	140-260 A	20-29 V
1.2 mm	125-150 A	20-24 V
1.2 mm	180-210 A	22-26 V
1.2 mm	170-240 A	24-28 V
1.2 mm	140-300 A	20-29 V
1.6 mm	190-350 A	25-30 V
1.6 mm	240-300 A	22-27 V
1.6 mm	190-260 A	21-26 V
1.6 mm	290-340 A	26-30 V
1.6 mm	260-310 A	22-27 V
1.6 mm	280-320 A	24-28 V
2.4 mm	280-400 A	26-31 V

OK Tigrod 1070

OK Tigrod 1070 is highly resistant to chemical attack and weathering. It is a relatively soft alloy that is very formable and is used extensively in thin gauge and foil products. It has good welding characteristics. A desirable characteristic of the alloy is the bright finishes obtained by anodising. Non-Heat treatable.

Specifications

Classifications	EN ISO 18273 : S Al 1070 (Al99,7)
------------------------	-----------------------------------

Alloy Type	Al
Shielding Gas	11, 13 (EN ISO 14175)

Typical Tensile Properties

Condition	Yield Strength	Tensile Strength	Elongation
As Welded	35 MPa	75 MPa	33 %

Typical Wire Composition %

Mn	Si	V	Al	Cu	Fe
0.01	0.02	0.01	99.80	0.01	0.13

OK Tigrod 1100

OK Tigrod 1100 is highly resistant to chemical attack and weathering. It is a relatively soft alloy that is very formable and is used extensively in thin gauge and foil products. It has good welding characteristics. A desirable characteristic of the alloy is the bright finishes obtained by anodising. Non-Heat treatable.

Specifications

Classifications	SFA/AWS A5.10 : R1100 EN ISO 18273 : S Al 1100 (Al99,0Cu)
Approvals	CWB : AWS A5.10/A5.10M:2012 (ER1100)

Approvals are based on factory location. Please contact ESAB for more information.

Alloy Type	Al
Shielding Gas	I1, I3 (EN 439)

Typical Tensile Properties

Condition	Yield Strength	Tensile Strength	Elongation
As Welded	30 MPa	75 MPa	35 %

Typical Wire Composition %

Cu	Si+Fe	Zn	Be
0.07	0.55	0.01	0.0001

Tigrod 1450

Tigrod 1450 is highly resistant to chemical attack and weathering. The alloy has a small addition of titanium, which has a grainrefining effect, which reduces the cracking susceptibility. It has good welding characteristics. A desirable characteristic of the alloy is the bright finishes obtained by anodising. Non Heat treatable.

Specifications

Classifications	EN ISO 18273 : S Al 1450 (Al99,5Ti)
------------------------	-------------------------------------

Alloy Type	Al
Shielding Gas	I1, I3 (EN ISO 14175)

Typical Tensile Properties

Condition	Yield Strength	Tensile Strength	Elongation
As Welded	40 MPa	90 MPa	35 %

Typical Wire Composition %

Mn	Si	Al	Cu	Ti	Zn	Fe
0.02	0.02	99.8	0.01	0.12	0.01	0.16

OK Tigrod 4043

OK Tigrod 4043 is one of the most widely used welding alloys. The alloy is used for welding AlMgSi - types and AlSi - alloys with up to 7 % Silicon. Not recommended for anodizing. Non-Heat treatable.

Specifications	
Classifications	SFA/AWS A5.10 : R4043 EN ISO 18273 : S Al 4043 (AISI5)
Approvals	CE : EN 13479 DB : 61.039.06 UKCA : EN 13479 CWB : R4043

Approvals are based on factory location. Please contact ESAB for more information.

Alloy Type	AISI
Shielding Gas	I1, I3 (EN ISO 14175)

Typical Tensile Properties		
Condition	Yield Strength	Tensile Strength
As Welded	85 MPa	185 MPa

Typical Wire Composition %						
Mn	Si	Al	Cu	Ti	Zn	Fe
0.01	5.00	Rem	0.02	0.01	0.01	0.14

OK Tigrod 4047

OK Tigrod 4047 was originally developed as a brazing alloy to take advantage of its low melting point and narrow freezing range. In addition, it has higher silicon content than OK Tigrod 4043, which provides an increased fluidity and reduced shrinkage. Hot cracking is significantly reduced when using OK Autrod 4047 as a filler alloy. The alloy may be used in applications of sustained elevated temperatures. Non-Heat treatable.

Specifications

Classifications	SFA/AWS A5.10 : R4047 EN ISO 18273 : S Al 4047 (AlSi12)
Approvals	CE : EN 13479 CWB : R4047 UKCA : EN 13479

Approvals are based on factory location. Please contact ESAB for more information.

Alloy Type	Alloyed aluminium (Al + 12 % Si)
Shielding Gas	I1, I3 (EN ISO 14175)

Typical Tensile Properties

Condition	Yield Strength	Tensile Strength
As Welded	125 MPa	230 MPa

Typical Wire Composition %

Mn	Si	Al	Cu	Zn	Fe
0.01	11.5	Rem	0.01	0.01	0.18

OK Tigrod 5087

Bare welding rod suitable for welding of aluminium alloys with up to 5 % Mg and alloys where a higher tensile strength is required. The alloying element Zr gives improved properties against hot cracking during solidification.

Specifications	
Classifications	SFA/AWS A5.10 : R5087 EN ISO 18273 : S Al 5087 (AlMg4,5MnZr)
Approvals	CE : EN 13479 DB : 61.039.08 VdTÜV : 05796

Approvals are based on factory location. Please contact ESAB for more information.

Alloy Type	AlMgMn
Shielding Gas	11, 12, 13 (EN ISO 14175)

Typical Tensile Properties			
Condition	Yield Strength	Tensile Strength	Elongation
As Welded	130 MPa	280 MPa	30 %

Typical Charpy V-Notch Properties		
Condition	Testing Temperature	Impact Value
As Welded	20 °C	35 J

Typical Wire Composition %									
Mn	Si	Cr	Al	Cu	Ti	Zn	Zr	Fe	Mg
0.8	0.04	0.08	Rem	0.01	0.08	0.01	0.11	0.12	4.7

OK Tigrod 5183

OK Tigrod 5183 was developed to provide the highest strengths possible in the as welded condition of alloy AA 5083 and other similar high magnesium alloys. The more common OK Tigrod 5356 will typically fail to meet the as-welded tensile requirements of AA 5083. The alloy is typically utilised in marine and structural applications where high strengths, high fracture toughness for impact resistance and exposure to corrosive elements are important. The alloy is not recommended for elevated temperature applications due to its susceptibility to stress corrosion cracking. The alloy is non-heat treatable.

Specifications

Classifications	SFA/AWS A5.10 : R5183 EN ISO 18273 : S Al 5183 (AlMg4,5Mn0,7(A))
Approvals	ABS : R 5183 CE : EN 13479 CWB : R5183 DB : 61.039.04 NAKS/HAKC : 3.2 - 4.0 MM VdTUV : 04667

Approvals are based on factory location. Please contact ESAB for more information.

Alloy Type	AlMgMn
Shielding Gas	I1, I3 (EN ISO 14175)

Typical Tensile Properties

Condition	Yield Strength	Tensile Strength	Elongation
As Welded	140 MPa	290 MPa	25 %

Typical Charpy V-Notch Properties

Condition	Testing Temperature	Impact Value
As Welded	20 °C	90 J

Typical Wire Composition %

Mn	Si	Cr	Al	Cu	Ti	Zn	Fe	Mg
0.65	0.04	0.08	94.200	0.01	0.100	0.01	0.13	4.9

OK Tigrod 5356

OK Tigrod 5356 is the most widely used welding alloy and can be classified as a general purpose type filler alloy. OK Tigrod 5356 is typically chosen because of its relatively high shear strength. The 5XXX alloy base material, welded with OK Tigrod 5356, with a weld pool chemistry greater than 3 % Mg and service temperatures in excess of 65 °C are susceptible to stress corrosion cracking. The alloy is non-heat treatable.

Specifications	
Classifications	SFA/AWS A5.10 : R5356 EN ISO 18273 : S Al 5356 (AlMg5Cr(A))
Approvals	ABS : R 5356 CE : EN 13479 CWB : R5356 DB : 61.039.02 VdTÜV : 04665

Approvals are based on factory location. Please contact ESAB for more information.

Alloy Type	AlMg 5
Shielding Gas	11, 13 (EN ISO 14175)

Typical Wire Composition %							
Mn	Si	Cr	Al	Cu	Zn	Fe	Mg
0.13	0.05	0.12	94.560	0.01	0.01	0.13	4.9

OK Tigrod 5554

OK Tigrod 5554 is a solid aluminium rod with a content of 2,7% Mg. It's recommended for welding of AlMg alloys like 5454. Typical applications are chemical storage tanks, automotive components like wheels and frame sections. The weld metal is not sensitive to stress corrosion cracking at elevated temperatures.

Specifications

Classifications	SFA/AWS A5.10 : R5554 EN ISO 18273 : S Al 5554 (AlMg2,7Mn)
Approvals	CWB : R5554

Approvals are based on factory location. Please contact ESAB for more information.

Alloy Type	AlMg 5
-------------------	--------

Typical Tensile Properties

Condition	Yield Strength	Tensile Strength	Elongation
As Welded	110 MPa	230 MPa	17 %

Typical Wire Composition %

Mn	Si	Cr	Al	Cu	Ti	Zn	Fe	Mg
0.7	0.1	0.1	96	0.01	0.15	0.01	0.1	2.7

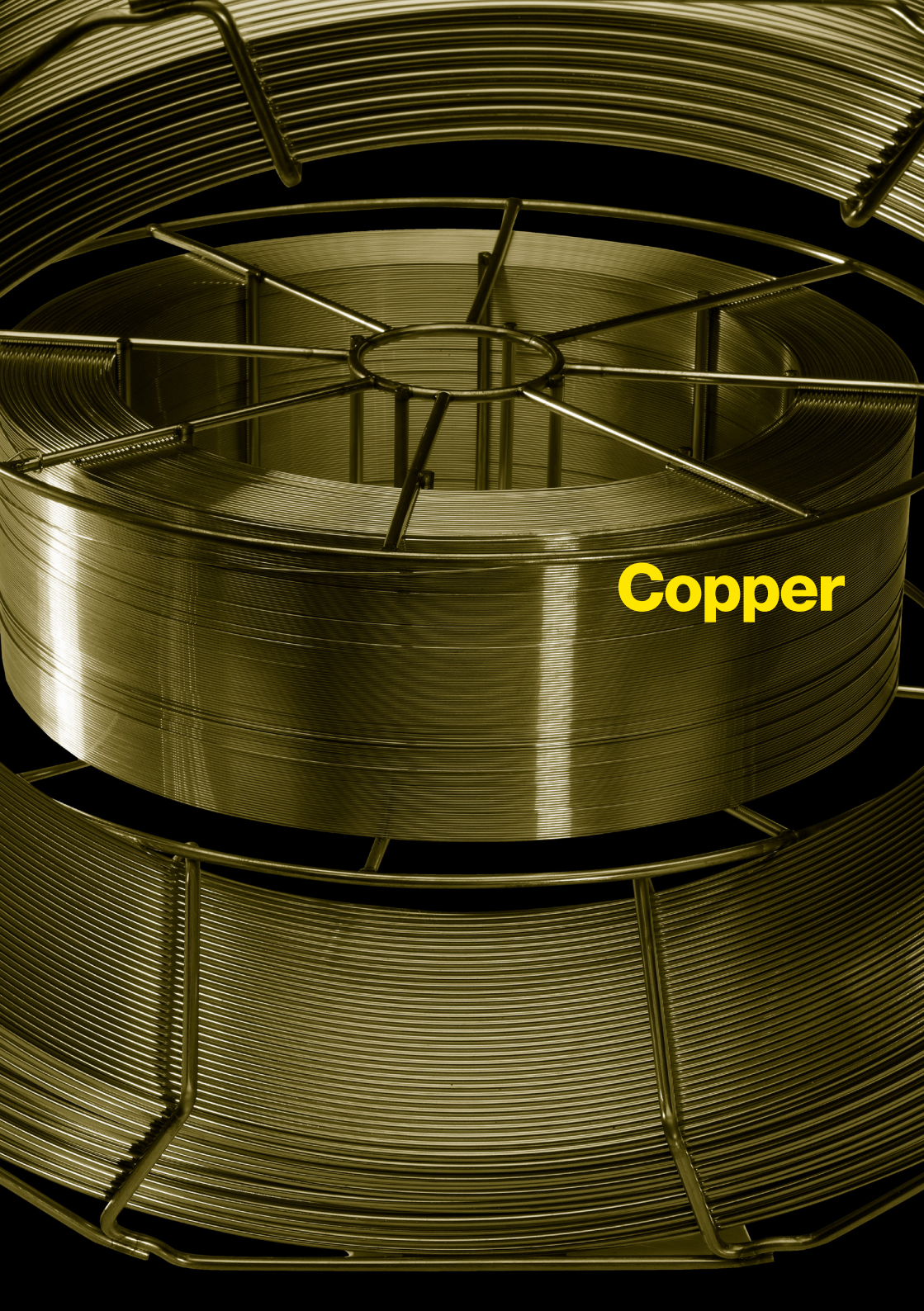

Copper



Welding Copper and Copper Alloys	7-3
STICK ELECTRODES (SMAW).....	7-5
OK 94.25.....	7-5
OK 94.35.....	7-6
MIG WIRES/TIG RODS (GMAW/GTAW).....	7-7
OK Autrod 19.12	7-7
OK Autrod 19.30	7-8
OK Autrod 19.40	7-9
OK Autrod 19.41	7-10
OK Autrod 19.46	7-11
OK Autrod 19.49	7-12
OK Autrod CuSi Laser	7-13
OK Tigrod 19.12.....	7-14
OK Tigrod 19.30.....	7-15
OK Tigrod 19.40.....	7-16
OK Tigrod 19.41.....	7-17
OK Tigrod 19.49.....	7-18

1. Pure copper

Pure copper that is to be welded must be completely free of oxygen. These copper grades are usually deoxidised with phosphorus, but the low phosphorus content impairs electrical conductivity. SE-Cu that has been deoxidised with other elements such as lithium or boron should therefore be used for electrical parts intended for welding. The excellent thermal conductivity of copper requires high preheating temperatures and a strong, concentrated heat input.

2. Copper alloys

Alloying elements give different types of bronze greater strength and higher resistance to wear and corrosion. In contrast, electrical and thermal conductivity are lower, which improves weldability.

2.1. Brass

Brass types contain zinc as the main alloying element, with a minimum of 50% copper forming the base. They may also contain other alloying elements. The zinc they contain also evaporates, leading to the formation of pores by zinc oxide. Welding consumables containing Al or Si have proven to be advantageous; gas welding should be carried out with an excess of oxygen.

2.2. Aluminium Bronzes

Aluminium bronzes with increased aluminium content form a passive Al_2O_3 film, as is known from aluminium alloys. This oxide film must be broken up prior to welding, which is why a flux containing fluorides is used for gas or TIG welding is performed using an alternating current. Aluminium composite bronzes also contain Ni, Mn and Fe to improve strength and wear resistance.

2.3. Copper-Nickel Alloys

Copper-nickel alloys are easy to weld and their

low thermal conductivity means that no preheating is necessary. If oxide layers form during welding, a flux is recommended.

2.4. Joining Copper Alloys With Steel

2.4.1. Secondary Joints

All copper-based welding consumables suitable for surfacing on steel are suitable for joining copper alloys with steel. It should be noted that joints of this type may only be exposed to relatively low, non-variable loads. The reason for this is “solder cracking”, i.e. copper can penetrate into the grain boundaries at the melting line on the steel side and form low-melting and low-strength “solders” with the elements present there.

The following materials are suitable for secondary joints:

Pure copper, brass, silicon bronzes with mild and low-alloy steel:

Alloy type CuSi3Mn1:	OK Autrod 19.30 OK Tigrod 19.30
----------------------	------------------------------------

Aluminium bronzes with mild and low-alloy steel:

Alloy type CuAl7:	OK Autrod 19.40
-------------------	-----------------

Aluminium composite bronzes with mild and low-alloy steel:

Alloy type CuAl8Ni2Fe2Mn2:	OK Autrod 19.41
-------------------------------	-----------------

Nickel bronzes with mild and low-alloy steel:

Alloy type CuNi30Mn1FeTi:	OK Autrod 19.49 OK Tigrod 19.49
------------------------------	------------------------------------

Procedure:

It is common practice to ‘butter’ steel surfaces of the joint preparation with bronze filler metal prior to welding. This then creates a bronze/bronze connection.

2.4.2. High-quality joints

To avoid solder cracking in joints with more demanding requirements and when welding copper to steel, an alloy barrier must be created to prevent contact between liquid copper and the steel side.

Nickel-based welding consumables are used here because they are suitable for welding steels and are fully miscible with copper:

Alloy type Ni:	OK Autrod Ni-1 OK Tigrod Ni-1
Alloy type NiCu:	OK NiCu-7 OK Autrod NiCu-7 OK Tigrod NiCu-7

For smaller metal thicknesses, welding is carried out directly using nickel-based welding consumables.

For larger thicknesses:

- Buttering the steel side (or copper side) with nickel-based filler material.
- Completing the weld with nickel-based filler material.

3. Welding Processes

3.1. Gas Welding

A flux is usually used for gas welding.

For metal thicknesses $s > 6$ mm, welding is performed simultaneously on both sides in a vertical position.

For pure copper, preheat well and peen the joint to increase strength.

3.2. TIG Welding

Fluxes are also occasionally used for TIG welding of pure copper and brass. For thin metal sheets, welding is performed on one side, and for sheets thicker than 3.5 mm, it is performed simultaneously on both sides in a vertical position.

Fillet welds should only be welded up to a maximum wall thickness of 5 mm; for larger

wall thicknesses, MIG welding should be used. Shielding gases: Ar, He and their mixtures.

3.3. MIG Welding

The MIG process is usually employed for larger metal thicknesses, e.g. for fillet welds.

Careful attention must be paid to extraction because copper dust is created during welding.

Ar, He and their mixtures are used as shielding gases. Advantageous: pulsed arc welding.

3.4. MMA Welding

For MMA welding with coated stick electrodes, included angles of 90° are used for butt welds.

Strive for a high heat input, select the largest possible electrode diameter, weave slightly, and maintain a short arc.

Tin bronzes and pure copper with wall thicknesses above 5 mm must be preheated to approx. 500°C, and for aluminium bronzes with greater wall thicknesses, to approx. 250°C.

OK 94.25



Electrode for welding copper and bronzes, especially tin-bronzes. It is also suitable for cladding steels and for smaller repair work of weldable cast irons.

Specifications	
Classifications	EN ISO 17777 : E Cu Z (CuSn7)

Welding Current	DC+
Alloy Type	Copper alloy
Coating Type	Basic

Typical Tensile Properties			
Condition	Yield Strength	Tensile Strength	Elongation
ISO			
As Welded	235 MPa	360 MPa	25 %

Typical Charpy V-Notch Properties		
Condition	Testing Temperature	Impact Value
ISO		
As Welded	20 °C	25 J
As Welded	0 °C	20 J

Typical Weld Metal Analysis %		
Mn	Cu	Sn
0.4	93	6.5

Deposition Data					
Diameter	Current	Voltage	Efficiency (%)	Fusion time per electrode at 90° I max	Deposition Rate
2.5 x 350 mm	60-90 A	22 V	71 %	39 sec	1.2 kg/h
3.2 x 350 mm	90-125 A	24 V	72 %	40 sec	1.9 kg/h
4.0 x 350 mm	125-170 A	25 V	74 %	41 sec	2.9 kg/h

OK 94.35



OK 94.35 is a copper-nickel type welding electrode used for chemical process equipment, desalination plants and offshore application. It is suitable for joining and cladding of matching as well as dissimilar alloys.

Specifications

Classifications	SFA/AWS A5.6 : ECuNi EN ISO 17777 : E Cu 7158 (CuNi30Mn2FeTi)
Welding Current	DC+
Alloy Type	Copper Nickel
Coating Type	Basic

Typical Weld Metal Analysis %

Mn	Ni	Cu	Fe
1.6	30	67	0.6

Deposition Data

Diameter	Current	Voltage	Efficiency (%)	Fusion time per electrode at 90% I max	Deposition Rate
2.5 x 300 mm	55-70 A	22 V	64 %	49 sec	3.9 kg/h
3.2 x 350 mm	70-120 A	23 V	66 %	50 sec	4.4 kg/h

OK Autrod 19.12

A continuous solid copper wire for welding of oxygen free, pure copper and low alloyed copper. OK Autrod 19.12 is alloyed with tin, and has good flow properties. The weld is easily workable. For welding of large work pieces and heavy thickness preheating is recommended.

Specifications

Classifications	SFA/AWS A5.7 : ERCu EN ISO 24373 : CuSn1
------------------------	---

Alloy Type	Copper (Cu + 0.7 % Sn)
-------------------	------------------------

Typical Tensile Properties

Condition	Yield Strength	Tensile Strength	Elongation
As Welded	75 MPa	220 MPa	30 %

Typical Wire Composition %

Mn	Si	Cu	Fe
0.2	0.2	Bal	0.05

Recommended Welding Parameters

Wire Diameter	Current	Voltage	Wire Feed Speed
0.8 mm	60-165 A	13-17.5 V	4.0-13.0 mm/min
1.0 mm	80-210 A	12.5-18 V	4.0-12.0 mm/min
1.2 mm	150-320 A	16-29 V	5.0-11.5 mm/min

OK Autrod 19.30

A continuous, solid copper wire, for welding of copper-zinc alloys, low-alloyed copper and for Mig brazing of zinc coated steel sheets. OK Autrod 19.30 is alloyed with silicon and manganese. The alloy is widely used in the automotive industry for Mig brazing of galvanised steel in car body production. The wire is also suitable for overlay welding of un- and low alloyed steels. Pulsed GMAW is recommended.

Specifications

Classifications	SFA/AWS A5.7 : ERCuSi-A EN ISO 24373 : CuSi3Mn1
Approvals	VdTÜV : 09147

Approvals are based on factory location. Please contact ESAB for more information.

Alloy Type	Alloyed copper (Cu + 3 % Si)
Shielding Gas	I1, I2, I3, M13 (EN439)

Typical Tensile Properties

Condition	Yield Strength	Tensile Strength	Elongation
As Welded	130 MPa	350 MPa	40 %

Typical Weld Metal Analysis %

Mn	Si	P	Ni	Al	Sn	Pb	Fe
0.8	3	0.005	0.005	0.004	0	0.003	0.05

Typical Wire Composition %

Mn	Si	Cu	Sn	Zn	Fe
0.9	3	96	0.01	0.05	0.05

Recommended Welding Parameters

Wire Diameter	Current	Voltage	Wire Feed Speed
0.8 mm	60-165 A	13-17.5 V	4.0-13.0 mm/min
1.0 mm	80-210 A	12.5-18 V	4.0-12.0 mm/min
1.2 mm	150-320 A	16-29 V	5.0-11.5 mm/min
1.6 mm	-	-	-

OK Autrod 19.40

A continuous solid copper wire for welding of aluminium bronzes of the same type and over lay welding of un- and low alloyed steels. OK Autrod 19.40 is alloyed with aluminium and is recognised for high strength, good wear resistance and very good corrosion resistance against sea water. The alloy is also commonly used in the automotive industry for Mig brazing of galvanised steel in car body production.

Specifications	
Classifications	SFA/AWS A5.7 : ERCuAl-A1 EN ISO 24373 : S Cu 6100 (CuAl7)

Alloy Type	Alloyed copper (Cu + 8 % Al)
Shielding Gas	I1, I2, I3, M13 (EN439)

Typical Tensile Properties			
Condition	Yield Strength	Tensile Strength	Elongation
As Welded	175 MPa	420 MPa	40 %

Typical Weld Metal Analysis %					
Mn	Si	Al	Pb	Zn	Fe
0.2	0.05	8	0.003	0.05	0.1

Typical Wire Composition %					
Mn	Si	Al	Pb	Zn	Fe
0.3	0.1	7	0.01	0.1	0.4

Recommended Welding Parameters			
Wire Diameter	Current	Voltage	Wire Feed Speed
0.8 mm	60-165 A	13-17.5 V	4.0-13.0 mm/min
1.0 mm	80-210 A	12.5-18 V	4.0-12.0 mm/min
1.2 mm	150-320 A	16-29 V	5.0-11.5 mm/min
1.6 mm	-	-	-

OK Autrod 19.41

A continuous solid aluminium bronze electrode alloyed with Ni. OK Autrod 19.41 is used for overlay welding of steel and for welding of cast or wrought nickel-aluminium bronze materials. The alloy has very good resistance to seawater

Specifications

Classifications	EN ISO 24373 : CuAl8Ni2Fe2Mn2
------------------------	-------------------------------

Alloy Type	Alloyed copper (Cu + 8 % Al + 2 % Ni)
-------------------	---------------------------------------

Typical Weld Metal Analysis %

Mn	Si	Ni	Al	Cu	Zn	Fe
2	0.05	2	8.0	85.00	0.04	2.5

Typical Wire Composition %

Mn	Si	Ni	Al	Cu	Zn	Fe
2	0.05	2	8.0	85.00	0.04	2.5

Recommended Welding Parameters

Wire Diameter	Current	Voltage	Wire Feed Speed
1.2 mm	150-320 A	16-29 V	5.0-11.5 mm/min

OK Autrod 19.46

A continuous solid Cu-Mn-Al-electrode for weld cladding and joining of Cu-Al-alloys alloyed with Ni and Mn. Produces a wear-, corrosion- and sea water resistant layer on steel and cast iron. The alloy has a rather high resistance against erosion and cavitation.

Specifications

Classifications	SFA/AWS A5.7 : ERCuMnNiAl EN ISO 24373 : CuMn13Al8Fe3Ni2
------------------------	---

Alloy Type	Alloyed copper (Cu +13 % Mn + 7 % Al + 2 % Ni)
Shielding Gas	Inert gas (Ar, Ar/He-mixtures, He)

Typical Weld Metal Analysis %

Mn	Ni	Al	Fe
13	2	8	2.5

Typical Wire Composition %

Mn	Ni	Al	Fe
13	2	8	2.5

Recommended Welding Parameters

Wire Diameter	Current	Voltage	Wire Feed Speed
1.2 mm	150-320 A	16-29 V	5.0-11.5 mm/min

OK Autrod 19.49

A continuous solid Cu-Ni wire for welding of similar alloys like 90Cu10Ni-, 80Cu20Ni- and 70Cu30Ni-alloys. The nickel addition strengthens the weld metal and improves the corrosion resistance, particularly against salt water. The alloy is used for overlay welding of steels and widely used for welding of Cu-Ni components to desalination plants.

Specifications	
Classifications	EN ISO 24373 SFA/AWS A5.7 : ERCuNi EN 14640 : S Cu 7158 (CuNi30)

Alloy Type	Alloyed copper (Cu + 30 % Ni)
Shielding Gas	I1, I2, I3 (EN 439)

Typical Tensile Properties			
Condition	Yield Strength	Tensile Strength	Elongation
As Welded	180 MPa	350 MPa	40 %

Typical Weld Metal Analysis %						
Mn	Si	P	Ni	Al	Pb	Fe
0.8	0.05	0.04	31	0.001	0.005	0.6

Typical Wire Composition %					
C	Mn	Si	Ni	Cu	Fe
0.02	0.7	0.05	31	Bal	0.5

Recommended Welding Parameters			
Wire Diameter	Current	Voltage	Wire Feed Speed
0.8 mm	60-165 A	13-17.5 V	4.0-13.0 mm/min
1.0 mm	80-210 A	12.5-18 V	4.0-12.0 mm/min
1.2 mm	150-320 A	16-29 V	5.0-11.5 mm/min

OK Autrod CuSi Laser

A solid copper wire intended for laser brazing of zinc coated steel sheets. OK Autrod CuSi Laser is especially developed for laser brazing of body-in-white applications within the automotive industry. Compared to a standard CuSi3Mn1 copper wire OK Autrod CuSi Laser provides a more stable brazing process as well as a superior surface finish.

Specifications

Classifications	SFA/AWS A5.7 : ERCuSi-A EN ISO 24373 : Cu 6560 (CuSi3Mn1)
Alloy Type	S Cu 6560 (CuSi3Mn1)
Shielding Gas	C1 (EN ISO 14175)

Typical Tensile Properties

Condition	Yield Strength	Tensile Strength	Elongation
As Welded	130 MPa	350 MPa	40 %

Typical Wire Composition %

Mn	Si	Cu	Sn	Zn	Fe
0.9	2.85	96	0	0.05	0.05

Recommended Welding Parameters

Wire Diameter	Current	Voltage	Wire Feed Speed
0.8 mm	130-150 A	20-24 V	11.7-12.7 mm/min
0.9 mm	145-185 A	22-26 V	10.2-11.2 mm/min
1.0 mm	155-210 A	24-28 V	9.1-10.1 mm/min
1.2 mm	195-215 A	25-29 V	7.1-7.9 mm/min
1.6 mm	260-280 A	26-30 V	3.8-5.3 mm/min

OK Tigrod 19.12

Bare copper welding rod alloyed with small amounts of tin for welding of oxygen free, pure copper and low alloyed copper. The weld is easily workable. For welding of large work pieces and heavy thickness preheating is recommended..

Specifications

Classifications	SFA/AWS A5.7 : ERCu EN ISO 24373 : CuSn1
------------------------	---

Alloy Type	Copper (Cu + 0.7 % Sn)
-------------------	------------------------

Typical Tensile Properties

Condition	Yield Strength	Tensile Strength	Elongation
As Welded	75 MPa	220 MPa	30 %

Typical Wire Composition %

Mn	Si	Cu	Fe
0.2	0.2	Bal	0.05

OK Tigrod 19.30

Bare copper welding rods containing approx. 3 % Si used for joining of copper-silicon and copper-zinc base metals and similar. Can also be used for overlay welding of un- and low alloyed steels.

Specifications

Classifications	SFA/AWS A5.7 : ERCuSi-A EN ISO 24373 : CuSi3Mn1
------------------------	--

Alloy Type	Alloyed copper (Cu + 3 % Si)
Shielding Gas	I1, I2, I3 (EN 439)

Typical Tensile Properties

Condition	Yield Strength	Tensile Strength	Elongation
As Welded	150 MPa	350 MPa	40 %

Typical Wire Composition %

Mn	Si	Cu	Sn	Zn	Fe
0.9	3	96	0.01	0.05	0.05

OK Tigrod 19.40

Bare aluminium bronze welding rods for welding of aluminium bronzes of the same type and over lay welding of un- and low alloyed steels. The alloy has a good corrosion resistance against sea water.

Specifications

Classifications	SFA/AWS A5.7 : ERCuAl-A1 EN ISO 24373 : CuAl7
------------------------	--

Alloy Type	Alloyed copper (Cu + 8 % Al)
Shielding Gas	I1, I2, I3 (EN 439)

Typical Tensile Properties

Condition	Yield Strength	Tensile Strength	Elongation
As Welded	175 MPa	420 MPa	40 %

Typical Wire Composition %

Mn	Si	Al	Pb	Zn	Fe
0.3	0.1	7	0.01	0.1	0.4

OK Tigrod 19.41

A solid aluminium bronze rod alloyed with Ni. OK Tigrod 19.41 is used for overlay welding of steel and for welding of cast or wrought nickel-aluminium bronze materials. The alloy has very good resistance to seawater

Specifications	
Classifications	BS 2901 part 3 : C29 DIN 1733 : Schweisstab SG-CuAl8Ni2, W.nr 2.0922
Alloy Type	Alloyed copper (Cu + 8 % Al + 2 % Ni)
Shielding Gas	I1, I2, I3 (EN 439)

OK Tigrod 19.49

Bare Cu-Ni rods for welding of similar alloys like 90Cu10Ni-, 80Cu20Ni- and 70Cu30Ni-alloys. The nickel addition strengthens the weld metal and improves the corrosion resistance, particularly against salt water. The alloy is used for overlay welding of steels and widely used for welding of Cu-Ni components to desalination plants.

Specifications

Classifications	SFA/AWS A5.7 : ERCuNi EN ISO 24373 : S Cu 7158 (CuNi30Mn1FeTi)
Approvals	ABS : ERCuNi VdTÜV : 11600

Approvals are based on factory location. Please contact ESAB for more information.

Alloy Type	Alloyed copper (Cu + 30 % Ni)
Shielding Gas	11, 12, 13 (EN ISO 14175)

Typical Tensile Properties

Condition	Yield Strength	Tensile Strength	Elongation
As Welded	180 MPa	350 MPa	40 %

Typical Wire Composition %

C	Mn	Si	Ni	Fe
0.02	0.7	0.05	31	0.5



Hardfacing



Welding Consumables for Repair Welding and Surfacing	8-3
STICK ELECTRODES (SMAW)	8-9
OK 13Mn	8-9
OK 14MnNi	8-10
OK Tooltrode 50	8-11
OK Tooltrode 60	8-12
OK Weartrode 30	8-13
OK Weartrode 30 HD	8-14
OK Weartrode 35	8-15
OK Weartrode 40	8-16
OK Weartrode 45	8-17
OK Weartrode 50	8-18
OK Weartrode 50 T	8-19
OK Weartrode 55	8-20
OK Weartrode 55 HD	8-21
OK Weartrode 60	8-22
OK Weartrode 60 T	8-23
OK Weartrode 62	8-24
OK Weartrode 65 T	8-25
MIG WIRES/TIG RODS (GMAW/GTAW)	8-26
OK Autrodur 38 G M	8-26
OK Autrodur 56 G M	8-27
OK Autrodur 58 G M	8-28
GAS-SHIELDED FLUX-CORED WIRES (FCAW/MCAW)	8-29
OK Tubrodur 13Cr G	8-29
OK Tubrodur 35 G M	8-30
OK Tubrodur 53 G M	8-31
OK Tubrodur 60 G M	8-32
SELF-SHIELDED FLUX-CORED WIRES (FCAW)	8-33
OK Tubrodur 13Mn O/G	8-33
OK Tubrodur 15CrMn O/G	8-34
OK Tubrodur 30 O M	8-35
OK Tubrodur 35 O M	8-36
OK Tubrodur 40 O M	8-37
OK Tubrodur 55 O A	8-38
OK Tubrodur 58 O/G M	8-39
OK Tubrodur 200 O D	8-40
SUBARC (SAW)	8-41
OK Tubrodur 12Cr S	8-41
OK Tubrodur 13Cr S	8-42
OK Tubrodur 23 Cr S	8-43
OK Tubrodur 35 S M	8-44
OK Tubrodur 40 S M	8-45
OK Tubrodur 58 S M	8-46
OK Flux 10.33	8-47
OK Flux 10.96	8-48
OK Flux 10.97	8-49
STRIP CLADDING (SAW/ESW)	8-50
OK Band 11.84	8-50
OK Band 430	8-51
OK Flux 10.07	8-52
OK Flux 10.10	8-53

1. Classification of Welding Consumables

The welding consumables for repair and surfacing welding are classified according to EN 14700 into alloy groups or alloy abbreviations (e.g. Fe1, Ni2, Cu1, etc.), the properties and areas of application of which are briefly explained below. (Literature: EN 14700: Welding consumables – Welding consumables for hard facing.)

Fe1

Welding consumables of this type are used for surfacing mild or low-alloy steels where there are no special requirements regarding the hardness of the weld metal. The weld metal has no particular resistance to wear and can be machined in the welded or tempered state. The alloys with $C \leq 0.4\%$ and usually up to 5 % alloying elements are less suitable for abrasive wear, but are advantageous for fatigue or adhesive wear, especially when machining is required. Suitable for soft and impact-resistant build-up welds, buffer layers before harder build-ups and filler welds to restore the original volume. The alloys mentioned include the heat-resistant, heat-treatable, nitritable and case-hardenable welding consumables, but also all unalloyed and low-alloy MMA electrodes, gas welding rods and welding consumables for gas-shielded arc welding.

According to EN 14700, the hardness values of the ferritic-martensitic weld metal are approx. 150 – 450 HB.

Special features:	impact-resistant ("p"), crack-resistant and easy to machine
Wear types:	friction wear, impact wear, rolling wear

Fe2

The higher carbon content $C = 0.4 - 1.5\%$ produces a more wear-resistant weld metal than in alloy group Fe1 due to higher martensite and carbide content. Some of the weld deposits are hardenable and temperable. Annealing processes can be used to improve the properties. The weld metal can often only be removed by grinding. The unalloyed and low-alloy tool and tempering steels that belong in this category are particularly suitable for fatigue loading and adhesion with metal friction.

According to EN 14700, the hardness values of the martensitic weld metal are approx. 30 – 58 HRC.

Special features:	impact-resistant ("p") and crack-resistant
Wear types:	friction wear, impact wear, rolling wear, groove wear

Fe3

The main applications include areas where a greater weld metal hardness is required at elevated temperatures. The welding consumables produce a weld metal with the characteristics of hot-work steels. They are usually alloyed with W, Cr and sometimes with Mo, Ni, V, less often with Co. The weld metal consists of martensite, residual austenite and carbides. For machining, it can be annealed and then hardened again. An optimal microstructure is achieved by tempering. Sufficient hot hardness can be achieved up to 550°C. When welding, it is recommended to preheat and cool down slowly to avoid cracking.

According to EN 14700, the hardness values of the martensitic-carbide weld metal are approx. 40 – 55 HRC.

Special features:	edge-holding ("s"), heat-resistant ("t") and crack-resistant, resistant to impact and thermal shock, as well as easy machinability (after annealing)
Wear types:	friction wear, impact wear, rolling wear, rolling-shock wear, thermal shock, impact-sliding wear and grain sliding wear at high temperatures.

Fe4

The additives produce a weld metal whose analysis corresponds to that of high speed steels, i.e. it is alloyed with C, Mo, Cr, W and V, in some cases with Co. Machining is only possible after annealing; in most cases the weld metal can only be machined by grinding. Hardening is not necessary, but is possible after prior solution annealing. Usually the material is annealed several times after welding in order to increase the hardness and improve the load-bearing characteristics. Main applications are found in tools, e.g. the production of cutting edges of cold and hot working tools. Preheating is usually essential for welding tool steels, while heat management must be adapted to the tool size and tool geometry (voltage sensitivity), the parent material and the welding material.

According to EN 14700, the hardness values of the martensitic-carbide weld metal are approx. 55 – 65 HRC.

Special features:	edge-holding ("s"), heat-resistant ("t"), moderately shock-resistant ("p"), but high temperature and thermal shock resistance
Wear types:	Rolling impact wear, thermal shock and impact-sliding wear at both high and low temperatures

Fe6

These alloys have carbon contents of up to $C \leq 2.5\%$. The weld metal is martensitic and mostly contains carbides. The weld metal is air-hardening and, untreated, can only be machined by grinding. Preheating is usually performed prior to welding to improve crack resistance. It is suitable for applications with abrasive stress, also in combination with pressure and light to medium impact loads. Typical applications include crusher rollers, mixer parts, earthmoving machinery and agricultural and forestry equipment. Another area of application is the welding of covering layers at joint seams on wear plates in order to prevent the weld seams from "washing out".

According to EN 14700, the hardness values of the martensitic-carbide weld metal are approx. 48 – 55 HRC

Special features:	abrasion-resistant ("g"), impact-resistant ("p"), edge-holding ("s"), but moderate high temperature and thermal shock resistance
Wear types:	Rolling impact wear, impact sliding wear, groove wear, grain sliding wear $\geq 500^\circ\text{C}$, flushing wear and fluid erosion

Fe7

The additions with $C \leq 0.2\%$ and 11 - 30 % Cr usually produce a weld metal of ferritic chromium steel. The formation of martensite components can be achieved by maintaining the upper C content of 0.2% or by adding other alloying elements such as nickel. A wide range of applications is covered by the 13% and 17% chromium steels. Rust and scale-resistant welding consumables can be applied to similar or unalloyed and low-alloy structural steels. Post-weld heat treatment is often required.

According to EN 14700, the hardness values of the ferritic/martensitic weld metal are approx. 250 – 450 HB.

Special features:	stainless ("c"), impact-resistant ("p"), heat-resistant ("t"), good mechanical workability, as well as good high-temperature, thermal shock and crack resistance
Wear types:	Rolling impact wear with thermal shock, corrosion and erosion corrosion, grain sliding wear $\geq 500^\circ\text{C}$, flushing wear and liquid erosion

Fe8

These alloys have a carbon content $C = 0.2 - 2\%$. The weld metal is martensitic and contains 5 – 20 % Cr. The weld metal is air-hardening and, untreated, can only be machined by grinding. Preheating is usually performed prior to welding to improve crack resistance. It is suitable for applications with abrasive stress, also in combination with pressure and impact loads. Typical applications include steel mill rolls, dies, cutting tools, crusher and mill parts, mixers, etc.

According to EN 14700, the hardness values of the martensitic-carbide weld metal are approx. 50 – 65 HRC.

Special features:	abrasion-resistant ("g"), impact-resistant ("p"), heat-resistant ("t"), but moderate high temperature and thermal shock resistance
Wear types:	Impact wear with thermal shock, impact sliding wear, erosion \geq 500°C, fluid erosion

Fe9

This group includes the manganese hard steels with C \leq 1.2 % and 9 - 20 % Mn. In addition, alloying of up to 20% Cr is possible. In a welded condition, the weld metal has a hardness of 200 to 300 HV, but an increase in hardness to about 40 to 50 HRC is possible through work hardening (compression or impact stress), but this requires deformation of the material. The metal is also resistant to abrasion and has a high degree of toughness. The weld metal is not suitable for pure abrasive wear. It is used for crushing systems (hammers, beaters, crusher jaws) and excavator components (track links, teeth). The suitability for running wheels of cranes and rail vehicles is better than that of group Fe1 or Fe2. This alloy type is traditionally used for surface welding on rails. Post-processing is usually not carried out. It would require carbide tools. Do not overheat during grinding to prevent cracking. Welding should be carried out as cold as possible (interpass temperatures $T_z \leq 150^\circ\text{C}$), otherwise precipitation of grain boundary carbides and a decrease in toughness will occur.

According to EN 14700, the hardness values of the initially austenitic weld metal are approx. 200 -250 HB, after work hardening (forming by pressure or impact) the hardness can increase to 40 – 50 HRC.

Special features:	work hardenable ("k"), impact-resistant ("p"), rust-proof with addition of Cr ("c")
Wear types:	Impact wear, rolling wear, impact sliding wear

Fe10

The group of austenitic CrNiMn steels in the weld metal is tougher than the manganese hard steels of the Fe9 group. The lower work hardening of about 250 HV to approx. 450 HV is complemented by good corrosion resistance. The filler material is often applied as a buffer layer, but can also be used for wear-resistant surfacing. The weld metal is not heat treated and can be machined by cutting.

According to EN 14700, the hardness values of the initially austenitic weld metal are approx. 180 -200 HB, after work hardening (forming by pressure or impact) the hardness can increase to approx. 38 – 42 HRC.

Special features:	stainless ("c"), work hardenable ("k"), impact-resistant ("p"), scale-resistant ("z"), high resistance to cracking, high temperatures and thermal shock
Wear types:	Impact wear, rolling wear and erosion

Fe11

The group of austenitic CrNi welding consumables are equivalent to the high-alloy, stainless and heat-resistant welding consumables used for joint welding. Predominantly consumables with 29%Cr / 9%Ni and a ferrite content of about 40% in the weld metal are classified here. The austenitic consumables from group Fe11 have increased from about 200 HB to approx. 400 HB work hardenable. The build-up welding can be carried out on similar steels, on Cr steels and structural steels; the corrosion resistance and toughness of the weld metal are very good. The weld metal can be machined. The 29/9 types in particular are suitable for surfacing and joint welding of steels that are difficult to weld; they are also preferred for welding buffer layers.

According to EN 14700, the hardness values of the austenitic weld metal are approx. 180 -220 HB.

Special features:	stainless ("c"), scale-resistant ("z"), partially non-magnetisable ("n"), high resistance to cracking, high temperatures and corrosion
Wear types:	Corrosion and cavitation

Fe13

The C content of up to 1.5% with possible Cr, Ni, Mo, B and Ti content produces a martensitic-austenitic weld metal with special carbide and possibly boride content, which ensure a very high degree of hardness and grinding resistance. The weld metal is particularly resistant to abrasive wear, even under high pressure.

It is mostly used in earthmoving and mining machinery, agricultural equipment and for the armoring of drilling rigs in geological exploration and civil engineering.

According to EN 14700, the hardness of the martensitic/austenitic/carbide weld metal is approx. 55 - 65 HRC.

Special features:	abrasion-resistant ("g"), high pressure but low impact resistance
Wear types:	Erosion

Fe14

The C content of 1.5 to 4.5% with a Cr content of 25 to 40% is equivalent to high-carbon Cr steels. The weld metal obtains its hardness from the formation of carbides and is particularly resistant to abrasive wear, i.e. friction caused by mineral partners (earthmoving equipment, mining industry, ore plants, steel industry). In addition to chromium as a carbide former, only molybdenum is added in the Fe14 group. Heat treating the weld metal would not increase the hardness, while the only possible machining method is grinding.

According to EN 14700, the hardness of the martensitic/austenitic/carbide weld metal is approx. 40 – 60 HRC.

Special features:	abrasion-resistant ("g"), stainless ("c"), but moderate resistance to impacts, high temperature and thermal shock
Wear types:	Impact sliding wear, groove wear, grain sliding wear $\geq 500^{\circ}\text{C}$, flushing wear

Fe16

The C content of 4 – 8% with a Cr content of 10 - 40% produces an extremely hard carbide weld metal. The weld metal is particularly resistant to abrasive or abrasion wear, i.e. friction caused by earthmoving equipment, mining industry, ore plants, steel industry. In addition to chromium as a carbide former, other elements such as Mo, W, V and Nb are added to the Fe16 group. Heat treating the weld metal would not increase the hardness, while the only possible machining method is grinding.

According to EN 14700, the hardness of the martensitic/austenitic/carbide weld metal is approx. 60 – 70 HRC.

Special features:	abrasion-resistant ("g"), scale-resistant ("z"), but low resistance to impacts and thermal shock, cracks usually form in the weld metal
Wear types:	Impact sliding wear, groove wear, grain sliding wear $\geq 500^{\circ}\text{C}$

Ni2

This group includes nickel-based welding consumables with a higher molybdenum content. Various NiCrMo alloys are used as well as welding consumables with W supplement on occasion. The heat-resistant weld metal has high hot hardness, corrosion resistance and high temperature resistance. The weld metal ranges from 240 HB to approx. 350 to 550 HB work hardenable. The weld metal is used for example for forging hammers, dies, hot shear knives, etc.

According to EN 14700, the hardness values of the deposited metal are approx. 200 – 400 HB.

Special features:	stainless ("c"), work hardenable ("k"), impact-resistant ("p"), heat-resistant ("t"), scale-resistant ("z"), good resistance to high temperatures and thermal shock, good cracking resistance and mechanical workability
Wear types:	Impact wear, rolling-shock wear, thermal shock, grain sliding wear $\geq 500^{\circ}\text{C}$, impact-sliding wear even at high temperatures

Ni20

This group includes welding consumables with a nickel or nickel-boron-silicon matrix basis with embedded tungsten carbides, whereby the tungsten carbide type can vary. These welding consumables are characterised by excellent abrasion resistance, are resistant to cracking and offer good resistance to impacts, high temperatures and corrosion. The very high tungsten carbide content offers very good wear protection, especially against fine-abrasive media such as sand and is widely used in the extraction and processing of oil sand.

According to EN 14700, the hardness values of tungsten carbides are between approx. 1500 – 2800 HV and the values of the matrix are about 40 to 55 HRC.

Special features:	stainless ("c"), abrasion-resistant ("g"), heat-resistant ("t"), scale-resistant ("z"), good resistance to high temperatures and good cracking resistance
Wear types:	Gouging wear, grain sliding wear $\geq 500^{\circ}\text{C}$, impact sliding wear even at high temperatures

Co1 / Co2 / Co3

Cobalt-based products, which are also known as "stellites" also fall into this category. The Co1 type alloys are molybdenum reinforced cobalt-chromium alloys with a low carbon content. These weld metals have excellent heat resistance and stability, making them suitable for hot working tools. The materials are resistant to abrasive wear, cavitation, erosion and corrosion, making them suitable for liquid valve seats. They can also work harden to a high degree of hardness.

The alloys of type Co2 have a significantly higher hardness in a welded state than Co1 and are therefore much more resistant to abrasion, even across a wide temperature range. They are also resistant to cavitation and chemicals.

The Co3 type alloy has the highest carbon (C) content and a relatively high volume of hard materials (carbides). It is characterised by excellent resistance to abrasion and erosion by solid particles, although some compromises must be made in terms of toughness.

Special features:	Co1: stainless ("c"), work hardenable ("k"), heat-resistant ("t"), scale-resistant ("z") Co2 and Co3: heat-resistant ("t"), scale-resistant ("z"), stainless to a limited extent ("c") and edge-holding ("s")
Wear types:	Rolling-impact wear, impact-sliding wear even at high temperatures, corrosion, cavitation, groove wear (Co2 & Co3), grain sliding wear ($T > 500^{\circ}\text{C}$, Co1 & Co2)

Cu1

This group includes copper-based welding consumables (see also Section M). These are alloyed with Al and can be alloyed with Sn and/or Fe, but $Ni \leq 6\%$ and $Mn \leq 2\%$. The weld metal of the most commonly used aluminium bronzes contains 7 to 15% aluminium (Al). The homogeneous alloys, which consist of a solid solution, contain up to 8% Al. The heterogeneous alloys containing more than 8.5% Al are supplemented by multi-component bronzes with the addition of Fe, Ni, Mn and occasionally also Si. Because of their similar load-bearing capacity to tin bronze, aluminium bronzes are used as surfacing materials for plain bearing parts and also for corrosion-resistant cladding on steels, where as many layers as possible are welded on. The hardness of the usual CuAl welding consumables is normally approx. 120 to 300 HB.

According to EN 14700, the hardness values of the deposited metal of Cu1 alloys are approx. 200 – 450 HB.

Special features:	stainless ("c"), partially non-magnetisable ("n"), high resistance to corrosion, pressure and impacts, good cracking resistance and mechanical workability
Wear types:	Sliding wear and erosion corrosion

Cu2

This group includes copper-based welding consumables (see also Section M). These can be alloyed with Al, Sn and/or Fe, but $Ni \leq 6\%$ and $Mn \leq 15\%$. The weld metal of the most commonly used aluminium bronzes contains 5 to 15% aluminium (Al). The homogeneous alloys, which consist of a solid solution, contain up to 8% Al. The heterogeneous alloys containing more than 8.5% Al are supplemented by multi-component bronzes with the addition of Fe, Ni, Mn and occasionally also Si. Due to their high load-bearing capacity, the aluminium composite bronzes are used as surfacing materials for forming tools and also for ship propellers made of similar materials. The hardness of the usual CuAlMn welding consumables is usually up to 300 HB.

According to EN 14700, the hardness values of the deposited metal of Cu2 alloys are approx. 200 – 300 HB.

Special features:	stainless ("c"), partially non-magnetisable ("n"), high resistance to corrosion, pressure and impacts, good cracking resistance and mechanical workability
Wear types:	Sliding wear and erosion corrosion

OK 13Mn



OK 13Mn is an austenitic manganese steel electrode which work hardens under impact and compressive stresses. It is primarily used for surfacing and building up manganese steel components exposed to severe impact and moderate abrasion. Typical applications include crusher plates and rolls, cones and mantles of rotary crushers etc. The interpass temperature should be kept as low as possible.

Specifications	
Classifications	EN 14700 : E Fe9

Welding Current	AC, DC+
Alloy Type	Austenitic Mn steel
Coating Type	Lime Basic
Min AC OCV	65

Typical Tensile Properties			
Condition	Yield Strength	Tensile Strength	Elongation
ISO			
As Welded	480 MPa	780 MPa	20 %

Typical Charpy V-Notch Properties		
Condition	Testing Temperature	Impact Value
ISO		
As Welded	20 °C	70 J
As Welded	-20 °C	45 J
As Welded	-40 °C	35 J
As Welded	-60 °C	25 J

Typical Weld Metal Analysis %		
C	Mn	Si
1.08	12.2	0.7

Deposition Data					
Diameter	Current	Voltage	Efficiency (%)	Fusion time per electrode at 90° I max	Deposition Rate
3.2 x 450 mm	95-135 A	23 V	60 %	95 sec	1.1 kg/h
4.0 x 450 mm	130-180 A	23 V	60 %	109 sec	1.4 kg/h
5.0 x 450 mm	170-230 A	25 V	60 %	132 sec	1.8 kg/h

OK 14MnNi



Austenitic manganese steel electrode with nickel for surfacing and building up manganese steel components exposed to severe impact and moderate abrasion. The weld metal is less prone to embrittlement and cracking compared to plain austenitic manganese steel weld metal. It workhardens under compressive stresses. Applications include: crusher plates and rolls, cones and mantels of rotary crushers, rail points. The interpass temperature should be kept as low as possible.

Specifications

Classifications	EN 14700 : E Z Fe9
Approvals	DB : 82.039.08

Approvals are based on factory location. Please contact ESAB for more information.

Welding Current	AC, DC+
Alloy Type	Austenitic Mn steel
Coating Type	Zircon Basic
Min AC OCV	65

Typical Tensile Properties

Condition	Yield Strength	Tensile Strength	Elongation
ISO			
As Welded	440 MPa	690 MPa	30 %

Typical Charpy V-Notch Properties

Condition	Testing Temperature	Impact Value
ISO		
As Welded	20 °C	100 J
As Welded	-20 °C	80 J
As Welded	-80 °C	45 J
As Welded	-120 °C	25 J

Typical Weld Metal Analysis %

C	Mn	Si	Ni
0.67	13.2	0.2	3.0

Deposition Data

Diameter	Current	Voltage	Efficiency (%)	Fusion time per electrode at 90% I max	Deposition Rate
3.2 x 450 mm	100-160 A	30 V	54 %	90 sec	1.5 kg/h
4.0 x 450 mm	130-210 A	30 V	54 %	105 sec	2.0 kg/h
5.0 x 450 mm	170-300 A	31 V	56 %	114 sec	2.9 kg/h

OK Toolrode 50



Electrode for surfacing hot working tools. Suitable for service temperatures up to about 550 °C and applications where toughness and good wear resistance are required. Typical applications include hot working blades and shears, punches and bottom dies. Preheating and interpass temperature should be minimum 200°C to avoid issues with cracking.

Specifications

Classifications	EN 14700 : E Z Fe3
Welding Current	AC, DC+
Alloy Type	High speed steel
Coating Type	Lime Basic
Min AC OCV	65

Typical Weld Metal Analysis %

C	Mn	Si	Cr	Nb	Co	W
0.32	0.9	1.1	1.8	0.8	2.1	7.9

Deposition Data

Diameter	Current	Voltage	Efficiency (%)	Fusion time per electrode at 90% I max	Deposition Rate
2.5 x 350 mm	70-110 A	22 V	65 %	53 sec	0.9 kg/h
3.2 x 350 mm	100-150 A	23 V	63 %	62 sec	1.3 kg/h
4.0 x 350 mm	130-190 A	23 V	63 %	75 sec	1.7 kg/h
5.0 x 350 mm	180-250 A	25 V	66 %	88 sec	2.2 kg/h

OK Toolrode 60



Hardfacing electrode of the high-speed steel for repair welding of cutting tools, drills, stamping machines etc. The weld metal obtains its maximum hardness by double tempering. Suitable for step welding. To avoid issues with cracking, the working temperature should be preferably 400-500°C.

Specifications

Classifications	EN 14700 : E Fe4
Welding Current	AC, DC+
Alloy Type	Tool steel
Coating Type	Lime Basic
Min AC OCV	65

Typical Weld Metal Analysis %

C	Mn	Si	Cr	Mo	V	W
0.93	1.4	1.4	4.7	7.3	1.60	1.39

Deposition Data

Diameter	Current	Voltage	Efficiency (%)	Fusion time per electrode at 90% I max	Deposition Rate
2.5 x 350 mm	80-110 A	23 V	55 %	67 sec	0.8 kg/h
3.2 x 350 mm	100-150 A	23 V	57 %	82 sec	1.1 kg/h
4.0 x 350 mm	120-190 A	25 V	58 %	97 sec	1.4 kg/h

OK Weartrode 30



Electrode depositing a low alloy steel for the protection of parts exposed to metallic wear. Typical application include rail and rail crossing section, cog wheels of cast steel, detail in rolling mills, e.g. grooved rollers and clutches. Weld metal hardness approximately 30 HRC.

Specifications

Classifications	EN 14700 : E Z Fe1
Approvals	DB : 82.039.07

Approvals are based on factory location. Please contact ESAB for more information.

Welding Current	AC, DC+
Alloy Type	Martensitic steel
Coating Type	Lime Basic
Min AC OCV	65

Typical Weld Metal Analysis %

C	Mn	Si	Cr
0.1	0.7	0.7	3.2

Deposition Data

Diameter	Current	Voltage	Efficiency (%)	Fusion time per electrode at 90% I max	Deposition Rate
2.5 x 350 mm	60-90 A	20 V	64 %	75 sec	0.7 kg/h
3.2 x 450 mm	100-140 A	21 V	66 %	88 sec	1.2 kg/h
4.0 x 450 mm	140-190 A	22 V	66 %	92 sec	1.7 kg/h
5.0 x 450 mm	190-260 A	23 V	68 %	86 sec	2.8 kg/h
6.0 x 450 mm	230-320 A	23 V	68 %	92 sec	3.7 kg/h

OK Weatrode 30 HD



High recovery electrode for cladding and hardfacing rails, rail points, crossings, wheel conveyors, rolls etc. Used in the same type of applications as OK Weatrode 30. Weld metal hardness approx. 30 HRC.

Specifications

Classifications	EN 14700 : E Fe1
Welding Current	AC, DC+
Alloy Type	Martensitic steel
Coating Type	Zircon Basic
Min AC OCV	65

Typical Weld Metal Analysis %

C	Mn	Si	Cr
0.1	0.8	0.7	3.0

Deposition Data

Diameter	Current	Voltage	Efficiency (%)	Fusion time per electrode at 90% I max	Deposition Rate
3.2 x 450 mm	110-180 A	26 V	67 %	66 sec	2.4 kg/h
4.0 x 450 mm	160-240 A	30 V	67 %	69 sec	3.4 kg/h
5.0 x 450 mm	230-330 A	42 V	68 %	73 sec	5.0 kg/h

OK Weartrode 35



This electrode is a hardfacing basic type yielding an as welded hardness of 300 HV. It combats metal to metal wear and slight abrasion. It is used mainly for surfacing worn train and tramway rails. Also for carbon manganese crossings. Other areas of use: Cog-wheels

Specifications

Classifications	EN 14700 : E Fe1
Welding Current	DC+
Ferrite Content	N/A
Alloy Type	C, Si, Mn, Cr
Coating Type	Basic

Typical Weld Metal Analysis %

C	Mn	Si	Cr
0.09	0.9	0.8	3.0

Deposition Data

Diameter	Current	Efficiency (%)	Fusion time per electrode at 90% I max	Deposition Rate
3.2 x 450 mm	110-140 A	77 %	84 sec	1.2 kg/h
4.0 x 450 mm	140-160 A	77 %	98 sec	1.6 kg/h
5.0 x 450 mm	180-200 A	77 %	100 sec	2.4 kg/h

OK Wearrode 40



OK Wearrode 40 is used in applications exposed to metal to metal wear. A common application is surfacing wear resistant dies operating at temperatures up to 400°C. OK Wearrode 40 provides a weld metal with minimum hardness level of 40 HRC, typical value is around 45 HRC.

Specifications

Classifications	EN 14700 : E Z Fe2
Welding Current	DC+
Alloy Type	C, Mn , Si, Cr, V
Coating Type	Basic

Typical Weld Metal Analysis %

Deposition Data

Diameter	Current	Efficiency (%)	Fusion time per electrode at 90% I max	Deposition Rate
3.2 x 450 mm	90-130 A	71 %	97 sec	1.1 kg/h
4.0 x 450 mm	160-180 A	67 %	112 sec	1.4 kg/h
5.0 x 450 mm	170-220 A	71 %	127 sec	2.0 kg/h

OK Weartrode 45



Heavy coated general purpose hardfacing electrode for worn parts providing a hardness level of approximately 45 HRC.

Specifications

Classifications	EN 14700 : E Z Fe3
Welding Current	DC+
Alloy Type	Martensitic
Coating Type	Basic

Typical Weld Metal Analysis %

C	Mn	Si	Cr
0.3	2.0	0.8	1.3

Deposition Data

Diameter	Current	Voltage	Efficiency (%)	Fusion time per electrode at 90% I max	Deposition Rate
3.2 x 450 mm	100-130 A	24 V	63 %	94 sec	1.1 kg/h
4.0 x 450 mm	130-180 A	26 V	60 %	105 sec	1.4 kg/h
5.0 x 450 mm	180-220 A	25 V	64 %	124 sec	1.9 kg/h

OK Weartrode 50



General purpose hardfacing electrode for repair welding worn parts on agricultural equipment, forestry tools, loading machines, etc. Transformers with low open circuit voltage can be used (>45 volt).

Specifications

Classifications	EN 14700 : E Z Fe2
Welding Current	AC, DC+
Alloy Type	Martensitic steel
Coating Type	Acid Rutile
Min AC OCV	45

Typical Weld Metal Analysis %

C	Mn	Si	Cr	Mo
0.46	0.4	0.5	6.0	0.5

Deposition Data

Diameter	Current	Voltage	Efficiency (%)	Fusion time per electrode at 90% I max	Deposition Rate
2.5 x 350 mm	60-120 A	28 V	46 %	49 sec	0.8 kg/h
3.2 x 350 mm	90-160 A	30 V	46 %	59 sec	1.2 kg/h
4.0 x 450 mm	125-210 A	33 V	48 %	82 sec	1.7 kg/h
5.0 x 450 mm	160-260 A	37 V	48 %	86 sec	2.6 kg/h

OK Weartrode 50 T



OK Weartrode 50 T is primarily used for surfacing objects that are exposed to impact, metal to metal and pressure in environments up to 400 °C i.e. dies, cog wheels, cutting edges and press tooling.

Specifications

Classifications	EN 14700 : E Z Fe8
-----------------	--------------------

Welding Current	DC+
Alloy Type	C, Mn, Si, Cr
Coating Type	Basic

Typical Weld Metal Analysis %

C	Mn	Si	Cr
0.20	0.6	0.3	12.7

Deposition Data

Diameter	Current	Efficiency (%)	Fusion time per electrode at 90% I max	Deposition Rate
2.5 x 350 mm	60-80 A	59 %	55 sec	0.9 kg/h
3.2 x 450 mm	90-110 A	71 %	80 sec	1.3 kg/h
4.0 x 450 mm	140-160 A	71 %	106 sec	1.6 kg/h

OK Weartrode 55



Heavy coated general purpose hardfacing electrode for worn parts where a hardness level of minimum 50 HRC is required.

Specifications

Classifications	EN 14700 : E Z Fe3
Welding Current	DC+
Alloy Type	Martensitic
Coating Type	Basic

Typical Weld Metal Analysis %

C	Mn	Si	Cr
0.5	0.6	1.4	5.7

Deposition Data

Diameter	Current	Voltage	Efficiency (%)	Fusion time per electrode at 90% I max	Deposition Rate
3.2 x 450 mm	100-130 A	23 V	65 %	72,8 sec	1.1 kg/h
4.0 x 450 mm	130-180 A	24 V	64 %	107 sec	1.4 kg/h
5.0 x 450 mm	180-220 A	24 V	64 %	126 sec	1.9 kg/h
6.0 x 450 mm	210-270 A	25 V	66 %	140 sec	2.5 kg/h

OK Weartrode 55 HD



A general purpose hardfacing electrode depositing a semi corrosion resistant martensitic steel with a hardness of about 57 HRC. The electrode is specially suitable for hardfacing parts exposed to different forms of abrasive and impact wear, e.g. farming equipment, forestry tools, loading machines and mixers.

Specifications

Classifications	EN 14700 : E Z Fe6
Welding Current	AC, DC+
Alloy Type	Martensitic steel
Coating Type	Lime Basic
Min AC OCV	65

Typical Weld Metal Analysis %

C	Mn	Si	Cr
0.67	0.7	0.7	10.4

Deposition Data

Diameter	Current	Voltage	Efficiency (%)	Fusion time per electrode at 90% I max	Deposition Rate
2.5 x 350 mm	75-110 A	23 V	67 %	62 sec	1.0 kg/h
3.2 x 450 mm	110-150 A	23 V	67 %	95 sec	1.4 kg/h
4.0 x 450 mm	145-200 A	24 V	67 %	107 sec	1.9 kg/h
5.0 x 450 mm	190-270 A	26 V	66 %	110 sec	2.8 kg/h

OK Weartrode 60



Electrode for hardfacing parts of dredgers, feed screws, crusher and tractor parts exposed to wear by stone, coal, sand, soil, etc. The weld metal presents a relatively good resistance to oxidation, also at elevated temperatures.

Specifications

Classifications	EN 14700 : E Z Fe2
Welding Current	AC, DC+
Alloy Type	Martensitic steel
Coating Type	Basic
Min AC OCV	65

Typical Weld Metal Analysis %

C	Mn	Si	Cr
0.80	0.4	4.5	2.0

Deposition Data

Diameter	Current	Voltage	Efficiency (%)	Fusion time per electrode at 90% I max	Deposition Rate
3.2 x 450 mm	100-140 A	23 V	68 %	87 sec	1.2 kg/h
4.0 x 450 mm	140-190 A	25 V	68 %	90 sec	1.8 kg/h

OK Weartrode 60 T



Electrode giving a weld metal with coarse chromium carbides in an austenitic matrix. Suitable for surfacing worn parts in earth-moving equipment, sand pumps, mixers, feed screws, dust extractors, crushers etc exposed to wear by coal, ores and other minerals. Also in corrosive environment and/or elevated temperature.

Specifications

Classifications	EN 14700 : E Z Fe14
Welding Current	AC, DC+
Alloy Type	Carbide rich steel
Coating Type	Rutile Basic
Min AC OCV	50

Typical Weld Metal Analysis %

C	Mn	Si	Cr
4.8	1.0	0.7	34.3

Deposition Data

Diameter	Current	Voltage	Efficiency (%)	Fusion time per electrode at 90% I max	Deposition Rate
2.5 x 350 mm	90-120 A	24 V	62 %	60 sec	1.2 kg/h
3.2 x 350 mm	115-170 A	24 V	62 %	85 sec	1.6 kg/h
4.0 x 450 mm	130-210 A	26 V	64 %	135 sec	2.0 kg/h
5.0 x 450 mm	150-300 A	26 V	64 %	140 sec	2.9 kg/h

OK Weartrode 62



A hardfacing electrode depositing a weld metal with a high volume fraction of fine carbides in a martensitic matrix. It is designed for protection of parts subjected to severe abrasion from rock, sand, cement, etc. Applications: Earth-drilling equipment. Hammers, scrapers, knives, conveyor screws, etc.

Welding Current	AC, DC+/-
Alloy Type	Carbide rich steel
Coating Type	Basic
Min AC OCV	45

Typical Weld Metal Analysis %

C	Mn	Si	Cr	V	Ti
2.9	0.4	1.9	6.2	5.2	4.9

Deposition Data

Diameter	Current	Voltage	Efficiency (%)	Fusion time per electrode at 90% I max	Deposition Rate
3.2 x 350 mm	100-150 A	17 V	60 %	110 sec	0.7 kg/h
4.0 x 350 mm	115-200 A	17 V	64 %	120 sec	1.0 kg/h

OK Weartrode 65 T



The electrode deposits a high density of wear resisting carbides in an austenitic matrix capable of resisting extreme conditions of abrasion up to 700 °C. Recovery approximately 220 %. Typical applications include exhaust fans, ash ploughs, conveyor screws and sinter plant components.

Specifications

Classifications	EN 14700 : E Fe16
Welding Current	DC+
Alloy Type	Austenitic iron
Coating Type	Special

Typical Weld Metal Analysis %

C	Mn	Si	Cr	Mo	V	Nb	W
6.0	0.7	1.9	24.5	6.6	0.8	5.4	1.7

Deposition Data

Diameter	Current	Voltage	Efficiency (%)	Fusion time per electrode at 90% I max	Deposition Rate
3.2 x 350 mm	150-170 A	22 V	72 %	132 sec	1.2 kg/h
4.0 x 350 mm	220-250 A	23 V	71 %	123 sec	2.0 kg/h

OK Autrodur 38 G M

A copper coated, low-alloyed solid GMAW wire used for hard facing and building up, giving a wear resistant weld metal with a hardness between 35-40 HRC. Used for repair and maintenance of e.g. tracks, rails, wheels, rolls, railcrossings, shafts, shovel teeth and other parts on digging machines, tools like dies etc.

Specifications

Classifications	EN 14700 : Fe2
Approvals	NAKS/HAKC : 1.2mm

Approvals are based on factory location. Please contact ESAB for more information.

Alloy Type	Low alloyed (0.7 C, 2 % Mn, 1 % Cr, 0.2 % Ti)
Shielding Gas	M12, M21, C1 (EN ISO 14175)

Typical Weld Metal Analysis %

C	Mn	Si	S	P	Cr	Ti
Shielding gas;80Ar/20CO2						
0.6	1.4	0.4	0.01	0.01	1.0	0.06
Shielding gas;CO2						
0.6	1.0	0.2	0.01	0.01	1.0	0.05

Typical Wire Composition %

C	Mn	Si	Cr	Ti
0.69	1.92	0.49	1.00	0.2

Deposition Data

Diameter	Current	Voltage	Wire Feed Speed	Deposition Rate
1.2 mm	120-350 A	20-33 V	2.7-12.4 m/min	1.5-6.6 kg/h

OK Autrodur 56 G M

A copper coated, low-alloyed solid GMAW wire used for hard facing and building up highly wear resistant layers on tools and machinery parts, driving rollers, digging tools etc. The hardness of the weld metal becomes 50-60 HRC.

Specifications

Classifications	EN 14700 : Fe8
------------------------	----------------

Alloy Type	Low alloyed (0.45 % C, 3 % Si, 9 % Cr)
Shielding Gas	M21, C1 (EN ISO 14175)

Typical Weld Metal Analysis %

C	Mn	Si	S	P	Cr
Shielding gas: CO2					
0.4	0.3	2.6	0.01	0.02	8.8
Shielding gas: 80Ar/20CO2					
0.4	0.3	2.7	0.01	0.02	9.0

Typical Wire Composition %

C	Mn	Si	Cr
0.44	0.4	3.02	9.24

Deposition Data

Diameter	Current	Voltage	Wire Feed Speed	Deposition Rate
1.0 mm	80-280 A	18-28 V	2.7-14.7 m/min	1.0-5.4 kg/h
1.2 mm	120-350 A	20-33 V	2.7-12.4 m/min	1.5-6.6 kg/h

OK Autrodur 58 G M

A copper coated, low-alloyed solid GMAW wire used for hard facing and building up highly wear resistant layers on machinery parts like shafts, feed screws, driving rollers, cutting tools, dies and other parts subjected to strong wear. Hardness of the weld metal becomes 50-60 HRC.

Specifications

Classifications	EN 14700 : ZFe8
------------------------	-----------------

Alloy Type	Low alloyed (1.1 % C, 2 % Mn, 1.8 % Cr, 0.2 % Ti)
Shielding Gas	M21, C1 (EN ISO 14175)

Typical Weld Metal Analysis %

C	Mn	Si	S	P	Cr	Ti
Shielding gas: CO2						
0.8	1.5	0.4	0.01	0.01	1.6	0.08
Shielding gas: 80Ar20CO2						
0.9	1.6	0.4	0.01	0.01	1.6	0.10

Typical Wire Composition %

C	Mn	Si	Cr
1.04	1.87	0.48	1.82

Deposition Data

Diameter	Current	Voltage	Wire Feed Speed	Deposition Rate
1.2 mm	120-350 A	20-33 V	2.7-12.4 m/min	1.5-6.6 kg/h

OK Tubrodur 13Cr G

A cored wire which produces a 13%-chromium alloy steel deposit used with M13, M21 or C1 shielding gas.

Specifications

Classifications	EN 14700 : T Z Fe7
------------------------	--------------------

Welding Current	DC+
Alloy Type	Martensitic stainless steel weld metal
Shielding Gas	M12, M13, M21, C1 (EN ISO 14175)

Typical Weld Metal Analysis %

C	Mn	Si	Ni	Cr	Mo	V	Nb
M21 shielding gas							
0.15	1.14	0.31	2.23	12.53	1.40	0.23	0.23

Recommended Welding Parameters

Wire Diameter	Current	Voltage
1.6 mm	200-260 A	28-30 V

OK Tubrodur 35 G M

A hardfacing cored wire for rebuilding and surfacing with C1 shielding gas.

Specifications

Classifications	EN 14700 : T Fe1
Welding Current	DC+
Alloy Type	Martensitic steel weld metal
Shielding Gas	C1 (EN ISO 14175)

Typical Weld Metal Analysis %

C	Mn	Si	Cr
C1 shielding gas			
0.21	1.40	1.10	1.47

Deposition Data

Diameter	Current	Voltage	Wire Feed Speed	Deposition Rate
1.6 mm	250-350 A	28-34 V	5.0-12.6 m/min	2.4-6.8 kg/h

OK Tubrodur 53 G M

A cored wire which produces a Cr-Mo-V-Co-W alloyed weld metal for hardfacing used with C1 shielding gas.

Specifications

Classifications	EN 14700 : T Fe3 DIN 8555 : MF3-50T
Welding Current	DC+
Alloy Type	Surfacing alloy Cr-Mo-V-Co-W
Shielding Gas	C1 (EN ISO 14175)

Typical Weld Metal Analysis %

C	Mn	Si	Cr	Mo	V	Co	W
C1 shielding gas							
0.33	1.14	0.94	1.76	0.44	0.40	2.03	8.17

Deposition Data

Diameter	Current	Voltage	Wire Feed Speed	Deposition Rate
1.6 mm	150-450 A	21-40 V	2.4-11.9 m/min	1.8-9.0 kg/h

OK Tubrodur 60 G M

A 5%Cr - 1%Mo alloyed metal cored wire for use with carbon dioxide shielding gas.

Specifications

Classifications	EN 14700 : T Z Fe2
	DIN 8555 : MF6-55GP

Welding Current	DC+
Alloy Type	5%Cr 1%Mo
Shielding Gas	C1 (EN ISO 14175)

Typical Weld Metal Analysis %

C	Mn	Si	Cr	Mo
0.67	0.78	0.71	5.33	1.00

Deposition Data

Diameter	Current	Voltage	Wire Feed Speed	Deposition Rate
1.2 mm	150-350 A	18-34 V	5.3-16.4 m/min	2.2-7.0 kg/h
1.6 mm	150-450 A	21-40 V	2.4-11.9 m/min	1.8-9.0 kg/h

OK Tubrodur 13Mn O/G

A self-shielded cored wire which may also be used with C1 shielding gas, intended for rebuilding 13% manganese steels.

Specifications	
Classifications	EN 14700 : T Fe9

Welding Current	DC+
Alloy Type	13% manganese steel weld metal
Shielding Gas	None, C1 (EN ISO 14175)

Typical Weld Metal Analysis %				
C	Mn	Si	Ni	Al
No shielding gas				
0.85	11.78	0.63	2.95	0.38

Deposition Data				
Diameter	Current	Voltage	Wire Feed Speed	Deposition Rate
1.6 mm	150-260 A	24-30 V	2.0-4.2 m/min	2.5-3.2 kg/h

OK Tubrodur 15CrMn O/G

A cored wire which produces a work-hardening austenitic weld metal with high wear and impact resistance. Used with C1 shielding gas or self-shielded.

Specifications

Classifications	EN 14700 : T Fe9
Approvals	DB : 82.039.10

Approvals are based on factory location. Please contact ESAB for more information.

Welding Current	DC+
Alloy Type	14% Mn 14%Cr steel weld metal
Shielding Gas	C1 (EN ISO 14175)

Typical Weld Metal Analysis %

C	Mn	Si	Ni	Cr	Mo	V
0.3	13.5	0.5	1.75	16.0	0.8	0.65

Deposition Data

Diameter	Current	Voltage	Wire Feed Speed	Deposition Rate
1.2 mm	150-250 A	28-37 V	6.5-21.5 m/min	3.3-7.2 kg/h
1.6 mm	200-330 A	24-33 V	5.0-12.0 m/min	3.7-8.0 kg/h

OK Tubrodur 30 O M

A self-shielded cored wire which gives a Cr Mn alloyed weld metal for semi-automatic hardfacing.

Specifications

Classifications	EN 14700 : T Z Fe1
Approvals	DB : 82.039.09

Approvals are based on factory location. Please contact ESAB for more information.

Welding Current	DC+
Alloy Type	Martensitic steel weld metal
Shielding Gas	None

Typical Weld Metal Analysis %

C	Mn	Si	Cr	Al
No shielding gas				
0.10	1.41	0.43	2.94	1.37

Deposition Data

Diameter	Current	Voltage	Wire Feed Speed	Deposition Rate
1.6 mm	150-300 A	25-36 V	5.0-12.6 m/min	2.4-6.8 kg/h
2.4 mm	250-550 A	26-40 V	2.5-9.0 m/min	3.7-11.4 kg/h

OK Tubrodur 35 O M

A self-shielded cored wire which gives a Cr-Ni-Mo alloyed weld metal for rail surface repair.

Specifications

Classifications	EN 14700 : T Z Fe3
------------------------	--------------------

Welding Current	DC+
Alloy Type	Surfacing alloy: martensitic steel weld metal
Shielding Gas	None

Typical Weld Metal Analysis %

C	Mn	Si	Ni	Cr	Mo	Al
0.14	1.10	0.28	2.23	1.04	0.48	1.5

Deposition Data

Diameter	Current	Voltage	Wire Feed Speed	Deposition Rate
1.2 mm	150-250 A	28-37 V	6.5-21.5 m/min	3.3-7.2 kg/h
1.6 mm	150-300 A	25-36 V	5.0-12.6 m/min	2.4-6.8 kg/h

OK Tubrodur 40 O M

A self-shielded cored wire depositing a Cr-Ni-Mo alloyed weld metal.

Specifications

Classifications	EN 14700 : T Z Fe2
Welding Current	DC+
Alloy Type	Martensitic steel weld metal
Shielding Gas	None

Typical Weld Metal Analysis %

C	Mn	Si	Ni	Cr	Mo	Al
No shielding gas						
0.14	1.59	0.62	0.55	4.64	0.49	1.55

Deposition Data

Diameter	Current	Voltage	Wire Feed Speed	Deposition Rate
1.6 mm	150-300 A	25-36 V	5.0-12.6 m/min	2.4-6.8 kg/h

OK Tubrodur 55 O A

A self-shielded Cr carbide cored wire.

Specifications

Classifications	EN 14700 : T Z Fe14
Welding Current	DC+
Alloy Type	Carbide-rich steel weld metal
Shielding Gas	None

Typical Weld Metal Analysis %

C	Mn	Si	Cr	Mo	V
3.6	0.88	0.53	22.5	3.5	0.5

Deposition Data

Diameter	Current	Voltage	Wire Feed Speed	Deposition Rate
1.6 mm	150-300 A	25-36 V	5.0-12.6 m/min	2.4-6.8 kg/h

OK Tubrodur 58 O/G M

A hardfacing cored wire which gives Hv 550 - 650. Can be used with C1 shielding gas or self-shielded.

Specifications

Classifications	EN 14700 : T Fe6
Welding Current	DC+
Alloy Type	Martensitic steel weld metal
Shielding Gas	None, C1 (EN ISO 14175)

Typical Weld Metal Analysis %

C	Mn	Si	Cr	Mo	Al
No shielding gas					
0.42	1.22	0.31	4.89	1.14	0.6

Deposition Data

Diameter	Current	Voltage	Wire Feed Speed	Deposition Rate
1.6 mm	200-300 A	28-36 V	7.0-12.6 m/min	2.4-5.5 kg/h

OK Tubrodur 200 O D

An 18-8-6 self-shielded cored wire for cladding and joining 13% Mn steels

Specifications

Classifications	EN 14700 : T Fe10
------------------------	-------------------

Welding Current	DC+
Alloy Type	Austenitic Cr-Ni-Mn weld metal
Shielding Gas	None

Typical Weld Metal Analysis %

C	Mn	Si	Ni	Cr
0.026	5.12	0.48	8.7	19.1

Deposition Data

Diameter	Current	Voltage	Wire Feed Speed	Deposition Rate
1.6 mm	150-450 A	21-40 V	2.4-11.9 m/min	1.8-9.0 kg/h
2.4 mm	250-550 A	26-40 V	2.5-9.0 m/min	3.7-11.4 kg/h

OK Tubrodur 12Cr S

A cored wire which produces a martensitic 12%-chromium alloy steel deposit with nitrogen addition. Used under flux in the submerged arc process.

Specifications	
Classifications	EN 14700 : T Fe7

Welding Current	DC+-
Alloy Type	Surfacing alloy: martensitic stainless steel weld metal

Typical Weld Metal Analysis %								
C	Mn	Si	Ni	Cr	Mo	V	N	Nb
OK Flux 10.33								
0.05	0.86	0.51	3.88	11.9	1.02	0.10	0.061	0.11

Deposition Data				
Diameter	Current	Voltage	Wire Feed Speed	Deposition Rate
3.0 mm	400-700 A	28-36 V	2.5-5.5 m/min	5.5-12.0 kg/h

OK Tubrodur 13Cr S

A cored wire which produces a 13%-chromium alloy steel deposit used with OK Flux 10.61.

Specifications

Classifications	EN 14700 : T Fe7
------------------------	------------------

Welding Current	DC+
Alloy Type	Surfacing alloy: martensitic stainless steel weld metal

Deposition Data

Diameter	Current	Voltage	Wire Feed Speed	Deposition Rate
3.0 mm	400-700 A	28-36 V	2.5-5.5 m/min	5.5-12.0 kg/h

OK Tubrodur 23Cr S

A cored wire for submerged arc welding which produces a 22%Cr 4%Ni 1%Mo weld metal used under flux in the submerged arc process.

Specifications

Classifications	EN 14700 : T Fe7
------------------------	------------------

Alloy Type	Surfacing alloy: martensitic stainless steel weld metal
-------------------	---

Typical Weld Metal Analysis %

C	Mn	Si	Ni	Cr	Mo
0.04	0.23	0.77	4.0	23.4	1.3

Deposition Data

Diameter	Current	Voltage	Wire Feed Speed	Deposition Rate
3.0 mm	400-700 A	28-36 V	2.5-5.5 m/min	5.5-12.0 kg/h

OK Tubrodur 35 S M

A hardfacing cored wire for rebuilding and surfacing using the submerged arc welding process with OK Flux 10.33.

Specifications

Classifications	EN 14700 : T Fe1
------------------------	------------------

Welding Current	DC+
Alloy Type	Martensitic steel weld metal

Deposition Data

Diameter	Current	Voltage	Wire Feed Speed	Deposition Rate
3.0 mm	400-700 A	28-36 V	2.5-5.5 m/min	5.5-12.0 kg/h
4.0 mm	500-900 A	28-34 V	2.0-5.0 m/min	6.5-12.5 kg/h

OK Tubrodur 40 S M

A tubular hardfacing wire for rebuilding and surfacing using the submerged arc welding process.

Specifications	
Classifications	EN 14700 : T Z Fe1

Welding Current	DC+
Alloy Type	Martensitic steel weld metal

Typical Weld Metal Analysis %				
C	Mn	Si	Cr	Mo
OK Flux 10.71				
0.15	1.14	0.51	4.07	0.77

Deposition Data				
Diameter	Current	Voltage	Wire Feed Speed	Deposition Rate
3.0 mm	400-700 A	28-36 V	2.5-5.5 m/min	5.5-12.0 kg/h
4.0 mm	500-900 A	28-34 V	2.0-5.0 m/min	6.5-12.5 kg/h

OK Tubrodur 58 S M

A tubular hardfacing wire for rebuilding and surfacing using the submerged arc welding process.

Specifications

Classifications	EN 14700 : T Fe6
------------------------	------------------

Welding Current	DC+
------------------------	-----

Alloy Type	Martensitic steel weld metal
-------------------	------------------------------

Typical Weld Metal Analysis %

C	Mn	Si	Cr	Mo
OK Flux 10.71				
0.45	1.61	0.68	5.2	1.25

Deposition Data

Diameter	Current	Voltage	Wire Feed Speed	Deposition Rate
3.0 mm	400-700 A	28-36 V	2.5-5.5 m/min	5.5-12.0 kg/h

OK Flux 10.33

Agglomerated fluoride-basic flux designed primarily for surfacing of continuous casting rollers, using cored wires with single- or twin-arc technique with oscillating procedure. OK Flux 10.33 can also be used for hot strip mill roller tool steel overlays with a stringer bead procedure as well as for a variety of low alloy steel build-up filler metals. The flux has excellent slag removal and can tolerate high interpass temperatures.

Specifications	
Classifications	EN ISO 14174 : S A FB 2 56 53 DC
Slag Type	Fluoride-basic MgO-CaF ₂ -Al ₂ O ₃ -SiO ₂
Alloy Transfer	Non-alloying
Density	nom: 1.1 %
Basicity Index	nom: 2.9 %

OK Flux 10.96

A neutral, agglomerated chromium alloying flux for hardsurfacing purpose producing a weld metal with a hardness of about 35 HRC with a mild steel electrode.

Specifications

Classifications	EN ISO 14174 : S A GS 3 Cr3 DC
Slag Type	Magnesium-silicate SiO ₂ -MgO-Al ₂ O ₃ -Cr
Alloy Transfer	Chromium alloying
Basicity Index	nom: 0.7

Flux Consumption

Volts	kg Flux / kg Wire DC+	kg Flux / kg Wire AC
30 V	0.7 kg	0.6 kg
34 V	0.9 kg	0.8 kg
38 V	1.2 kg	1.0 kg

Conditions : Dimension 4.0 mm , Amps 580 A , Travel Speed 33 m/h

OK Flux 10.97

An agglomerated Chromium and Manganese alloying flux for hardsurfacing purpose producing a weld metal with a hardness of about 35 HRC with a mild steel electrode.

Specifications	
Classifications	EN ISO 14174 : S A AB 3 Cr1 Mn2 DC
Slag Type	Aluminate-basic Al ₂ O ₃ -CaO-MgO-Cr-Mn
Alloy Transfer	Chromium and Manganese alloying
Density	nom: 1.1 kg/dm ³
Basicity Index	nom: 1.4



OK Band 11.84

A welding strip designed for surfacing using the electroslag strip cladding process.

Alloy Type	7Cr - Mo - W - with higher C content
-------------------	--------------------------------------

Typical Wire Composition %						
C	Mn	Si	Ni	Cr	Mo	W
0.35	1.18	0.22	0.5	6.5	1.7	1.8



OK Band 430

OK Band 430 is a 17Cr welding strip designed for surfacing using the submerged arc welding and electroslag processes. The strip is used mainly for R+M applications. In combination with OK Flux 10.07 is giving a weld metal with 14Cr-4Ni-1Mo and a hardness of 370-420 HB.

Specifications

Classifications	EN ISO 14343-A : B 17
------------------------	-----------------------

Alloy Type	17Cr
-------------------	------

Typical Wire Composition %

C	Mn	Si	Cr
0.04	0.4	0.4	17.0

OK Flux 10.07

Neutral, agglomerated, nickel- and molybdenum alloying flux, specially designed for strip cladding with a 17Cr-strip, producing a weld metal with 14Cr-4Ni-1Mo and a hardness of 370-420 HB. Can also be used for cladding with a 17Cr-wire producing the same weld metal.

Specifications

Classifications	EN ISO 14174 : S A GS 3 Ni4 Mo1 DC
------------------------	------------------------------------

Welding Current	1000 A
Slag Type	Calcium silicate SiO ₂ -MgO-Al ₂ O ₃ -(CaF ₂)
Alloy Transfer	Nickel and molybdenum alloying
Density	nom: 1.0 kg/dm ³
Basicity Index	nom: 1.0

Flux Consumption

Volts	kg Flux / kg Wire DC+
26 V	0.65 kg
28 V	0.65 kg

Conditions : Dimension 60 x 0.5 mm , Amps 750 A , Travel Speed 7 m/h

Classifications	Wire
Wire	SFA/AWS - EN ISO
OK Band 430	14343-A:B 17

Typical Weld Metal Analysis %

C	Mn	Si	S	P	Ni	Cr	Mo
OK Band 430 3rd layer							
0.05	0.15	0.6	0.01	0.02	4.0	13.0	1.0

OK Flux 10.10

High basic, all mineral, agglomerated flux designed for electro slag strip surfacing. The flux is particularly suitable for strip cladding with stainless strip of the Cr-, Cr-Ni- and Cr-Ni-Mo-steel types, with or without Nb.

Specifications	
Classifications	EN ISO 14174 : ES A FB 2B 56 44 DC
Welding Current	1700 A (60 x 0.5 mm strip)
Slag Type	Fluoride basic CaF ₂ -Al ₂ O ₃
Alloy Transfer	Moderately silicon alloying
Density	nom: 1.0 kg/dm ³
Basicity Index	nom: 4.0

Flux Consumption	
Volts	kg Flux / kg Wire DC+
25 V	0.5 kg

Conditions : Dimension , Amps 1250 A , Travel Speed 9 m/h

Classifications	Wire	Weld Metal
Wire	SFA/AWS - EN ISO	AWS - As Welded
OK Band 309L ESW	14343-A:B 22 11 L	A5.39: ESCLAD1-EQ309L(Mod)/308L
OK Band 309L Mo	A5.9:EQ309L Mo (Mod) 14343-A:B 21 13 3 L	A5.39: ESCLAD1-EQ309L Mo(mod)/316L
OK Band 309L Nb ESW	14343-A:B 22 12 L Nb	A5.39: ESCLAD1-EQ309L(mod)/347
OK Band 430	14343-A:B 17	A5.39: ESCLAD2-EQ430(mod)/430

Approvals	
Wire	VdTÜV
OK Band 309L Nb ESW	•

Typical Weld Metal Analysis %									
C	Mn	Si	S	P	Ni	Cr	Mo	Cu	N
OK Band 309L ESW 1st layer									
0.03	1.2	0.4	0.001	0.002	10.0	19.0	0.2	0.1	0.05
OK Band 309L ESW 2nd layer									
0.02	1.2	0.5	0.001	0.002	11.0	20.0	0.2	0.1	0.05
OK Band 309L Mo 1st layer									
0.02	1.1	0.4	0.001	0.008	12.5	18.0	2.8	0.1	0.04
OK Band 309L Mo 2nd layer									
0.02	1.3	0.5	0.001	0.008	13.0	19.0	3.0	0.1	0.04
OK Band 309L Nb ESW 1st layer									
0.03	1.3	0.5	0.001	0.01	10.0	19.0	0.1	0.1	0.05
0.02	1.2	0.4	-	-	10.0	18.5	0.2	-	0.04
OK Band 309L Nb ESW 2nd layer									
0.02	1.3	0.5	-	-	11.0	20.5	0.1	-	0.05
OK Band 430 1st layer									
0.06	0.3	0.6	0.005	0.03	0.2	13.3	0.1	0.2	-
OK Band 430 2nd layer									
0.05	0.3	0.6	0.005	0.03	0.2	15.2	0.1	0.2	-

OK Flux 10.10

Typical Weld Metal Analysis %

	FN WRC-92	O
Nb		
OK Band 309L ESW 1st layer		
-	4	0.02
OK Band 309L ESW 2nd layer		
-	7	0.02
OK Band 309L Mo 1st layer		
-	6	-
OK Band 309L Mo 2nd layer		
-	8	-
OK Band 309L Nb ESW 1st layer		
0.4	4	-
0.5	7	-
OK Band 309L Nb ESW 2nd layer		
0.4	9	-

A close-up photograph of a metal component, possibly a part of a machine or engine. The image shows several circular holes of varying sizes, some of which appear to be bolt holes. The surface of the metal is heavily textured and shows signs of wear, including scratches and a rough, granular appearance. The lighting is dramatic, with strong highlights and deep shadows, emphasizing the metallic texture and the geometry of the holes. The overall color palette is dominated by shades of grey and black, with a yellowish-green tint in some areas.

Repair & Maintenance



ALUMINIUM STICK ELECTRODES (SMAW)	9-3
OK AlMn1	9-3
OK AlSi5	9-4
OK AlSi12	9-5
OTHER	9-6
OK GPC	9-6
OK Ni-CI	9-7
OK NiFe-CI	9-8
OK NiFe-CI-A	9-9
OK NiCu 1	9-10
Nicore 55	9-11

OK AIMn1



Covered electrode suitable for welding of Mn-alloyed aluminium and aluminium alloys containing up to 3 % Mg, e.g. EN AW-3103, 3207, 3003, 5005.

Specifications

Classifications	EN ISO 18273 : AIMn1
Welding Current	DC+
Alloy Type	Aluminium alloy AIMn1
Coating Type	Chloride and Fluoride Salt

Typical Weld Metal Analysis %

Mn	Si	Al	Fe
1.3	0.1	98.1	0.3

Deposition Data

Diameter	Current	Voltage	Efficiency (%)	Fusion time per electrode at 90% I max	Deposition Rate
2.4 x 350 mm	50-90 A	25 V	41 %	24 sec	0.51 kg/h
3.2 x 350 mm	70-120 A	21 V	89 %	23 sec	1.74 kg/h

OK AISi5



Covered electrode suitable for welding of AlMgSi-alloys e.g. EN AW 6060/6063, 6005, 6201 etc. Also suitable for welding of AISi5Cu- and AISi7Mg-castings.

Specifications

Classifications	EN ISO 18273 : AISi5
------------------------	----------------------

Welding Current	DC+
Alloy Type	Aluminium-silicon alloy, AISi5
Coating Type	Chloride and Fluoride Salt

Typical Weld Metal Analysis %

Si	Al	Fe
4.9	94.9	0.2

Deposition Data

Diameter	Current	Voltage	Efficiency (%)	Fusion time per electrode at 90% I max	Deposition Rate
2.4 x 350 mm	50-90 A	25 V	37 %	24 sec	0.45 kg/h
3.2 x 350 mm	70-120 A	23 V	47 %	27 sec	0.8 kg/h

OK AISi12



Covered electrode suitable for welding of aluminium castings of AISi-, AISiMg- and AISiCu-types. Also possible to use as filler material in gas welding.

Specifications

Classifications	EN ISO 18273 : AISi12
Welding Current	DC+
Alloy Type	Aluminium-silicon alloy, AISi12
Coating Type	Chloride and Fluoride Salt

Typical Weld Metal Analysis %

Si	Al	Fe
12.4	87.4	0.2

Deposition Data

Diameter	Current	Voltage	Efficiency (%)	Fusion time per electrode at 90% I max	Deposition Rate
2.4 x 350 mm	50-90 A	23 V	42 %	23 sec	0.54 kg/h
3.2 x 350 mm	70-120 A	23 V	45 %	30 sec	0.69 kg/h

OK GPC



OK GPC is designed for gouging, cutting and piercing mild and alloyed steel, cast iron and non-ferrous metals with the exception of pure copper, using standard welding equipment. The electrode can be used in a wide variety of applications, e.g. for bevelling, for preparation of cracked areas before welding, for back-gouging of root runs.

Welding Current	AC, DC-
Min AC OCV	65

Deposition Data		
Diameter	Current	Voltage
2.5 x 350.0 mm	100-120 A	43 V
3.2 x 350.0 mm	130-180 A	43 V
4.0 x 350.0 mm	170-230 A	48 V
5.0 x 450.0 mm	230-300 A	48 V

OK Ni-CI



OK Ni-CI is a nickel cored electrode for joining normal grades of cast iron, such as grey-, ductile- and malleable irons. It is also suitable for rectification and repair of these grades and for joining them to steel. Deposition is done on cold or slightly preheated cast iron. Weld metal is well machinable. Typical applications are repair of cast iron parts such as cracks in engine blocks, pump housings, gear boxes, frames as well as foundry defects.

Specifications

Classifications	SFA/AWS A5.15 : ENi-CI EN ISO 1071 : E C Ni-CI 3
Welding Current	AC, DC+-
Alloy Type	Ni-base alloy
Coating Type	Basic Special high graphite
Min AC OCV	50

Typical Weld Metal Analysis %

C	Mn	Si	Ni	Al	Cu	Fe
1.0	0.2	0.3	93.5	0.1	0.3	4.5

Deposition Data

Diameter	Current	Voltage	Efficiency (%)	Fusion time per electrode at 90° max	Deposition Rate
2.5 x 300 mm	55-110 A	21 V	71 %	46 sec	0.9 kg/h
3.2 x 350 mm	80-140 A	20 V	68 %	66 sec	1.2 kg/h
4.0 x 350 mm	100-190 A	19 V	70 %	71 sec	1.7 kg/h

OK NiFe-CI



A nickel-iron electrode for welding normal grades of cast iron and for joining them to steel. Can be used for malleable nodular cast iron and alloy cast iron. It has a special iron jacketed Ni core wire, which gives the electrode much improved current carrying capacity compared to electrodes with a homogeneous core wire. The electrode produces a weld metal stronger and more resistant to solidification cracking than the pure nickel electrode types. Typical applications are repair of pump bodies, heave machine sections, gear teeth, flanges and pulleys.

Specifications	
Classifications	SFA/AWS A5.15 : ENiFe-CI EN ISO 1071 : E C NiFe-1 3
Welding Current	AC, DC+
Alloy Type	Ni-Fe alloy
Coating Type	Basic Special high graphite
Min AC OCV	45

Typical Tensile Properties		
Condition	Yield Strength	Tensile Strength
ISO		
As Welded	380 MPa	560 MPa

Typical Weld Metal Analysis %						
C	Mn	Si	Ni	Al	Cu	Fe
0.9	0.6	0.5	53	0.4	0.9	44

Deposition Data					
Diameter	Current	Voltage	Efficiency (%)	Fusion time per electrode at 90% I max	Deposition Rate
2.5 x 300 mm	60-100 A	22 V	70 %	45 sec	0.8 kg/h
3.2 x 350 mm	80-150 A	23 V	70 %	56 sec	1.2 kg/h
4.0 x 350 mm	100-200 A	23 V	70 %	59 sec	1.6 kg/h

OK NiFe-CI-A



A nickel-iron cored electrode for joining normal grades of cast iron, such as grey-, ductile- and malleable irons. It is also suitable for rectification and repair of these grades and for joining them to steel. Deposition is done on cold or slightly preheated cast iron. The electrode produces a weld metal stronger and more resistant to solidification cracking than electrode type of pure nickel type. It is specially suited for high duty welds in ductile irons and for welding grey irons with increased contents of sulphur and phosphorous. Typical applications include repair of pump bodies, heavy machine sections, gear teeth, flanges and pulleys.

Specifications	
Classifications	SFA/AWS A5.15 : ENiFe-CI-A EN ISO 1071 : E C NiFe-CI-A 1
Approvals	CE : EN 13479 UKCA : EN 13479

Approvals are based on factory location. Please contact ESAB for more information.

Welding Current	AC, DC+-
Alloy Type	Ni-Fe alloy
Coating Type	Basic Special high graphite
Min AC OCV	50

Typical Weld Metal Analysis %					
C	Mn	Si	Ni	Al	Fe
1.5	0.8	0.7	51	1.4	46

Deposition Data				
Diameter	Current	Efficiency (%)	Fusion time per electrode at 90% I max	Deposition Rate
2.5 x 300 mm	55-75 A	70 %	70 sec	0.6 kg/h
3.2 x 350 mm	75-100 A	70 %	90 sec	0.9 kg/h
4.0 x 350 mm	85-160 A	70 %	70 sec	1.8 kg/h

OK NiCu 1



OK NiCu 1 is a nickel-copper cored electrode of monel type for welding normal grades of cast iron such as gray-, ductile- and malleable irons. Deposition is done on cold or slightly preheated material. The weld metal is well machinable and provides a good colour match to that of cast iron.

Specifications

Classifications	EN ISO 1071 : E C NiCu 1
Welding Current	AC, DC+-
Alloy Type	Nickel-copper alloy
Coating Type	Basic Special
Min AC OCV	45

Typical Weld Metal Analysis %

C	Mn	Ni	Cu	Fe
0.3	0.9	65	31	3

Deposition Data

Diameter	Current	Voltage	Efficiency (%)	Fusion time per electrode at 90% I max	Deposition Rate
2.5 x 300 mm	50-100 A	18 V	60 %	66 sec	0.6 kg/h
3.2 x 350 mm	60-125 A	18 V	65 %	97 sec	0.8 kg/h

Nicore 55

Nicore 55 is a composite metal cored wire for repair and joining of cast iron materials. The deposit, which is approximately 53% iron and 45% nickel, provides an excellent match for the coefficient of expansion exhibited by cast irons. Cracking is minimized because thermal stresses caused by the heat of welding are minimized. The light slag is easily removed enhancing visual weld inspection. The fact that this is a continuous electrode will improve the operating factor and minimize unnecessary stops and starts. This electrode can replace covered electrodes such as AWS ENiFe-CI or ENiFe-CI-A. It may be used for repair welds or for joining various types of cast irons. Cast irons may be welded to steel and other ferrous and non-ferrous materials with this product. The machinability of the weld deposit is comparable to the matching cover electrode. Substantial savings in weld metal deposition costs will be realized when replacing 55% nickel coated electrodes with Nicore 55. The deposition rate of this wire is more than twice that of a comparable coated electrode. The efficiency (approximately 97%) compared to that of coated electrodes (56% assuming 3" stub loss) is substantially greater. These two factors result in substantial savings in weld metal deposition costs. Because of the high deposition rate, the travel rate is very fast, resulting in lower heat input which is advantageous in welding cast irons.

Welding Current	DC+
Alloy Type	Cast iron
Shielding Gas	M12 (EN ISO 14175)

Typical Weld Metal Analysis %

C	Mn	Si	Ni	Al
1.04	0.23	0.71	45.3	0.01

Recommended Welding Parameters

Wire Diameter	Current	Voltage
1.2 mm	220-250 A	27-30 V

Reduce Costs Through One-Sided Welding

Ceramic backing for single-sided welding is opening up ever more applications. What began in the shipbuilding industry is now also becoming increasingly important for pressure vessel, tank, bridge and plant construction. The advantages of this process have been recognised in many welding companies. But where exactly are the special advantages of one-sided welding on ceramics?

Higher Deposition Rate Through Higher Welding Currents

The backing allows higher welding current to be used in the root layer. With the MAG process, for example, this means spatter-free welding when spray arc welding and the possibility of working with larger electrode diameters when MMA welding.

Simpler Seam Preparation

Wide recesses in the ceramics allow adaptation to varying air gap dimensions. Air gap widths of up to 10 mm can be compensated with some types of ceramics. This reduces the time required for aligning the metal plates.

No Need To Joint or Grind the Root Layer

Welding on ceramic backing creates a very good root quality, so that in contrast to the conventional method, the root remains part of the seam with a capping layer and the joint does not have to be ground out.

Further advantages: Reduced welding consumables consumption, reduced welding time.

Reliable Penetration and High Optical Seam Quality

Higher welding currents at the root layer result in deep penetration with a significantly reduced risk of bonding defects. The good root formation functions as a capping layer. After removing the backing, a glossy underside of the seam can be seen with a soft, notch-free transition into the base material.

Forming Effect on Underside of Seam

When ceramics on self-adhesive aluminium foil are used, a forming effect is created on the underside of the seam, which is particularly useful when processing stainless steels. The use of forming gases can often be omitted.

Economic viability

The combined effect of the mentioned process advantages contribute to reducing welding costs.

The savings potential lies particularly in the reduction of unproductive times such as grinding, jointing, pickling and straightening. Ceramic backing therefore enables a significant increase in the duty cycle for manual and MAG welding. In contrast, the material costs for the ceramics are comparatively modest. ESAB has a wide range of ceramic backing for almost every conceivable application. Whether for a K, X, V or HV seam, whether a circumferential seam, flat butt joint or T-joint, ESAB offers the most suitable ceramic.

Cross-Section Models

The product range includes flat ceramics with semicircular and trapezoidal recesses as well as cylindrical types of various diameters.

Flat Ceramics

Flat ceramics are offered in different designs. They are to be distinguished according to the type of recess for receiving the weld metal and any quantities of slag. Semicircular concave recesses are suitable for the use of welding consumables that do not have any or only slight amount of slag, such as solid wire electrodes and basic flux-cored wire. Flat ceramics with trapezoidal shaped recesses should be used in combination with more slag-bearing welding consumables such as rutile flux cored wire electrodes.

Cylindrical Ceramics

Cylindrical ceramics are especially suitable for DV and DHV seams on butt and T-joints. The ceramic diameter is selected according to the size of the air gap to be bridged and the opening angle of the seam. This ceramic type can be used for slag-free as well as slag-bearing filler metals.

Fastening Options

Self-adhesive aluminium foil has become established for fixing ceramic backing materials. The adhesive used is harmless to health when evaporated. The corresponding ceramic types with semicircular / concave trapezoidal recesses and cylindrical types can be found in the following product overview.

OK Backing Rectangular and Concave are provided with a centre line on both sides for easier positioning. Even longer sections can be taped without gaps, as these ceramics are provided with a groove/chamfer system. In addition, the protective paper is overlapped on one side to simplify handling.

Instructions for Use

Welding on ceramic pool protection requires a certain amount of practice. Neutral to drag torch position and a sufficiently large air gap must be observed, as well as careful welding parameter selection. ESAB offers you application-related product training courses in which you will learn about the full potential of welding on ceramic backing.

OK Backing Pipe 6

Type:	Round ceramic on self-adhesive tape	
Article Number:	212400TP06	
Length:	600 mm	
Colour:	Grey	
Fastening:	Self-adhesive Al foil	
Packaging:	Qty/box:	250 pcs
	Qty/palette:	14 000 pcs
	Weight/box:	13 kg

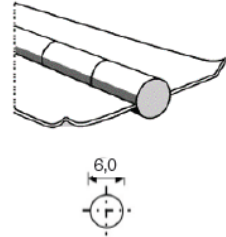

OK Backing Pipe 9

Type:	Round ceramic on self-adhesive tape	
Article Number:	212400TP09	
Length:	600 mm (Division: 24 x 25 mm)	
Colour:	Grey	
Fastening:	Self-adhesive Al foil	
Packaging:	Qty/box:	140 pcs
	Qty/palette:	7 870 pcs
	Weight/box:	12 kg

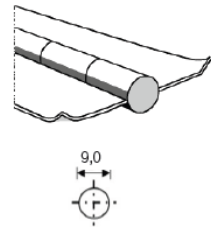

OK Backing Pipe 12

Type:	Round ceramic on self-adhesive tape	
Article Number:	212400TP12	
Length:	600 mm (Division: 24 x 25 mm)	
Colour:	Grey	
Fastening:	Self-adhesive Al foil	
Packaging:	Qty/box:	100 pcs
	Qty/palette:	5 600 pcs
	Weight/box:	13 kg

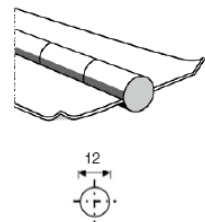

OK Backing Pipe 15

Type:	Round ceramic on self-adhesive tape	
Article Number:	212400TP15	
Length:	600 mm	
Colour:	Grey	
Fastening:	Self-adhesive Al foil	
Packaging:	Qty/box:	75 pcs
	Qty/palette:	4 200 pcs
	Weight/box:	14,5 kg

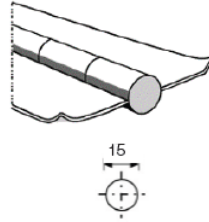

OK Backing Pipe 20

Type:	Round ceramic on self-adhesive tape	
Article Number:	212400TP20	
Length:	600 mm	
Colour:	Grey	
Fastening:	Self-adhesive Al foil	
Packaging:	Qty/box:	40 pcs
	Qty/palette:	1 600 pcs
	Weight/box:	14,5 kg

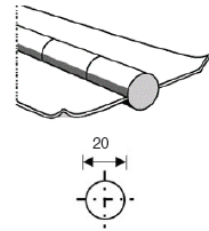

OK Backing Rectangular 13

Type:	Ceramic on self-adhesive aluminium strip	
Article Number:	212400TR13	
Length:	600 mm (Division: 24 x 25 mm)	
Colour:	Grey	
Fastening:	Self-adhesive Al foil	
Packaging:	Qty/box:	60 pcs
	Qty/palette:	3 360 pcs
	Weight/box:	15 kg

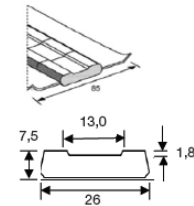

OK Backing Rectangular 16

Type:	Ceramic on self-adhesive aluminium strip	
Article Number:	212400TR16	
Length:	600 mm (Division: 24 x 25 mm)	
Colour:	Grey	
Fastening:	Self-adhesive Al foil	
Packaging:	Qty/box:	40 pcs
	Qty/palette:	2 240 pcs
	Weight/box:	16 kg

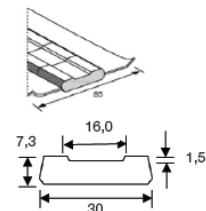

OK Backing Concave 6

Type:	Ceramic on self-adhesive aluminium strip	
Article Number:	2124000C06	
Length:	600 mm	
Colour:	Grey	
Fastening:	Self-adhesive Al foil	
Packaging:	Qty/box:	60 pcs
	Qty/palette:	3 360 pcs
	Weight/box:	15,5 kg

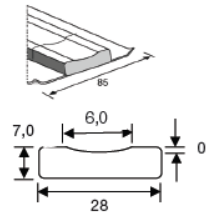

OK Backing Concave 10

Type:	Ceramic on self-adhesive aluminium strip	
Article Number:	2124000C10	
Length:	600 mm	
Colour:	Grey	
Fastening:	Self-adhesive Al foil	
Packaging:	Qty/box:	60 pcs
	Qty/palette:	3 360 pcs
	Weight/box:	15 kg

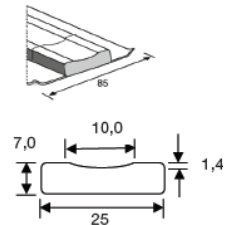

OK Backing Concave 13

Type:	Ceramic on self-adhesive aluminium strip	
Article Number:	212400TC13	
Length:	600 mm	
Colour:	Grey	
Fastening:	Self-adhesive Al foil	
Packaging:	Qty/box:	60 pcs
	Qty/palette:	3 360 pcs
	Weight/box:	14 kg

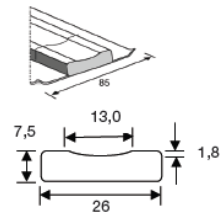

OK Backing Concave 16

Type:	Ceramic on self-adhesive aluminium strip	
Article Number:	2124000C16	
Length:	600 mm	
Colour:	Grey	
Fastening:	Self-adhesive Al foil	
Packaging:	Qty/box:	60 pcs
	Qty/palette:	3 360 pcs
	Weight/box:	15 kg

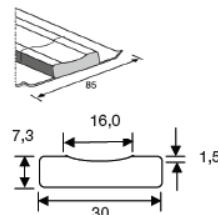

Storage and Processing Recommendations

Ceramic

Ceramic materials are not hygroscopic, Even in direct contact with water, they do not absorb any significant moisture (beading effect). It does not require any drying and is therefore suitable for use on construction sites. Ceramic backing materials can be stored under conditions similar to solid wire electrodes.

ESAB Backings: Tested Quality

ESAB's ceramic backings have been tested for their chemical neutrality with respect to the weld metal. Ether-free water-based adhesives are used for the ceramics on self-adhesive aluminium foil, which are not a danger to health. Any odour formation during welding on ESAB adhesive ceramics by the evaporating adhesive is harmless and not a danger to health (investigation by the Dutch TNO Institute). On request we would be happy to send you safety data sheets for the ceramic backing

Packaging for Coated Electrodes

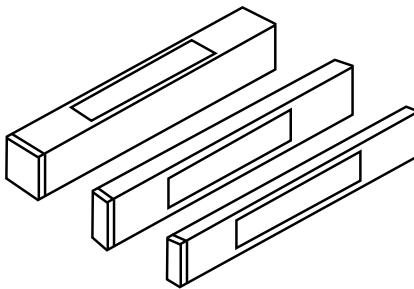

Standard Packaging

The standard electrode packaging consists of cardboard in PE shrink film for the inner package; the outer carton is also made of recyclable cardboard.

The amounts contained depend on:

1. Full package (cross-sectional square)
2. Half package ($\frac{1}{2}$ of the full package)
3. Quarter package ($\frac{1}{4}$ of the full package)

ESAB Part Number (suffix):

- 00 Full package cardboard in PE film
- 10 Half package cardboard in PE film,
6 packets/box

Packaging for Coated Electrodes



VacPac

The vacuum-packed VacPac protects electrodes in the box during transport.

VacPac saves time and money by simplifying storage and elimination of re-drying.

The vacuum-packed VacPac is:

1. Optional for stick electrodes for unalloyed steels and fine grain steels
2. For all electrodes for heat-resistant and high-strength steels (low alloy electrodes)
3. For high-alloy and nickel-based electrodes with diameters of $\varnothing \geq 4.0$ mm (½ - VacPac, type -G0)

ESAB Part Number (suffix):

- K0 Quarter package
(¼ VacPac, 9 packages/box)
- G0 Half package
(½ - VacPac, 6 packets/box)
- V0 Three quarter package
(¾ VacPac, 4 packets/box)

Mini VacPac

The vacuum-packed Mini VacPac is used for:

1. Type L for small diameter ($\varnothing 1,6 - 2,5$ mm) high alloyed stick electrodes, nickel-based electrodes, and stick electrodes for welding cast iron.
2. Type T for high-alloyed stick electrodes $\varnothing 3,2$ mm.
3. Type G for high-alloy and nickel-based electrodes from $\varnothing \geq 4.0$ mm.

ESAB Part Number (suffix):

- L0 Quarter package, ¼ - VacPac, 6 packets/box
- T0 Half package, ½ - VacPac, 3 packets/box
- G0 Half package, ½ - VacPac, 6 packets/box

Packaging for Coated Electrodes

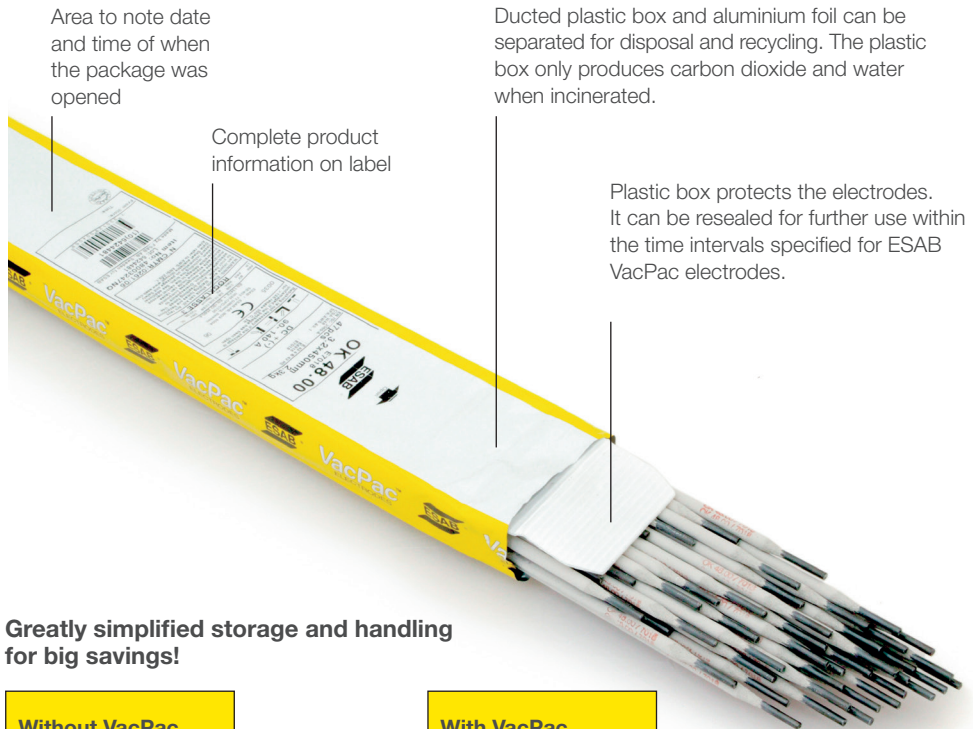

Greatly simplified storage and handling for big savings!

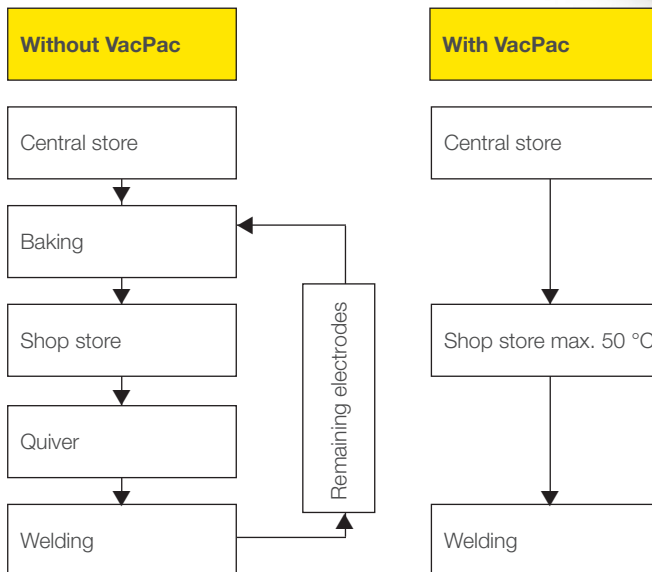

Packaging for Coated Electrodes



Plastic

The plastic packaging is for high-quality electrodes for repair and hardfacing use. It consists of resealable plastic quivers to remove electrodes as needed.

ESAB Part Number (suffix):

- 20 Full package, plastic quiver, resealable
- 30 Half package, Plastic quiver, resealable

Pipeweld Metal Canister (not shown)

The metal canister packaging is used exclusively for cellulose electrodes. Unlike other electrodes, cellulose electrodes must not be too dry or too wet, they are therefore “climate-controlled” in cans.

Suitable for rough construction site application and for steady supplies.

Pipeweld electrodes cannot be re-dried.

ESAB Part Number (suffix):

- 3640 Bottle packaging, depending on the diameter, 12-14 kg/box
- 3B40 Canned packaging with 20 kg/box



TIG Rods

Tig rods are packed in strong, air-tight fibre cylinders with a resealable plastic lid.

Strip Electrodes

OK Band welding strip is normally supplied in 50 kg coils, 60 x 0.5 mm. However, other widths such as 30 or 90 mm or larger coil weights are available on request.

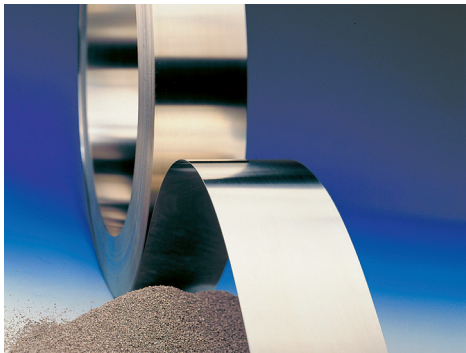



Paper Bag - 25 kg



Bucket - generally 25 kg



BigBag - 1,000 kg



BlockPac - 25 kg

Flux Packaging

ESAB fluxes are normally supplied in paper bags of 20 or 25 kg each. An inner bag of polythene provides extra protection from moisture pick-up from the surrounding atmosphere. ESAB fluxes for submerged arc welding can also be supplied in steel buckets of 25 kg. This packaging type is very strong and is used for demanding handling conditions. The resealable metal lid has a rubber seal to prevent the flux from absorbing moisture.

BigBag is intended for bulk usage. Fluxes, including OK Flux 10.71, are available in 1,000 kg content. BigBag offers six-fold security in terms of weight and has base dimensions of 85 x 85 cm. The height of a one tonne BigBag is 88 cm, enabling two bags to be stacked in a truck or container for transport.

BigBag is made of strong woven polypropylene material that has an internal multi-layered aluminium lining, keeping the flux "factory dry". There is a discharge spout with a diameter of 150 mm. It can easily be resealed so that only some of the flux is taken out at a time. BigBag has four strong straps allowing it to be lifted by a forklift truck or overhead crane and emptied directly into a flux container.

BlockPac™ provides full protection from moisture absorption during transport and storage. The bag is made of a laminated, multi-layer aluminium foil which creates a 100% moisture barrier. The flux is delivered in block shape with most of the bags having a low air pressure.

Fluxes delivered in BlockPac can be used without re-drying. Especially on hydrogen sensitive applications, such as welding of high strength steels thus significant handling times and costs can be saved on customer side. BlockPac allows more severe storage conditions and an unlimited shelf life as long as the foil is not damaged.



MARATHON PAC™ – Endless Feedability

For many customers, Marathon Pac™ bulk drums for MIG/MAG and FCAW are key in maximising production efficiency and quality in manual welding and especially in mechanised and robotic welding.

Marathon Pac can cut the time taken by spool changes and maintenance by almost 95%.

Marathon Pac comes in three sizes – the standard version, the jumbo version and the mini version – and is available for non- and low-alloyed MAG wires, stainless MIG wires, aluminium MIG wires, MAG-brazing wires, cored wires, and SAW wires up to 2 mm diameter.

In addition, there is an "endless version", which makes it possible to combine the content of a series of Marathon Pacs to form a continuous in-line supply source, thereby necessitating no stops whatsoever for wire exchange.

This is ideal for multi-robot stations. A special wire resistance welder is available from ESAB for this purpose. Availability and content weight are given in the table below.

Perfect Delivery to the Welding Head

The special coiling technique that is used when packing the drum ensures that the wire is never twisted or warped, which would otherwise cause arc wander. Welds are well positioned and perfectly straight. The unwinding process from the drum is automatic, so no separate de-coiling equipment is needed and no additional forces are required, like those that are needed when pulling a traditional revolving spool. This translates into a lower wear rate for the wire feeder.

Easy Recycling

Marathon Pac comes in cardboard drums that are fully recyclable. They can be folded flat after use to save on storage space.

Marathon Pac		
Marathon Pac Version	Wire Types	Filling Content
Standard - w x h: 513 x 830 mm	Non-/low-alloyed Stainless MAG-brazing Cored wires	250 kg (ø 0.8 mm : 200 kg) 250 kg (ø 0.8 mm : 200 kg) 200 kg depending on the wire type
Jumbo - w x h: 595 x 1000 mm	Non-/low-alloyed Stainless Aluminium Cored wires Submerged arc wires	500 kg (min. ø 1.0 mm) 500 kg (min. ø 1.0 mm) 141 kg depending on the wire type 450 kg (ø 2.0 mm)
Mini - w x h: 513 x 500 mm	Stainless	100 kg
Endless - 2x standard or jumbo	Non-/low-alloyed Stainless	2x 250 kg or 2x 500 kg 2x 250 kg or 2x 500 kg

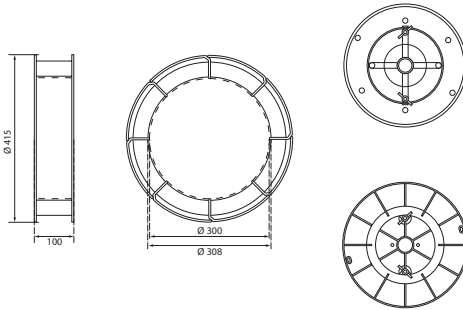

Spool 03

03-0	25 kg
------	-------

Random-wound wire basket. The spool is also suitable for coil holders with crossed arms. The empty basket is non-returnable.

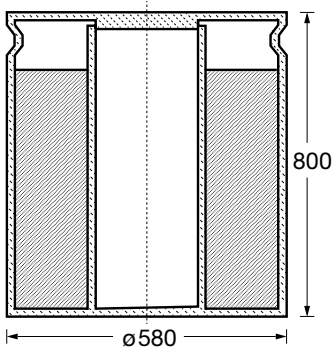

Spool 04

04-0	280 kg
------	--------

Random-wound pay-off drum. The empty spool is non-returnable.

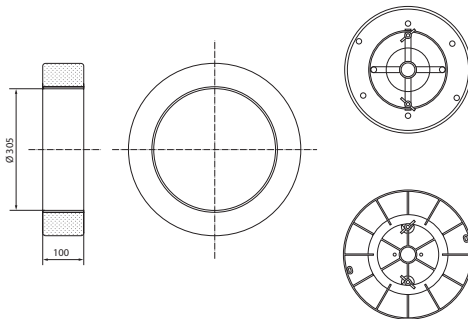

Spool 12

12-0	29 kg
------	-------

Layer-wound spool without cardboard former. The spool is not suitable for coilholders with crossed arms.

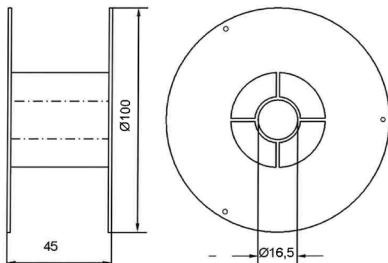

Spool 21

21-1	1 kg
21-5	0.5 kg

Layer wound plastic spool. Empty spool is non-returnable, but can be recycled.

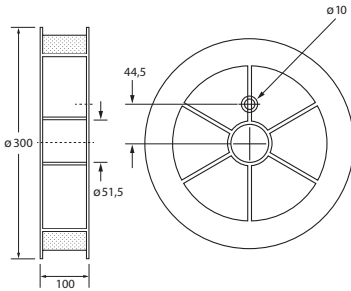

Spool 24

24-7	15 kg
------	-------

Plastic spool. Layer wound.
EN ISO 544: S 300

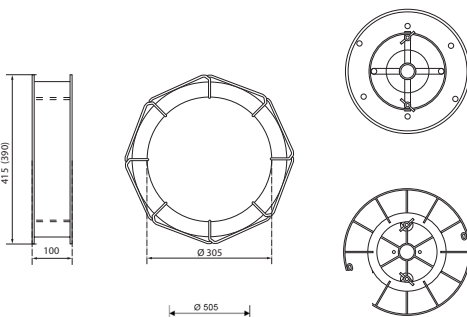

Spool 28/31 Eurospool

28-0	30 kg
28-1	25 kg

Precision-wound octagonal wire basket.
This spool is also suitable for coil holders with crossed arms. The empty basket is non-returnable, but fully recyclable.

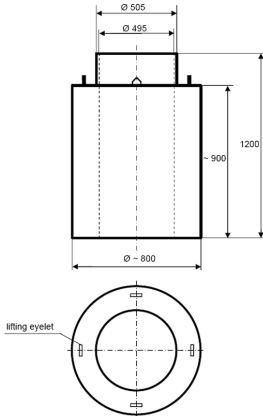

Spool 33

33-3	1000 kg
------	---------

Random wound spool with cardboard former. 4 lifting eyelets. Decoiling stand needed. All packaging materials not returnable but fully recyclable.

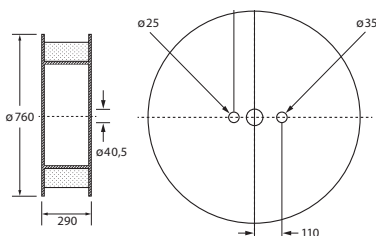

Spool 34

34-0	300 kg
------	--------

Random-wound wooden bobbin.
Decoiling stand required. The empty bobbin is non-returnable.

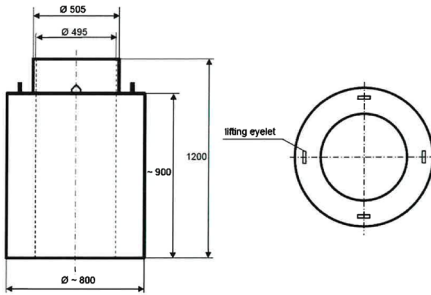

Spool 38

38-0	300 kg
38-2	250 kg

Random wound bulk pack. Typically called EcoCoil. Cardboard core. 4 lifting eyelets, Turn table required. All materials non-returnable, but can be recycled.

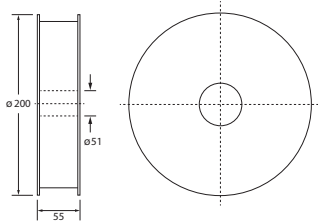

Spool 46

46-0	5 kg
46-2	2 kg

Plastic spool. Random wound EN ISO 544: S 200

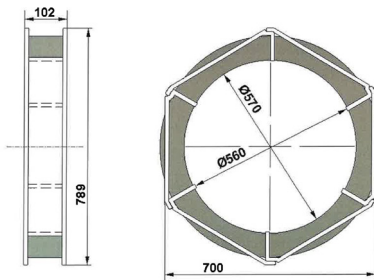

Spool 52

52-0	100 kg
------	--------

Random wound wire basket. Decoiling stand needed. Empty spool is non-returnable, but can be recycled. 75kg only for cored wire.

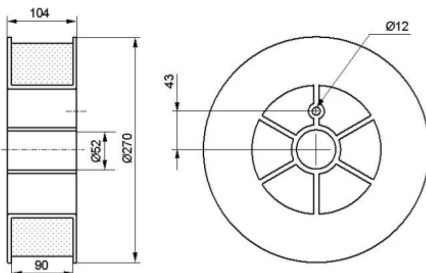

Spool 54

54-0	15 kg
------	-------

Precision layer wound plastic spool. Empty spool is non-returnable, but can be recycled.

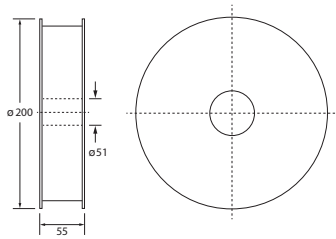

Spool 56

54-0	5 kg
------	------

Plastic spool. Layer wound
EN ISO 544: S 200

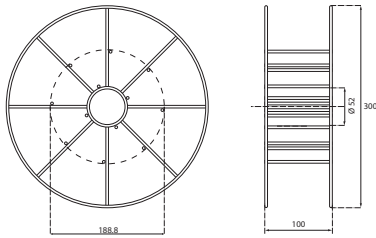

Spool 67

67-0	15 kg
67-3	18 kg
66-3	16 kg

Wire basket. Layer wound.
EN ISO 544: BS 300
67-copper-coated

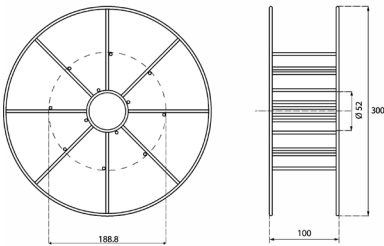

Spool 69

67-0	15 kg
66-3	16 kg

Wire basket. Layer wound.
EN ISO 544: KS 300
69-bare

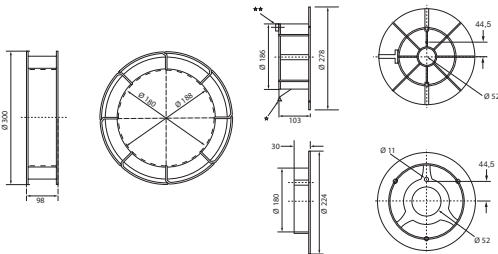

Spool 76

76-0	15 kg
76-1	18 kg
76-3	16 kg

Wire basket. Random wound.
EN ISO 544: B 300

Spool 77

77-0	15 kg
77-1	18 kg
77-3	16 kg

Wire basket. Layer wound.
EN ISO 544: B 300

• Adapter with one locking device: 0000 004 200
•• Adapter with an extra locking device: 2155 400 000

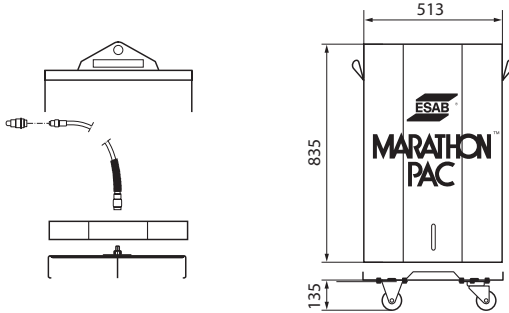

Spool 93 MARATHON PAC

93-0	200 kg
93-2	250 kg
93-X	catch weight

Accessories:

1. Wire conduit attachment
2. Wire conduits
3. Connector wire feed unit
4. Lifting yoke
5. Trolley

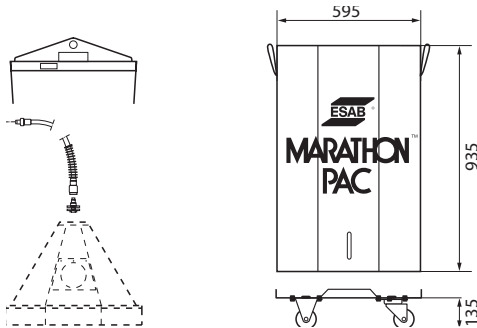

Spool 94 MARATHON PAC

94-0	475 kg
------	--------

Accessories:

1. Plastic hood
2. Quick connector
3. Wire conduits
4. Connector wire feed unit
5. Lifting yoke
6. Trolley

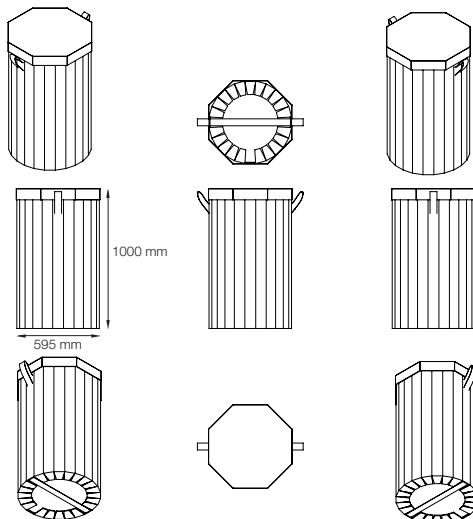

Spool 9A MARATHON PAC 2

9A-0	500 kg
9A-7	500 kg Endless

Accessories:

1. Plastic hood
2. Quick connector
3. Wire conduits
4. Connector wire feed unit
5. Lifting yoke
6. Trolley

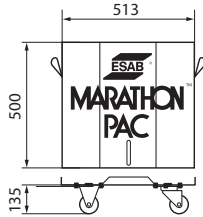
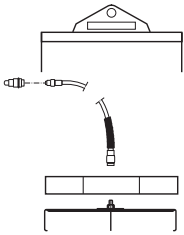

Spool 95 MARATHON PAC

95-0	100 kg
------	--------

Accessories:

1. Quick connector
2. Wire conduits
3. Connector wire feed unit
4. Lifting yoke
5. Trolley

Spool 96 MARATHON PAC

96-2	80 kg
------	-------

Cardboard drums with pre-twisted straight wire. Empty drum is non-returnable, but can be recycled.

Accessories:

1. Quick connector
2. Wire conduits
3. Connector wire feed unit
4. Lifting yoke
5. Trolley

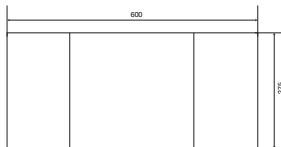
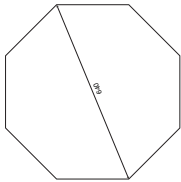
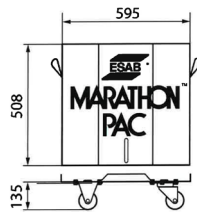
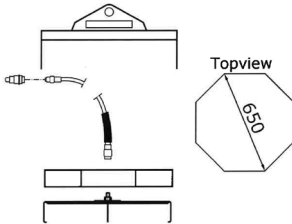

Spool 97 MARATHON PAC

97-2	25 kg
------	-------

Cardboard drums with pre-twisted straight wire. Empty drum is non-returnable, but can be recycled.

Accessories:

1. Quick connector
2. Wire conduits
3. Connector wire feed unit
4. Lifting yoke
5. Trolley

Spool 98

98-2	15 kg
98-3	18 kg
98-4	16 kg
98-6	6 kg
98-7	7 kg

EN ISO 544: BS 300

Layer-wound wire basket, plastic coated, which is used without adapter. Fitting to hub with diam. = 51 mm. Empty spool is recyclable.

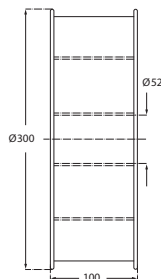
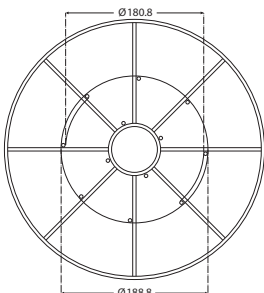

Storage Conditions

This guide provides information about optimal storage conditions for filler materials. Following the storage conditions will extend the durability of the filler materials.

There is no specific maximum time limit before which filler materials should be used. If stored under ideal storage conditions the time limit is extended and filler materials can be used many years after the date of supply. The reverse is also true i.e. tough and severe storage conditions shorten the durability of the products.

Products no longer covered by any warranty agreements should be thoroughly checked before use. If a decision is taken to use such products in production it will be the sole responsibility of the user.

Please refer to ESAB's standard Terms and Conditions of Sale.

General Handling

Handle all filler materials with care. Do not touch wires with bare hands, but use gloves.

UV Radiation

Long time exposure to UV radiation may bleach the label information. Therefore, avoid storing filler materials where they are exposed to UV radiation or direct sunlight.

Weld Quality

Porosity is formed by entrapment of discrete pockets of gas in the solidifying weld pool. The gas may originate from poor gas shielding, surface contaminants such as moisture, rust or grease, or insufficient deoxidants in the parent metal, electrode or filler wire. A particularly severe form of porosity called 'wormholes', is caused by gross surface contamination or welding with damp electrodes.

Characteristically, wormholes are elongated pores, which produce a herring bone appearance on the radiograph. Wormholes are indicative of a large amount of gas being formed, which is then trapped in the solidifying weld metal.

Hydrogen can contribute to cracks in welds or the HAZ (heat affected zone). Hydrogen, in combination with residual tensile stresses and crack sensitive steels, can cause cold cracking several hours or days after welding. High strength steels and weldments with high levels of residual tension are more sensitive to hydrogen cracking. For these applications, ESAB recommends using methods and filler metals that give low hydrogen levels together with adequate procedures for pre-heating, work temperature and post weld heat treatment.

It is important to note that there can be other significant sources of hydrogen, e.g. moisture from the atmosphere or from the material where processing or service history has left the steel with a significant level of hydrogen.

Hydrogen may also be derived from the surface of the material or the consumable, or from oil and paint etc.

The table below shows the relative humidity at which detrimental water condensation will form for a number of given differential temperatures. For example - if the relative humidity in the weld area is 70%, the base metal and electrode must be no colder than 5 °C below the air temperature to prevent moisture condensation.

This can happen when plates or electrodes come from a colder workshop, warehouse or from outside.

Dew point conditions versus relative humidity

Air Temp - Metal Temp* °C	Relative Humidity %	Air Temp - Metal Temp* °C	Relative Humidity %
0	100	12	44
1	93	13	41
2	87	14	48
3	81	15	36
4	75	16	34
5*	70*	18	30
6	66	20	26
7	61	22	23
8	57	24	21
9	53	26	18
10	50	28	16
11	48	30	14

The storage condition should be kept as stable as possible to avoid huge fluctuations in both moisture content level and temperature. Stable conditions minimise the risk of reaching the dew point at which condensation and formation of water occurs on packages etc. Hot air can contain significantly more water than colder air. As an example, air with a temperature of 15°C can contain up to 13 g/m³ water, while the corresponding amount at 25°C is 23.5g/m³ i.e. a massive increase of 78%. It is therefore much more critical to apply proper welding techniques in hot and humid welding conditions compared to when welding is done in somewhat colder conditions.

Disclaimer

While all reasonable efforts have been made to ensure the accuracy of the information contained in this handbook at the time of publication, ESAB gives no warranty with regard to its accuracy or completeness. It is the responsibility of the reader to check the accuracy of the information contained in this handbook, read product labels and equipment instructions and comply with current regulations. If the reader has doubt with regard to the proper use of any technology, they should contact the manufacturer or obtain alternative expert advice. ESAB accepts no responsibility or liability for any injury, loss or damage incurred as a result of any use or reliance upon the information contained in this handbook.

Information provided in this brochure are recommendations only. If followed, best possible storage conditions for the filler materials can be obtained and the lifetime maximised. This brochure shall not be treated as an official guarantee or statement from ESAB that recommended storage conditions have been fulfilled at all times for a filler material before it reaches an end user.

Nothing in this guide should be interpreted as attempting to supersede any warranty/guarantee terms and conditions, all of which shall take precedence over the terms of this brochure in the event of any conflict.

Disposal

When we develop our packaging solutions we always have sustainability and recyclability in mind. Any product, residue (slag), disposable container, liner or other packaging should be disposed of in an environmentally acceptable manner, in full compliance with federal and local regulations. Please address your local disposal company for prescribed disposal. Information on product and residues are given in the Safety Data Sheets available through www.esab.com.

ESAB electrodes can be supplied in different packaging types depending on the type and grade.

- Shrink film paper boxes are not completely airtight, so moisture from the surrounding atmosphere can enter the box and be picked up by the coating
- Plastic capsules have a lid and tape; moisture will permeate through at very low rates and be picked up by electrode coatings
- VacPac™ vacuum-sealed packaging provides complete protection against moisture provided the package is intact (vacuum maintained). If this is the case, no re-drying is needed before use.

If there is any doubt about whether an electrode is dry enough, it should be re-dried according to instructions shown on the label before use.

Storage Conditions

All covered electrodes are sensitive to moisture pick-up. High moisture contents in the coating can cause porosity or hydrogen cracking or reduced welding performance. However, the pick up rate will be very slow when stored under correct climatic conditions:

- 5 - 15°C: max 60% RH
- 15 - 25°C: max 50% RH
- >25°C: max 40% RH

At low temperatures, the humidity level can be maintained at low levels by ensuring a storage temperature of at least 10°C above the outside temperature. Cold packages should be allowed to reach ambient temperature before being opened.

At high temperatures, low humidity levels can be maintained by air dehumidification.

Actions Required in Case of a Deflated VacPac

- If the application is critical, always re-dry the electrodes before use

Re-Drying & Storage Time

- Low hydrogen covered basic electrodes should be re-dried before use whenever there are application requirements relating to weld metal hydrogen content and/or radiographic soundness (not needed for VacPac)
- Acid rutile stainless electrodes and all types of basic electrodes may produce pores in the weld metal if they have not been stored in sufficiently dry conditions. Re-drying the electrodes will restore their usability.
- Mild steel rutile and acid electrodes normally need no re-drying
- Cellulose electrodes must not be re-dried
- Electrodes, which are seriously damaged by moisture cannot be restored to their original condition by baking and should be discarded

Tin Cans

- Hermetically sealed package which allows welding without prior re-drying
- Tin cans do not provide any warning of leakage, so electrodes should always be checked concerning dryness prior to welding

Re-Drying Conditions

- Re-drying and holding temperatures and holding times are specified on the package label
- The re-drying temperature is the temperature in the bulk of the electrodes
- The re-drying time is measured from the point at which the re-drying temperature has been reached
- Do not stack electrodes more than four layers deep in the re-drying oven
- Re-drying is recommended up to a maximum of three times
- A summary of recommended re-drying conditions for ESAB electrodes is given in the table on the next page

Recommended re-drying temperatures, holding time two hours for OK and Exaton brands, B2 SC & B3 SC materials

80°C	120°C	200°C	250°C	300°C	350°C	350°C
OK NiCu 1	OK AlMn1	OK Femax 39.50	OK Femax 33.60	Exaton 22.9.3.LB	OK Femax 38.65	Exaton 19.9.LR
	OK AISi5		OK Femax 33.80	Exaton 22.12.HTR	OK Femax 38.95	Exaton 19.9.NbR
	OK AISi12	Exaton 22.9.3.LB		Exaton 25.10.4.LB		Exaton 19.12.3.LR
			Exaton 20.25.5.LCuR	Exaton 25.10.4.LR	Filarc 56 S	Exaton 22.9.3.LR
		Exaton Ni59			Filarc 75S	Exaton 23.12.2.LR
		Exaton Ni60	OK 67.13	OK 62.53	Filarc 76S	Exaton 24.13.LR
			OK 68.53	OK 68.82	Filarc 88S	Exaton 27.31.4.LCuR
		OK 13Mn	OK 68.55		Filarc 98S	
		OK 61.25	OK 69.33	OK Weartrode 40	Filarc 118	OK 61.20
		OK 61.35		OK Weartrode 45		OK 61.30
		OK 61.35 Cryo	OK 92.55	OK Weartrode 50	OK 48.00	OK 61.80
		OK 61.50	OK 94.35	OK Weartrode 50 T	OK 48.04	OK 61.81
		OK 61.85		OK Weartrode 60 T	OK 48.05	OK 61.86
		OK 63.35	OK Ni-1	OK Weartrode 65 T	OK 48.08	OK 63.20
		OK 63.85	OK NiCrFe-2		OK 48.15	OK 63.30
		OK 67.15		OK 94.25	OK 48.50	OK 63.34
		OK 67.45	OK Weartrode 62		OK 48.60	OK 63.41
		OK 67.55			OK 53.05	OK 63.80
		OK 67.75			OK 53.16 Spezial	OK 64.30
		OK 68.15			OK 53.68	OK 67.43
						OK 67.50
		OK 69.25			OK 53.70	OK 67.60
		OK 310Mo-L			OK 55.00	OK 67.70
					OK 67.43	
					OK 73.08	OK 68.17
		OK Ni-CI			OK 73.15	OK 68.81
		OK NiCrFe-3			OK 73.68	
		OK NiCrMo-3			OK 73.79	OK 14MnNi
		OK NiCrMo-13			OK 74.46	OK NiCrMo-5
		OK NiCu-7			OK 74.70	
		OK NiFe-CI			OK 74.78	OK Weartrode 30 HD
		OK NiFe-CI-A			OK 74.86 Tensitrode	OK Weartrode 35
					OK 75.75	
		OK Weartrode 30			OK 75.78	
		OK Weartrode 55 HD			OK B2 SC	
		OK Weartrode 60			OK 76.18	
					OK B3 SC	
		OK Tooltrode 50			OK 76.28	
		OK Tooltrode 60			OK 76.35	
					OK 76.96	
					OK 76.98	
					OK 78.16	
					Pipeweld 80 DH	
					Pipeweld 90 DH	
					Pipeweld 100 DH	

VacPac - No Re-Baking, No Holding Ovens, No Quivers.

MMA electrodes in a VacPac can be used straight from the package without the need to re-bake them and store them temporarily in holding ovens and quivers. Upon opening, fresh and dry electrodes are guaranteed when the vacuum is maintained.

Many of the un-alloyed and low alloyed electrodes have H4 or H5 classification which means the requirement of maximum 4.0 or 5.0 ml diffusible hydrogen/100g weld metal is met. Diffusible hydrogen classes are not applicable for stainless and high alloyed electrodes.

A low hydrogen class value is beneficial because it reduces the risk of hydrogen cracking and permits lower preheating and interpass temperatures to be applied during welding.

This leads to decreased energy consumption and thereby lower costs for a work site.

Some products have the letter "R" in the AWS classification. These products have a higher resistance against moisture re-absorption than electrodes without the "R" in the the AWS classification (maximum 0.4wt% after 9hrs exposure in a standard atmosphere of 26.7°C and 80%RH).

Electrodes in opened VacPac in an atmosphere exceeding 60%RH and 22°C should be re-dried after 8hrs for "R" classified electrodes, and after 4hrs for all other un-alloyed and low alloyed electrodes. For very critical applications and severe environments, a safe practice is to use heating quivers in order to prevent moisture pick up at the welding site. Depending on welding environment, the type of coating and hygroscopic properties, the application and welding positions, a re-drying operation may be required at a higher frequency to ensure that all requirements are met.

For austenitic stainless steel and nickel base electrodes, the main danger is too damp electrodes causing start porosity. If the safe exposure times are followed this issue can be prevented. The ferritic and ferritic martensitic grades can suffer from hydrogen cracking if too damp electrodes are used.

Simplified storage and handling for major savings

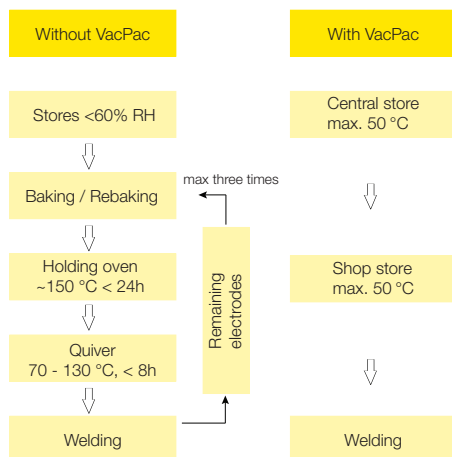

MIG/MAG Wires, TIG Rods, SAW Wires and ESW/SAW Strips

Solid MIG/MAG wires, TIG rods and SAW wires should be stored in dry conditions in original sealed undamaged packaging as supplied. Contact with water or moisture should be avoided. This could take the form of rain or the condensation of moisture on a cold wire. To avoid condensation, keep the wire in the original packaging and, if necessary, leave the wire to warm up to at least the ambient temperature before opening the package.

Other hydrogen-containing substances, like oil, grease and corrosion or substances that could absorb moisture must also be avoided on the surface of the wires. Spooled wire is supplied packed in plastic bags and partly used spools should be replaced into a plastic bag for storage to prevent surface contamination. Wire should be stored at ambient conditions of temperature and humidity, and dusty areas should be avoided when wire is not enclosed in some type of dust-protecting packaging or equipment.

TIG rods should be protected from dust and airborne contamination after removal from the packaging. The package for TIG rods consists of a rigid fibre tube with a plastic lid that can be closed again after breaking the sealing. The tube is PE coated and provides very good moisture protection. The package is also very stable and user friendly.

Marathon Pac™ bulk drum for MIG/MAG welding is designed for fast, efficient handling and ease of eventual recycling. VCI paper inside every drum and protective foil around each pallet protects the wire against moisture during transport and storage. Once empty, simply remove the lifting straps from the octagonal drum and fold it completely flat for easy, space saving storage until collection. Also note that Marathon Pac protects your welding wire from contamination.

Recommended conditions of storage for all solid wires, in their original packaging, are minimum temperature of 15-36°C and humidity of < 60% RH. Do not expose welding wires in storage to direct sunlight. Avoid direct contact with welding wire with bare or dirty hands.

Welding operators must keep strips as clean and protected as possible. This includes the careful and proper storage and handling of all stock to prevent dust and organic compounds including body oils from contaminating the strip surface.

Aluminium Wires

Atmospheric conditions affect weld quality. Moisture (H₂O) is a prime source of hydrogen. At arc temperatures, water breaks down releasing hydrogen atoms that cause porosity in weldments. Aluminium, which is allowed to repeatedly come into contact with water, will eventually form a hydrated oxide (AlOH) coating.

Moisture from condensation present on either the electrode or the base metal can cause two problems during welding:

- Porosity caused by hydrogen generated from the breakdown of water or from the breakdown of hydrated oxide (AlOH) present on the metal surfaces
- Entrapment of the actual oxide (AlOH) present on the metal surfaces, in the weldment

In an aluminium welding shop, the uniformity of air and metal temperatures is important, especially when the relative humidity is high. Electrode and base metal should be allowed to stabilise to the weld area temperature. The electrode should not be opened in the weld area for 24 hours after entry from a cooler storage area.

The base metal should be cleaned and brushed with a clean stainless steel brush prior to welding. ESAB recommends mild alkaline solutions and commercial degreasers that do not evolve into toxic fumes during welding. All surfaces must be thoroughly dried after cleaning.



Cored wires should be stored in their unopened and undamaged original packaging. Failure to do this may seriously reduce the durability of the cored wire.

Storage times should be kept to a minimum and stock rotation should be used.

Non and low alloyed cored wires are not susceptible to rapid moisture absorption since the core ingredients are protected from the atmosphere by the sheath. Strict QA procedures ensure all of ESAB's cored wires contain low levels of moisture in the as-manufactured condition.

To maintain low moisture levels, cored wires should be stored under correct conditions. 15-36 °C and humidity of <60% RH. Poor storage conditions can be detrimental to their performance and durability. Inadequate storage conditions can lead to surface rusting or contamination of the wire to the extent that feedability and diffusible hydrogen levels are adversely affected.

Stainless steel cored wires are more sensitive to moisture pick up. Therefore the spools are vacuum packed in metalised film pouches. The storage recommendations are the same as for unalloyed and low-alloyed cored wires.

For stainless steel cored wires, extra attention is required in order to ensure that they are returned to the correct storage conditions at the end of the working period.

Wires should not be left on welding machines or out of storage for prolonged periods, especially overnight, since condensation from moisture in the air may lead to rapid surface deterioration. Always replace wires in their original packaging and return them to controlled storage areas.

If a wire has been left on the equipment for a long period of time, it is good practice to run off at least one layer of wire to remove the worst of any surface oxidation or contamination that may have occurred.

All cored wires should avoid direct contact with water or moisture. This could take the form of rain or the condensation of moisture on a cold wire. To avoid condensation, the relative humidity and temperature must be monitored and the temperature should not fall below the dew point (listed in table on page 3).

Other hydrogen-containing substances like oil, grease and corrosion or substances that could absorb moisture must also be avoided on the wire surface.

Deteriorated Product

Cored wires that are rusty, have suffered from serious water and moisture contamination, or have been exposed to the atmosphere over long periods of time cannot be restored in their original condition and should be discarded.

ESAB ceramic weld metal supports and backing have no adverse influence on weld metal composition and mechanical properties. They are dry and insensitive to moisture absorption, leaving the cored wire's low-hydrogen performance unaffected.

ESAB agglomerated fluxes have a guaranteed as-manufactured moisture content from production. This moisture content is controlled by internal ESAB specifications. Before transport, each pallet is shrinked or wrapped in plastic foil. This precautionary action is done in order to maintain the as-manufactured moisture content for as long as possible. Flux should never be exposed to wet conditions, such as rain or snow.

Storage

- Unopened standard flux bags (made of PE or paper with PE inlay) must be stored in maintained storage conditions as follows:
 - Temperature: 20 +/- 10°C (68 +/- 18°F). Relative humidity: As low as possible - not exceeding 60%
- Fluxes delivered in BlockPac™, aluminium lined 25 kg bags, or BigBag, as well as in 25 kg steel buckets can be stored under severe climatic conditions because the packaging protects the flux from moisture pick-up, as long as it is unopened and undamaged
- Fluxes in BlockPac have unlimited durability as long as the foil is not damaged (label information might be outdated due to possible classification amendments or filler material standard updates)
- The content of unprotected flux hoppers must, after an 8 hour shift, be placed in a drying cabinet or heated flux hopper at a temperature of 150 +/- 25°C
- Remaining flux from opened bags must be placed at a temperature of 150 +/- 25°C

Flux Usage

- When handled and stored as recommended, ESAB fluxes can normally be used straight away
- In severe applications, stipulated by the applicable material specification or if the flux has somehow picked up moisture, re-drying of the flux is recommended
- Re-drying shall be performed as follows: 300 +/- 25°C for about 2-4 hours
- Re-drying must be done either in equipment that turns the flux so that the moisture can evaporate easily or in an oven on shallow plates with a flux height not exceeding 5 cm
- It is recommended to empty the flux feeding system on the C&B when welding activities will be stopped for more than 8 hours
- Re-dried flux, not immediately used, must be kept at 150 +/- 25°C before use

Recycling

- Moisture and oil must be removed from the compressed air used in the recycling system
- Addition of new flux must be done with the proportion of at least one part new flux to three parts recycled flux
- Foreign material, such as millscale and slag, must be removed by a suitable system, such as sieving

Disposal

- Discard any product, residue, disposable container or liner in an environmentally acceptable manner, in full compliance with federal and local regulations
- Please address your local disposal company for prescribed disposal
- Information on product and residues are given in the Safety Data Sheets available at www.esab.com

1. MMA electrodes for mild and low-alloyed steels

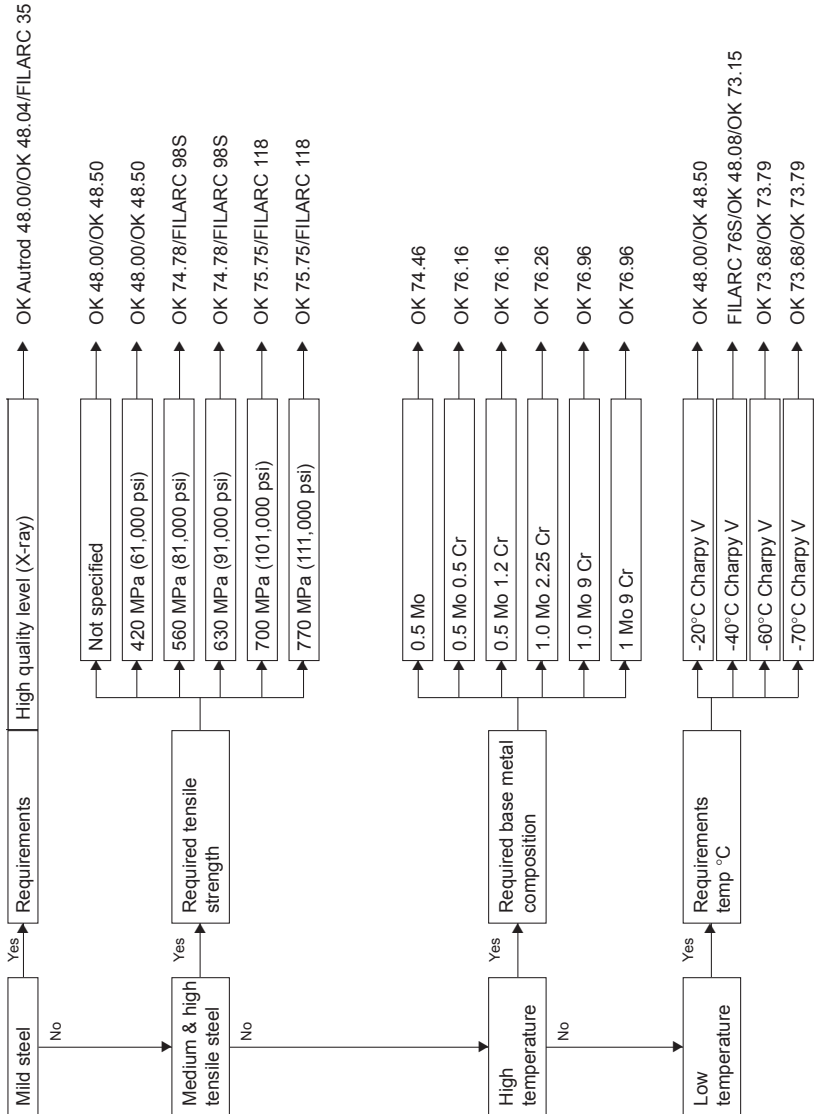

2. Solid wires

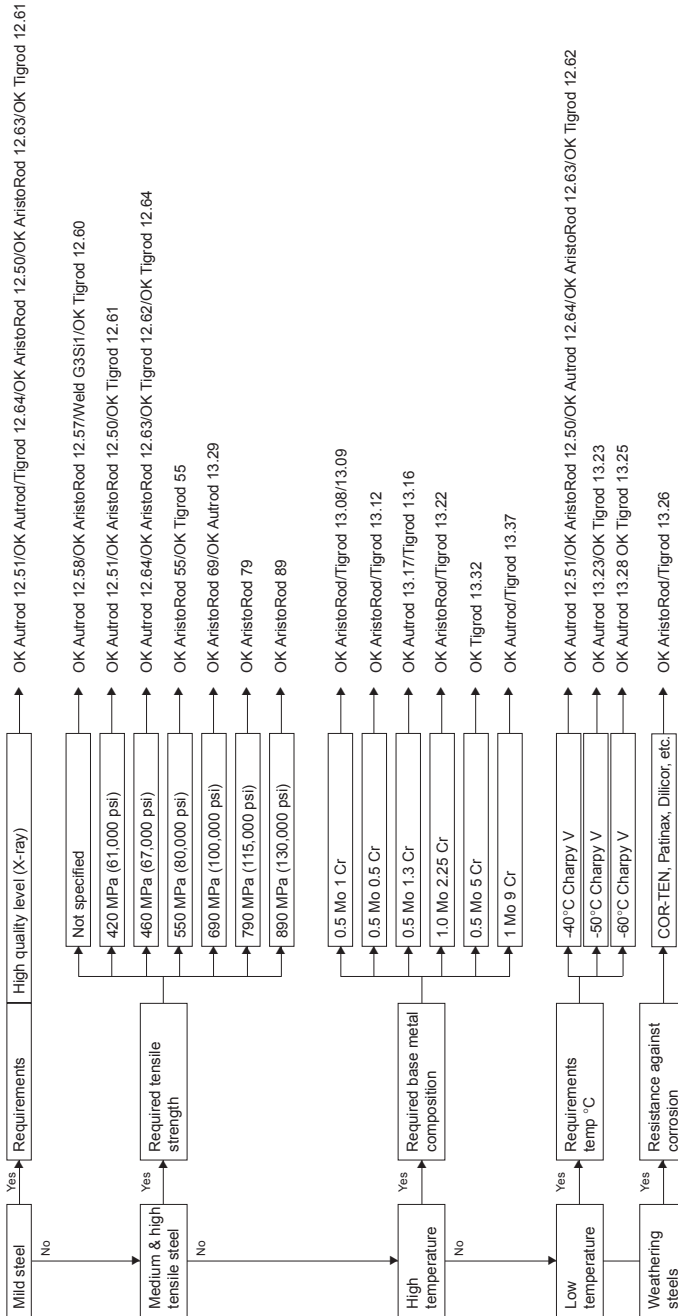

3. Submerged arc fluxes and wires

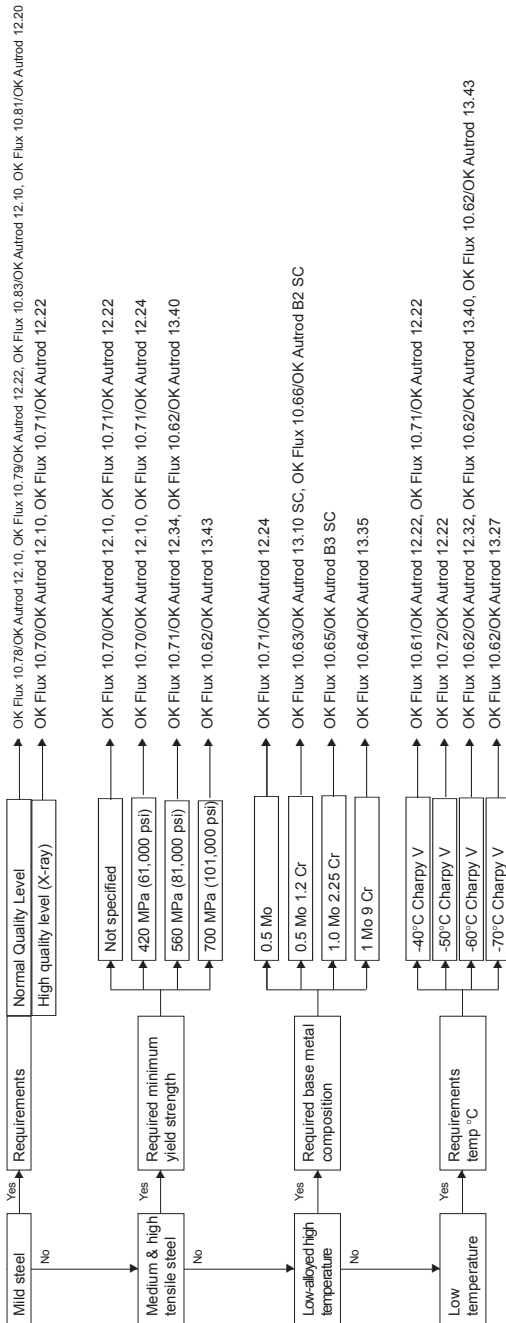

4. Cored wires

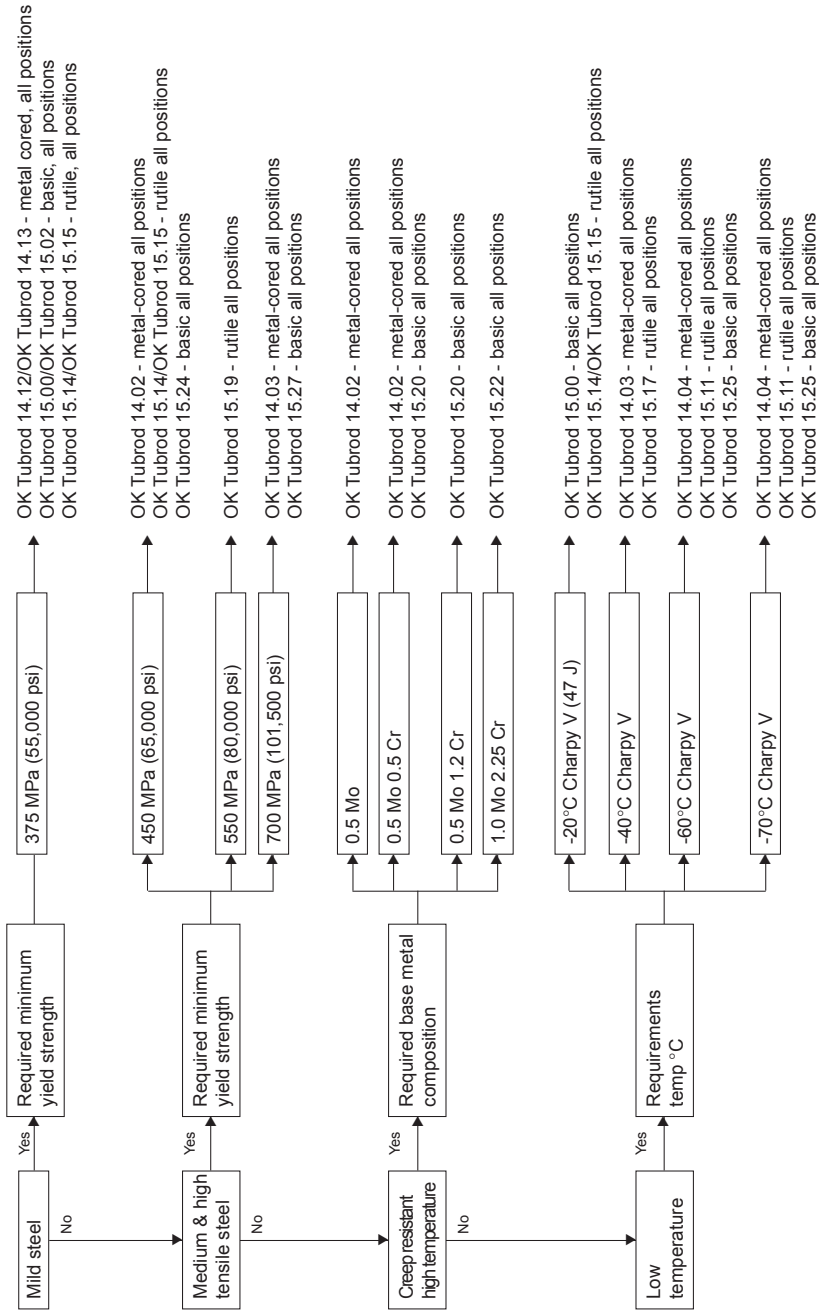

4. Submerged arc cored wires and fluxes

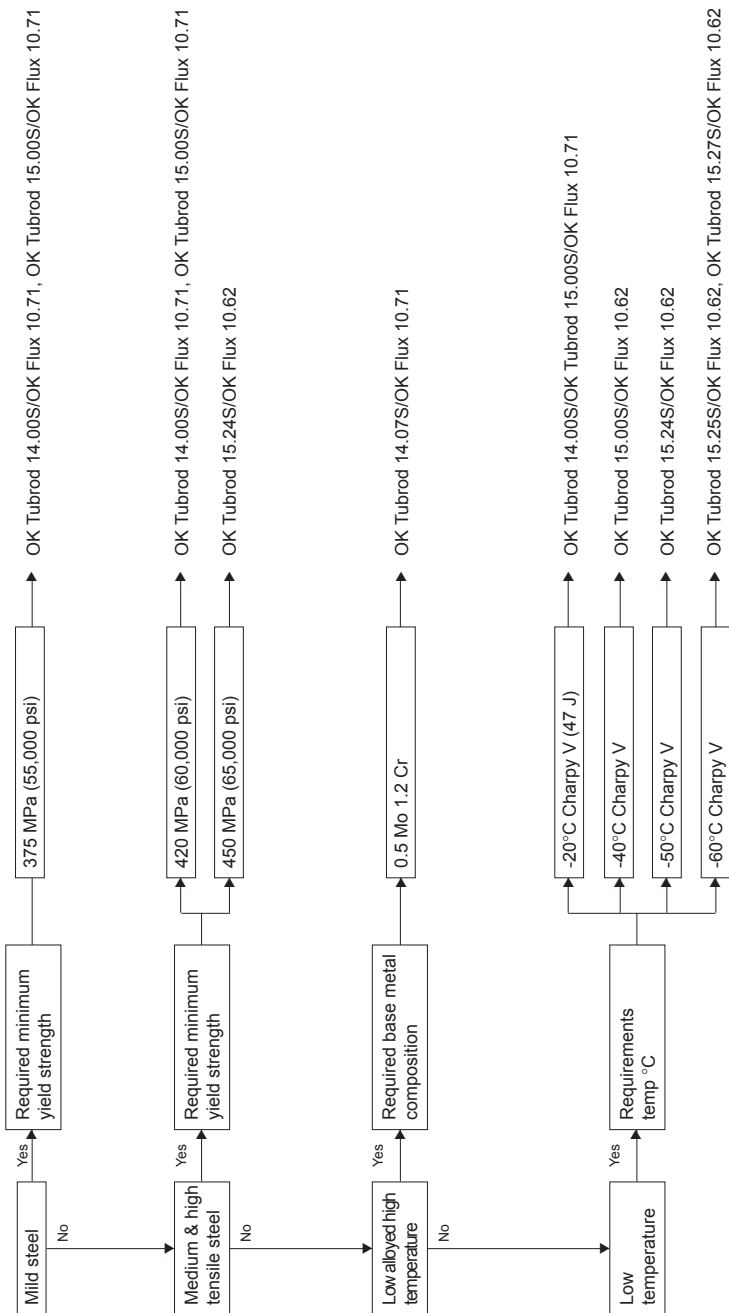

6. Wires for stainless steels - selection by wire classification

EN 10088-1 Designation	Werkst. Nr.	USA AISI	C	Cr	Ni	Mo	Other elements	MIG OK Autrod/ Exaton	TIG OK Tigrod/ Exaton
Austenitic									
X5CrNi18-10	1.4301	304	< 0.07	18	10	-	-	308LSi / 19.9.LSi	308L, 308LSi / 19.9.LSi
X5CrNi18-10	1.4301	304	< 0.03	18	10	-	-	19.9.L	19.9.L
X8CrNiS18-9	1.4305	303	< 0.12	18	9	-	S 0.2	308LSi, 309LSi / 24.13.LSi	308L, 308LSi, 309L
X2CrNi19-11	1.4306	304L	< 0.03	18	10	-	-	308LSi / 19.9.LSi	308L, 308LSi / 19.9.LSi
X2CrNi19-11 / C-Mn	1.4306	304L	< 0.03	18	10	-	-	24.13.LHF	24.13.LHF
X10CrNi18-8	1.4310	302	< 0.12	18	8	-	-	308LSi / 19.9.LSi	308L, 308LSi / 19.9.LSi
X2CrNiN18-10	1.4311	304LN	< 0.03	18	10	-	N 0.15	308LSi / 19.9.LSi	308L, 308LSi / 19.9.LSi
-	1.4335	S31002	< 0.015	24	20	-	-	25.20.L	25.20.L
X12CrMnNiN	1.4372	202	< 0.15	18	5	-	Mn 8	16.95 / AXT	16.95 / AXT
X2CrNiMo17-12-2 / C-Mn	1.4404	316L	< 0.03	17	12	2	-	309MoL	309MoL
X2CrNiMo17-12-2	1.4404	316L	< 0.03	17	12	2	-	19.12.3.LCRYO, 19.12.3.LSiMo	19.12.3.LCRYO, 19.12.3.LSiMo
X2CrNiMoN17-13-3	1.4429	316LN	< 0.03	18	12	2.5	N 0.5	(316L, 316LSi)	(316L, 316LSi)
X2CrNiMo18-14-3	1.4435	316L	< 0.03	18	13	2.5	-	316L, 316LSi, 316LMn	316L, 316LSi
X3CrNiMo17-13-3	1.4436	316	< 0.05	17	12	2.5	-	316LSi	316L, 316LSi
X2CrNiMo18-15-4	1.4438	S31703	< 0.03	18	16	3.5	-	317L	317L
X1CrNiMoN25-22-2	1.4466	S31050	< 0.02	25	22	2	N 0.12, Mn 1.7	25.22.2.LMn	25.22.2.LMn
X1NiCrMoCuN25-20-5	1.4539	N08904	< 0.03	20	25	4.5	Cu 1.5	20.25.5.LCu	20.25.5.LCu
X6CrNiTi18-10	1.4541	321	< 0.08	18	11	-	Ti 0.7	347Si, (308LSi)	347, 347Si, (308LSi)
X1CrNiMoCuN20-18-7	1.4547	S31254	< 0.02	20	18	6.2	Cu 0.8, N 0.2	NiCrMo-3 / Ni60	NiCrMo-3 / Ni60
X6CrNiNb18-10	1.4550	347	< 0.08	18	11	-	Nb 0.7	347Si, (308LSi)	347, 347Si, (308LSi)
X6CrNiNb18-10 / C-Mn	1.4550	347	< 0.08	18	11	-	Nb 0.7	24.13.LNb	-
X2NiCrAlTi32-20	1.4558	-	< 0.03	21	33	-	Al 0.3, Ti 0.3	Ni72HP	Ni72HP
X1NiCrMoCu31-27-4	1.4563	N08028	< 0.02	27	31	3.5	Cu 1.5	27.31.4.LCu	27.31.4.LCu
X6CrNiMoTi17-13-2	1.4571	316Ti	< 0.08	18	12	2.5	Ti 0.7	318Si, (316LSi)	318Si, (316LSi)
-	1.4652	S32654	< 0.02	24	22	7.3	Cu 0.5, N 0.5	Ni59	Ni59
-	1.4835	S30815	< 0.08	21	11	-	Si 1.6, N 0.17, Ce 0.05	22.12.HT	22.12.HT
X8CrNi25-21	1.4845	S31008	< 0.06	24	21	-	-	310	310
NiCr21Mo14W	2.4602	N06022	< 0.015	21	56	13	W 3, Co 2.5, Fe 4	Ni54	Ni54

6. Wires for stainless steels - selection by wire classification, continued

EN 10088-1 Designation	Werkst. Nr.	USA AISI	C	Cr	Ni	Mo	Other elements	MIG OK Autrod/ Exaton	TIG OK Tigrod/ Exaton
NiCr23Mo16Al	2.4605	N06059	< 0.01	23	59	16	Al 0.4, Co 0.3, Fe < 1.5	Ni59	Ni59
-	2.4606	N06686	< 0.01	21	56	16	W 3.7, Ti 0.2, Fe < 2	Ni55	Ni55
NiCr29Fe	2.4642	N06690	< 0.05	29	61	-	Fe 9, Cu 0.5	Ni68HP	Ni68HP
NiCr23Co12Mo	2.4663	N06017	< 0.15	22	44	9	Al 1.2, Ti 0.6, Cu 0.5, Co 13, Fe < 3	Ni53	Ni53
NiCr15Fe	2.4816	N06600	< 0.15	15	73	-	Al 0.3, Ti 0.3, Cu 0.5, Fe 8	Ni72HP	Ni72HP
NiMo16Cr15W	2.4819	N10276	< 0.01	16	57	16	Co 2.5, Fe 5	Ni56	Ni56
NiCr21Mo	2.4858	N08825	< 0.003	21	42	3	Ti 0.7, Cu 2, Al 0.1, Fe 30	27.31.4.LCu, Ni41Cu	27.31.4.LCu, Ni41Cu
NiCr22Mo9Nb	2.4866	N06625	< 0.03	22	60	9	Nb 3.5, Al 0.4, Ti 0.4, Fe 5	Ni60	Ni60
-	-	S32615	< 0.025	17	19	0.4	Cu 2.0	SX	SX
-	-	304N	< 0.08	18	9	-	N 0.15	308LSi / 19.9.LSi	308L, 308LSi / 19.9.LSi
Austenitic-ferritic (Duplex)									
-	1.4162	S32101	0.03	21.5	1.5	-	Mn 5	22.8.3.L, 22.8.3.LSi	22.8.3.L, 22.8.3.LSi
X2CrNiN23-4	1.4362	S32304	< 0.03	23	4	-	N 0.10	22.8.3.L, 22.8.3.LSi	22.8.3.L, 22.8.3.LSi
X2rNiMoN25-7-4	1.4410	S32750	< 0.03	25	7	4	N 0.25	25.10.4.L, 27.7.5.L	25.10.4.L, 27.7.5.L
X2CrNiMoN22-5-3	1.4462	S31803	< 0.03	22	5	3	N 0.10	22.8.3.L, 22.8.3.LSi	22.8.3.L, 22.8.3.LSi
-	1.4477	S32906	< 0.03	29	7	2	N 0.35, Cu 0.8	29.8.2.L	29.8.2.L
X2CrNiMoCuWN25-7-4	1.4501	S32760	< 0.03	25	6	3	N 0.25, W 0.7	25.10.4.L, 27.7.5.L	25.10.4.L, 27.7.5.L
-	1.4658	S32707	< 0.03	27	6	5	N 0.4, Co 1.0	27.7.5.L	27.7.5.L
Ferritic-martensitic									
X6Cr13	1.4000	403	< 0.08	13	-	-	-	308LSi	308L, 308LSi
X2CrNi12	1.4003	S41050	< 0.03	12	0.7	-	-	308LSi	308L, 308LSi
X12Cr13	1.4006	410	0.1	13	-	-	-	309LSi	309L, 309LSi
Ferritic									
X6Cr17	1.4016	430	< 0.08	16.5	-	-	-	308LSi, 439Ti, 430LNb, 430LNbTi	308LSi, 430LNbTi
X6CrTiNb18	1.4509	441	< 0.03	18	-	-	Ti, Nb	308LSi, 439Ti, 430LNb, 430LNbTi	-
X6CrTi17	1.4510	439	< 0.8	17	-	-	Ti	439Ti	-
X2CrMoTi18-2	1.4521	S44400	< 0.03	18	-	2	-	316LSi	316L, 316LSi
X15CrNiSi25-4	1.4821	-	< 0.2	25	4	-	N < 0.11	2504	2504

7. The most common fluxes and wires for SAW stainless steel

EN 10088-1 Designation	Werkst. Nr.	USA AISI	Recommended SAW consumables OK Flux + OK Autrod/Exaton
X6Cr13	1.4000	403	10.93+308L or 308H/10.92+308L
X12Cr13	1.4006	410	10.93+308L or 308H/10.92+308L
X6Cr17	1.4016	430	10.93+308L or 308H/10.92+308L
X20Cr13	1.4021	420	10.93+308L or 308H/10.92+308L
X30Cr13	1.4028	-	10.93+308L or 308H/10.92+308L
X17CrNi16-2	1.4057	431	10.93+347 or 10.92+347
-	1.4162	S32101	15W+22.8.3.L/10.94+22.8.3.L
X5CrNi18-10	1.4301	304	10.93+308L /10.92+308L
X5CrNi18-10	1.4301	304	15W+19.9.L
X5CrNi18-10	(1.4301)	(304)	10.93+308L /10.92+308L
X2CrNi18-9	1.4306	304 L	10.93+308L or 308H/10.92+308L
X2CrNi19-11 / C-Mn	1.4306	304L	15W+24.13.LHF
X2CrNiN18-10	1.4311	304 LN	(10.93+308L) or (10.92+308L)
X5CrNiN19-9	1.4315	-	10.93+308H
X2CrNiN23-4	1.4362	S32304	15W+22.8.3.L/10.94+22.8.3.L
X5CrNiMo17-12-2	(1.4401)	(316)	10.93+316L or 10.92+316L
X2CrNiMo17-12-2	1.4404	316 L	10.93+316L or 10.92+316L
X2CrNiMo17-12-2 / C-Mn	1.4404	316L	10.93+309MoL
X2CrNiMo17-12-2	1.4404	316L	15W+19.12.3.LCRYO
X2CrNiMoSi18-5-3	1.4417	-	20.5.3.L SAW
X2CrNiMoN17-13-3	1.4429	316 LN	(10.93+316L) or (10.92+316L)
X2CrNiMo18-14-3	1.4435	316 L	10.93+316L or 10.92+316L
X3CrNiMo17-13-3	1.4436	(316)	10.93+316L or 10.92+316L
X2CrNiMo18-15-4	1.4438	317 L	10.93+317L or 10.92+317L
X2CrNiMoN22-5-3	1.4462	S31803	15W+22.8.3.L/10.94+22.8.3.L
X1CrNiMoN25-22-2	1.4466	S31050	15W+25.22.2.LMn
X1NiCrMoCuN25-20-5	1.4539	N08904	15W+20.25.5.LCu
X6CrNiTi18-10	1.4541	321	10.93+347 or 10.92+347
X1CrNiMoCuN20-18-7	1.4547	S31254	10.93+NiCrMo-3 / 15W+Ni60
X6CrNiNb18-10	1.4550	347	10.93+347 or 10.92+347
X6CrNiNb18-10 / C-Mn	1.4550	347	15W+24.13.LNb
X2NiCrAlTi32-20	1.4558		10.90 + Ni72HP
X1NiCrMoCu31-27-4	1.4563	N08028	15W+27.31.4.LCu
X6CrNiMoTi17-12-2	1.4571	316 Ti	(10.93+316L) or (10.92+316L)
-	1.4652	S32654	50SW+Ni59

1 not standard

7. The most common fluxes and wires for SAW stainless steel, continued

EN 10088-1 Designation	Werkst. Nr.	USA AISI	Recommended SAW consumables OK Flux + OK Autrod/Exaton
X18CrN28	1.4749(1)	446	10.92+310
-	1.4835	S30815	15W+22.12.HT
(EN 10095) X8CrNi25-21	1.4845(1)	310 S	10.92+310
NiCr23Mo16Al	2.4605	N06059	50SW+Ni59
NiCr15Fe	2.4816	N06600	50SW+Ni72HP
NiMo16Cr15W	2.4819	N10276	15W+Ni56
NiCr21Mo	2.4858	N08825	15W+27.31.4.LCu or Ni41Cu
NiCr22Mo9Nb	2.4866	N06625	15W+Ni60
X2CrNiMoN25-7-4	-	S32750	15W+25.10.4.L/10.94+25.10.4.L
X2CrNiMoCaWN25-7-4	-	S32760	15W+25.10.4.L/10.94+25.10.4.L
X10CrNi18-8	-	302	10.93+308L /10.92+308L

1 not standard

8. Comparison table for stainless steels and MMA electrodes, part 1

European standard EN 10088-1/EN 10095 Designation	Werkst. Nr.	SS steel No	England BS 970; 1=Part 1 BS 1449; 2=Part 2
X 6 Cr 13	1.4000	2301	403 S 17
X 12 Cr 13	1.4006	2302	410 S 21
X 20 Cr 13	1.4021	2303	420 S 37
X 30 Cr 13	1.4028	2304	420 S 45
X 6 Cr 17	1.4016	2320	430 S 17
X 17 Cr Ni 16-2	1.4057	2321	431 S 29
X 18 Cr N 28	1.4749'	2322	-
X 4 Cr Ni Mo N 27-5-2	1.4460'	2324	-
X 10 Cr Ni 18-8	1.4310	2331	302 S 31
X 5 Cr Ni 18-10	1.4301	2332	304 S 31
X 5 Cr Ni 18-10	1.4301	2333	(304 S 15)
X 6 Cr Ni Ti 18-10	1.4541	2337	321 S 31
X 6 Cr Ni Nb 18-10	1.4550	2338	347 S 31
X 3 Cr Ni Mo 17-13-3	1.4436	2343	(316 S 33)
X 8 Cr Ni S 18-9	1.4305	2346	303 S 31
X 5 Cr Ni Mo 17-12-2	(1.4401)	2347	(316 S 31)
X 2 Cr Ni Mo 17-12-2	1.4404	2348	316 S 11
X 6 Cr Ni Mo Ti 17-12-2	1.4571	2350	320 S 31
X 2 Cr Ni 18-9	1.4307	2352	304 S 11
X 2 Cr Ni Mo 18-14-3	1.4435	2353	316 S 3
X 8 Cr Ni 25-21	1.4845	2361	(310 S 24)
X 2 Cr Ni Mo 18-15-4	1.4438	2367	-
X 2 Cr Ni N 18-10	1.4311	2371	-
X 2 Cr Ni Mo N 17-13-3	1.4429	2375	-
X 12 Cr S 13	1.4005	2380	416 S 21
X 14 Cr Mo S 17	1.4104	2383	-
X 2 Cr Ni N 23-4	1.4362	2327	-
X 2 Cr Ni Mo N 22-5-3	1.4462	2377	-
X 2 Cr Ni Mo N 25-7-4	1.4410	2328	-
X 2 Cr Ni Mo Cu WN 25-7-4	1.4501	-	-

8. Comparison table for stainless steels and MMA electrodes, part 2

France AFNOR NFA 35-572 to NFA 35-578	USA AISI	Japan JIS G4303-4318 SUS	Italy UNI 6900-71	MMA electrode OK/Exaton
Z 6 C 13	403	403	X 6 Cr 13	61.30, 61.35, 68.15
Z 12 C 13	410	410	X 10 Cr 13	61.30, 61.35, 68.15
Z 20 C 13	420	420 J1	X 20 Cr 13	61.30, 61.35, 68.15
Z 30 C 13	-	420 J2	X 38 Cr 13	61.30, 61.35, 68.15
Z 8 C 17	430	430	X 8 Cr 17	61.30, 61.35, 61.80
Z 15 CN 16.02	431	431	X 16 Cr Nr 16	61.30, 61.35, 61.80
Z 10 C 24	446	-	X 16 Cr 26	67.15
-	329	329 J1	-	67.50, 22.9.3.LR
Z 10 CN 18.09	302	302	-	61.30, 61.35
Z 6 CN 18.09	304	304	X 5 Cr Ni 18 10	61.30, 61.35
(Z 6 CN 18.09)	(304)	(304)	(X 5 Cr Ni 18 10)	61.30, 61.35
Z 6 CNT 18.10	321	321	X 6 Cr Ni Ti-18 11	(63.34), 61.80, 61.85
Z 6 CNNb 18.10	347	347	X 8 Cr Ni Nb 1811	(63.34), 61.80, 61.85
(Z 6 CND 17.12)	(316)	(316)	(X 5 Cr Ni Mo 17 13)	63.30, 63.34, 63.35, 63.41
Z 10 CNF 18.09	303	303	X 10 Cr Ni 18 09	68.81
(Z 6 CND 17.11)	(316)	(316)	X 5 Cr Ni Mo 17 12	63.30, 63.34, 63.35, 63.41
Z 2 CND 17.12	316 L	316 L	X 2 Cr Ni Mo 17 2	63.30, 63.34, 63.35, 63.41
Z 6 CNDT 17.12	316 Ti	-	X 6 Cr Ni Mo Ti 17 12	63.80, 63.85
Z 2 CN 18.10	304 L	304 L	X 2 Cr Ni 18 11	61.30, 61.35
Z 2 CND 17.13	316 L	316 L	X 2 Cr Ni Mo 17 13	63.30, 63.34, 63.35, 63.41
(Z 12 CN 25-20)	310 S	310 S	X 6 Cr Ni 2520	67.15
Z 2 CND 19.15	317 L	317 L	X 2 Cr Ni Mo 18 16	64.30
Z 2 CN 18.10 Az	304 LN	304 LN	X 2 Cr Ni N 18 11	61.30, 61.35
Z 2CND 18.10 Az	316 LN	316 LN	X 2 Cr Ni Mo N 17 13	63.30, 63.35, 63.41, 69.25
Z 12 CF 13.4 M	416	416	X 12 Cr S 13	61.30, 61.35, 68.15
Z 10 CF 17	430 F	430 F	X 10 Cr S 17	61.30, 61.35
-	S32304	-	-	67.50, 67.55, 22.9.3.LR/LB
-	S31803	-	-	67.50, 67.55, 22.9.3.LR/LB
-	S32750	-	-	68.53, 68.55, 25.10.4.LR/LB
-	S32760	-	-	68.53, 68.55, 25.10.4.LR/LB

9. MIG and TIG wires for aluminium

EN 573 Alloy designation Numerical ¹⁾	Chemical symbols	The Aluminum Association	ESAB filler metal OK Autrod/Tigrod
EN AW-1050A	EN AW-Al 99,5	AA 1050A	1070,1100, 1450
EN AW-1070A	EN AW-Al 99,7	AA 1070A	1070,1100, 1450
EN AW-1100	EN AW-Al 99,0Cu	AA 1100	10,701,100
EN AW-1200	EN AW-Al 99,0	AA 1200	10,701,100
EN AW-3003	EN AW-Al Mn1Cu	AA 3003	4043, 4047
EN AW-3103	EN AW-Al Mn1	AA 3103	4043, 5356
EN AW-3004	EN AW-Al Mn1Mg1	AA 3004	4043, 5356
EN AW-4045	EN AW-Al Si10	AA 4045	40,434,047
EN AW-5005	EN AW-Al Mg1(B)	AA 5005	5356
EN AW-5019	EN AW-Al Mg5	AA 5019	5356
EN AW-5050	EN AW-Al Mg1,5(C)	AA 5050	5356
EN AW-5052	EN AW-Al Mg2,5	AA 5052	5356
EN AW-5083	EN AW-Al Mg4,5Mn0,7	AA 5083	5183
EN AW-5086	EN AW-Al Mg4	AA 5086	5356
EN AW-5454	EN AW-Al Mg3Mn	AA 5454	5554
EN AW-6013	EN AW-Al Mg1Si0,8CuMn	AA 6013	4043, 5356
EN AW-6060	EN AW-Al MgSi	AA 6060	4043, 5356
EN AW-6061	EN AW-Al Mg1SiCu	AA 6061	5356
EN AW-6063	EN AW-Al Mg0,7Si	AA 6063	5356
EN AW-6082	EN AW-Al Si1MgMn	AA 6082	4043, 5356
EN AW-7005	EN AW-Al Zn4,5Mg1,5Mn	AA 7005	5356
EN AW-7021	EN AW-Al Zn5,5Mg1,5	AA 7021	5356
EN AW-7029	EN AW-Al Zn4,5Mg1,5Cu	AA 7029	5356
EN AW-7039	EN AW-Al Zn4Mg3	AA 7039	5356
EN AW-7050	EN AW-Al Zn6CuMgZr	AA 7050	5356

Hand Welding Electrodes

Official Approval

In addition to the official approval given in this catalogue, many OK electrodes are approved by foreign authorities, railway boards, private companies and so on. Information about the different types of approval is available on request.

Tensile Properties

Unless otherwise stated, tensile properties refer to all weld metal test pieces prepared according to the rules of the classification societies using 4 and 6 mm diameter electrodes.

Welding Current

Maximum and minimum values are given. The most suitable welding current depends largely on the size of the workpiece, the welding position, and the type of joint.

Small workpieces require a lower current, larger workpieces a higher current, depending on the dissipation of heat from the joint.

Cold Cracking

Cold cracking will only occur if the following three factors are present at the same time:

1. Hard phases in the weld, preferably martensite
2. Sufficient stress
3. Hydrogen dissolved in the weld metal

Hard phases form when the weld is cooled rapidly from melting temperature to room temperature. Alloying elements, mostly carbon, are forced to dissolve in the weld metal and make it brittle. The following formula describes this process in the case of standard carbon-manganese steel.

$$E_C = \%C + \frac{\%Mn}{6} + \frac{\%(Cr+Mo+V)}{5} + \frac{\%(Ni+Cu)}{15}$$

Steels with $E_C = 0.35$ and below are usually weldable without any problems at normal steel sizes. For the more highly alloyed steels and steels with thicker dimensions, an elevated working temperature is necessary in order to reduce the cooling rate.

The elevated temperature also allows the hydrogen to diffuse.

To determine elevated working temperatures, please consult BS EN 1011-2 (2011). If the E_C dimension of the plates and heat input are known, these standards will state whether heating is necessary and the level at which it should take place.

Tension cannot be avoided when welding, as steel expands when heated, although correct planning and heat treatment can reduce tension considerably.

Hydrogen forms from water in the surroundings and from the electrode coating. The water is divided into oxygen and hydrogen in the arc and the hydrogen in particular has a strong tendency to dissolve in the weld metal and initiate cold cracking.

If the E_C value, dimension of the plates and the heat input are known, these standards state what working temperature is required for sound welds.

Whenever there is a risk for cold cracking, use dry basic electrodes and make sure that the weld surfaces are dry and properly cleaned prior to welding.

Electrode Imprint

Each electrode contains an electrode imprint near the grip end to enable proper identification of electrodes and stub ends after they have been welded, for example OK 48.00/7018H4R.

Choice of Suitable Electrode

The OK electrodes in this catalogue are placed into groups according to the type of alloy deposited. Within each group of electrodes for welding mild, low alloy and stainless steels, there are several cases in which many different electrodes are designed for welding the same type of steel. So, for each steel grade, there are often a large number of electrode types to choose from, all of which produce similar weld metal compositions but have different coatings, welding properties, welding speeds and weld metal quality. This large choice makes it possible to choose the electrode which produces the right weld metal quality at the lowest cost.

When selecting an electrode, the first rule is to select one which produces a weld metal quality equal to or better than that of the base material and, when necessary, is approved for the material in question. Welding position and type of joint are other factors which have to be considered because certain electrodes may have been optimized for specific welding positions and joint configurations.

Influence of Coating Type on Welding Properties, Welding Speed and Weld Metal Quality

Rutile electrodes giving about 100% weld metal recovery are easy to strike and use and are particularly suitable for short welds in mild steel, for fillet welds, welding sheet steels and for bridging large joint gaps. The welds have a fine finish and spatter losses are negligible. The welding speed is moderate.

Unalloyed Electrodes

Unalloyed rutile electrodes are not normally recommended for welding steel with a nominal tensile strength exceeding 440 MPa (45 kp/mm²). Rutile electrodes are relatively insensitive to moisture.

High-Efficiency Rutile Electrodes

High-efficiency rutile electrodes generally produce a higher welding speed, which increases as the weld metal recovery increases, up to a maximum of about 140 g/min for 6 mm diameter OK Femax 33.80.

They are all easy to use, produce excellent slag detachability, fine bead appearance and are particularly suitable for welding horizontal/vertical fillets. The weld metal has tensile properties which are as high as, or somewhat higher than, those of the weld metal from unalloyed basic electrodes but have lower elongation and impact strength.

The evenness of the weld and the smooth transition of the base material make joints produced with rutile electrodes at least as good in terms of fatigue strength as unmachined joints produced using basic electrodes. Unalloyed rutile electrodes, irrespective of their efficiency, can be recommended for welding mild steel with a nominal tensile strength of 440 MPa (45 kp/mm²). When it comes to the tensile strength of the deposit, rutile electrodes can also be used for welding steels with a nominal tensile strength of more than 440 MPa (45 kp/mm²), but as a general rule, only electrodes producing a weld metal with a low hydrogen content, e.g. basic, rutile-basic or zircon-basic electrodes, should be used to weld these steels.

Acid Electrodes

Acid electrodes without iron powder in the covering are easier to strike than basic electrodes, but more difficult to strike and re-strike than rutile electrodes. The welding speed is moderate. The weld beads are smooth and shiny. The slag is inflated and easy to remove. The weld metal has a lower yield stress and tensile strength compared with that produced by rutile electrodes, but it has higher elongation and impact strength.

This type of electrode, which completely dominated the market a few decades ago, has gradually been replaced by rutile electrodes for welding in the flat position and basic electrodes for positional welding. Unalloyed acid electrodes are suitable for welding steels with a nominal tensile strength of up to 440 MPa (45 kp/mm²).

High-Efficiency Acid Electrodes

High-efficiency acid electrodes have a considerably higher welding speed than normal electrodes, up to a maximum of about 120 g/min for 6 mm diameter OK Femax 39.50. The beads are smooth and shiny. The slag is inflated and easy to remove. High-efficiency acid electrodes are particularly suitable for making butt joints and fillet welds in the flat position. OK Femax 39.50 in long lengths is suitable for gravity welding with short-neck equipment.

The weld metal has the same strength as that produced by normal acid electrodes and the range of applications is therefore similar, i.e. they are suitable for welding mild steels with a nominal tensile strength of no more than 440 MPa (45 kg/mm²).

Choose the Correct OK Electrodes, Wires and Fluxes for Hardfacing and Maintenance

Recommendations for the right choice of electrodes for joining dissimilar materials can be found in Figs 1 and 2 on the next page.

The conditions to be considered when choosing the correct electrode, wire and flux for hardfacing and maintenance are summarised in the following outline.

A classification of weld metal resistance to different kinds of working condition can be found in Table 1.

The working conditions for an object that is going to be repaired are often known. The table provides information about suitable electrodes and the different kinds of attack which must be taken into account.

The recommended OK electrodes, wires and fluxes for some of the most common objects for hardfacing and maintenance by welding can be found in Table 2.

Short rules for choosing the correct type of weld metal alloy for hardfacing and cladding with regard to:

1. Type of wear
2. Working conditions
3. Machinability requirements

Useful information when choosing the correct type of alloy

1. The composition of the material to be welded when deciding:
 - Which types of welding alloy are usable and suitable
 - If preheating is favourable
 - If welding a buffer layer is necessary
2. Conditions for welding:
 - Is preheating possible or not? If it is not possible, hardenable welding alloys can only be used to a very limited extent.

For steel and cast iron weldments, austenitic or non-ferrous alloys are preferable:

- OK 67.45, OK 67.75 – austenitic
 - OK 68.81 and OK 68.82 – austenitic-ferritic
 - OK NiFe-Cl, OK NiFe-Cl-A,
 - OK NiCrMo-5 – non-ferrous
 - The welding position
 - Can submerged arc welding or gas metal arc welding be applied?
 - For which of the applicable welding processes is suitable filler material available?
3. Working conditions for the repaired workpiece:
 - Type of wear: abrasive, erosive or cavitation. To resist abrasive wear by sharp-edged blast stone and ore, a hard surface or a work-hardening surface is required or desirable.
Recommended:
OK Weartrode 60T, OK Weartrode 65T
OK Weartrode 55 HD, OK Weartrode 60
OK 13Mn, OK 14MnNi
 - To resist erosive wear, a hard surface and a fine-grained microstructure in the weld metal is required.
Recommended:
OK Weartrode 65T, OK Weartrode 60T
OK Tooltrode 60, OK Weartrode 55HD
OK Weartrode 60
 4. Environment:
 - Corrosive or non-corrosive?
 - The temperature, high or low?
 - To resist wear in a corrosive environment, the weld metal must be resistant to both corrosion and wear. So, depending on the severity of the corrosion attacks, an alloy with some degree of corrosion resistance is required.

Choose the right OK Electrodes for joining dissimilar materials

Fig. 1

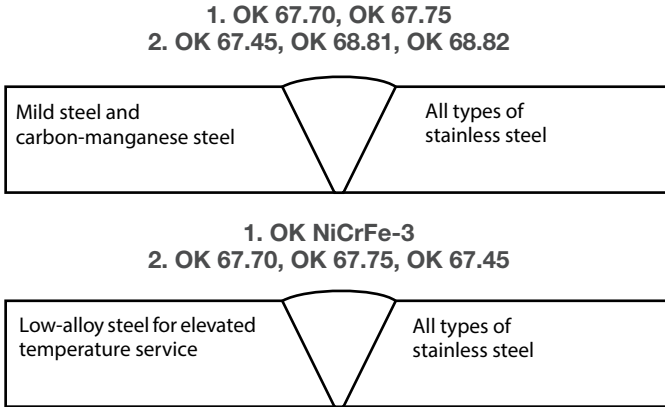

Never use unalloyed electrodes for these joints:

Fig. 2

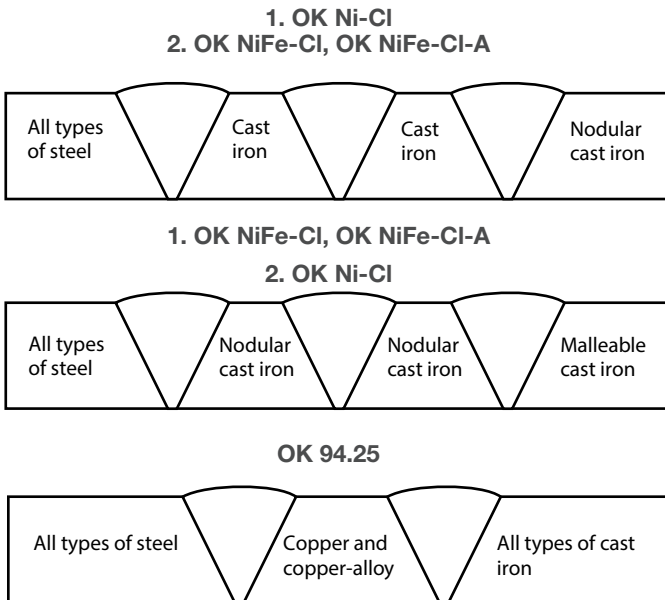

- 1. First choice
- 2. Second choice

Table 1. Hardfacing and cladding

Choose the right OK electrode for different working conditions.

Environment	Resistance-Suitability 5. Superior 3. Good 1. Limited Usability
Corrosive Environment Requirements: Corrosion Resistance	5. OK NiCrFe-3, OK NiCrMo-5, OK NiCu-7 OK 94.25, Stoodite 1 4. OK 68.81, OK 68.82, OK 67.45 3. OK Weartrode 65 T, OK Weartrode 60T 2. OK Weartrode 55 HD, OK Weartrode 50 1. OK Weartrode 30, OK Weartrode 60, OK Tooltrode 50, OK Tooltrode 60, OK 13Mn
High Temperature Oxidizing Requirements: Scaling Resistance	5. OK NiCrFe-3, OK NiCrMo-5 4. OK 68.81, OK 68.82, OK Weartrode 60 T, OK 67.45, OK Weartrode 60, OK Weartrode 65 T 3. OK Weartrode 55 HD, OK Weartrode 50, OK Weartrode 60 2. OK Weartrode 50, OK NiCu-7 1. OK Weartrode 30, OK 13Mn, OK 14MnNi
Annealing, Softening Requirements: Hardness at high temperature, annealing resistance	5. OK NiCrMo-5 4. OK Weartrode 60 T, OK Tooltrode 50, OK Tooltrode 60 3. OK Weartrode 50, OK Weartrode 55HD, OK Weartrode 60 2. OK Weartrode 30, OK 13Mn, OK 14MnNi, OK 68.81, OK 68.82 1. OK 67.45
Low Temperature Requirements: Cold Toughness	5. OK NiCrFe-3, OK NiCrMo-5, OK NiCu-7, OK 67.45, OK 94.25 4. OK 14MnNi, OK 13Mn 3. OK Weartrode 30, OK 68.81, OK 68.82 2. OK Weartrode 50 1. OK Weartrode 60, OK Weartrode 55 HD, OK Weartrode 60 T, OK Tooltrode 60
Type of Wear Impact, high surface pressure Requirements: Impact resistance and resistance to crushing	5. OK NiCrMo-5, OK 13Mn, OK 14MnNi, OK 68.81, OK 68.82 4. OK 67.45, OK Weartrode 30 2. OK Tooltrode 60 1. OK Weartrode 50, OK Weartrode 60, OK Weartrode 55 HD, OK Weartrode 60 T, OK 94.25, Stoodite 1
Wear by Blast Stone and Ore Requirements: High surface-hardness or cold-work hardening weld metal	5. OK Weartrode 60 T, OK Weartrode 62, OK Weartrode 65 T, Stoodite 1 4. OK 13Mn, OK 14MnNi, OK Weartrode 60, OK Tooltrode 60 3. OK Weartrode 50, OK Weartrode 55 HD, Stoodite 6 2. OK Tooltrode 50, OK 68.81, OK 68.82, OK 67.45 1. OK Weartrode 30
Wear by Fine Grained Materials Sand and Clay Requirements: High surface hardness	5. OK Weartrode 62, OK Weartrode 60 T, OK Weartrode 65 T, Stoodite 1 4. OK Weartrode 60, OK Tooltrode 60 3. OK Weartrode 55 HD, OK Weartrode 50, Stoodite 6 2. OK 68.81, OK 68.82 1. OK 67.45, OK Weartrode 30, OK 13Mn, OK 14MnNi
Cavitation	5. OK 63.35, OK 67.70, Stoodite 6 4. OK 67.45, OK 94.25 2. OK Weartrode 55 HD, Stoodite 1 1. OK Weartrode 30

Table 2. Application range electrodes, wires and fluxes for hardfacing and maintenance

Object	Required Weld Hardness	Consumables for MMA	Consumables for MAG, MIG, FCAW, SAW	Recommended Post Weld Treatment
Shafts NB! Stress relief is recommended for shafts subject to fatigue	< 250 HV 200-300 HV 30-35 HRC 35-40 HRC 44-49 HRC 50-56 HRC	OK 48.xx, OK 55.00 OK 74.78, OK 74.79 OK Weartrode 30/30 HD OK Weartrode 45 OK Weartrode 50/55	OK Flux 10.96/OK Autrod 12.10 OK Flux 10.71/OK Tubrodur 35 S M OK Flux 10.61/OK Tubrodur 13Cr S	Stress relief Stress relief Stress relief Stress relief
Caterpillar tracks Links	30-35 HRC 35-40 HRC	OK Weartrode 30/30 HD	OK Flux 10.96/OK Autrod 12.10 OK Flux 10.71/OK Tubrodur 35 S M	-
Plates and rollers	31-35 HRC 45-50 HRC	OK Weartrode 30/30 HD OK 14MnNi, work hardening	OK Tubrodur 15CrMn O/G OK Tubrodur 13Mn O/G	-
Brake shoes	30-35 HRC 45-50 HRC	OK Weartrode 30/30 HD OK 14MnNi, work hardening	-	-
Mixer arms, etc	50-56 HRC 55-63 HRC > 62 HRC > 62 HRC	OK Weartrode 55 OK Weartrode 55 HD OK Weartrode 60 T OK Weartrode 65 T OK Weartrode 62	OK Tubrodur 13Cr G OK Tubrodur 55 O A	-
Impellers for mills and crushers	50-58 HRC 58-63 HRC 63 HRC	OK Weartrode 55 HD OK Weartrode 60 OK Weartrode 60 T OK Weartrode 62	OK Tubrodur 58 OG M OK Tubrodur 55 O A	-
Excavator teeth, forged: Joining Hardfacing	55-58 HRC 58-63 HRC	OK 48.xx, OK 55.00 OK Femax 38.65 OK 48.xx + OK Weartrode 55/55 HD OK 48.xx + OK Weartrode 60 OK Weartrode 60 T OK Weartrode 65 T	OK AristoRod 12.50, OK Autrod 12.51 OK Tubrodur 30 O M + OK Tubrodur 58 O/G M OK Tubrodur 55 O A	-
Excavator teeth, 13% Mn steel Joining	-	OK 67.45	OK Tubrodur 200 O D	-
Hardfacing	≈ 50 HRC 55-58 HRC > 62 HRC	OK 48.xx OK 48.xx + OK Weartrode 55/55 HD OK Weartrode 62	OK Tubrodur 30 O M OK Tubrodur 58 O/G M	-
Excavator buckets, 13% Manganese steel: Joining Hardfacing	55-58 HRC 58-63 HRC	OK 67.45 OK 67.75 OK 48.xx OK Weartrode 55 HD OK Weartrode 60 OK Weartrode 65 T	OK Tubrodur 200 O D OK Tubrodur 58 O/G M OK Tubrodur 55 O A	-

Table 2. Application range electrodes, wires and fluxes for hardfacing and maintenance
Continued

Object	Required Weld Hardness	Consumables for MMA	Consumables for MAG, MIG, FCAW, SAW	Recommended Post Weld Treatment
Wheel beds for cranes, lorries and loading wagons	< 250 HV 200-300 HV 30-35 HRC 40-45 HRC	OK 48.xx OK 74.78 OK Weartrode 30, OK Weartrode 30 HD OK Weartrode 30	OK Flux 10.96/OK Autrod 12.10 OK Flux 10.71/OK Tubrodur 35 S M OK Tubrodur 13Mn O/G OK Tubrodur 15CrMn O/G	Stress relief Stress relief
Guillotine blades	50-56 HRC	OK Weartrode 55	OK Tubrodur 13Cr G	-
Cold die and cutting tools	60-65 HRC	OK Weartrode 60	-	-
Cog wheels and bars	< 250 HV 200-300 HV 30-35 HRC 44-49 HRC 51-56 HRC 55-58 HRC	OK 48.xx OK 74.78 OK Weartrode 30 OK Weartrode 30 DH OK Weartrode 45 OK Weartrode 50	OK AristoRod 12.50, OK Autrod 12.51 OK AristoRod 13.12 OK Flux 10.71/OK Tubrodur 35 S M OK Tubrodur 15.73 + OK Autrod 13.91 OK Flux 10.71/OK Tubrodur 58 S M	-
Feed gears	50-56 HRC 55-63 HRC 30-40 HRC	OK Weartrode 50 OK Weartrode 55 OK Weartrode 55 HD OK Weartrode 60 T OK Weartrode 65 T	OK Tubrodur 58 O/G M OK Tubrodur 55 O A OK Tubrodur 200 O D	Hammering
Dredger buckets 13% Mn steel	200-230 HV* 30-50 HRC* 50 HRC 55-58 HRC > 62 HRC	OK Weartrode 30 OK 67.45 OK 48.xx OK Weartrode 55/55 T OK Weartrode 60 T OK Weartrode 65 T OK Weartrode 62	OK Tubrodur 15CrMn O/G OK Tubrodur 200 O D OK Tubrodur 58 O/G M, OK Autrod 13.91 OK Tubrodur 55 O A	-
Links and pins 13% Mn steel	-	See buckets, Mn steel	-	-
Buckets, links and pins of carbon steel or low alloyed steel	< 250 HV 200-300 HV 200-300 HV 31-35 HRC 44-50 HRC	OK 48.xx OK 74.78 OK 67.45 OK Weartrode 30 OK Weartrode 30 HD OK Weartrode 45 OK 14MnNi	OK AristoRod 12.50, OK Autrod 12.51 OK AristoRod 13.12 OK Tubrodur 200 O D OK Tubrodur 30 O M OK Tubrodur 40 O M OK Tubrodur 15CrMn O/G	-
Chequer-net wearing plates	50-58 HRC 58-63 HRC > 62 HRC	OK Weartrode 55 HD OK Weartrode 60 OK Weartrode 60 T OK Weartrode 65 T OK Weartrode 62	OK Tubrodur 58 O/G M OK Tubrodur 55 O A	-

Table 2. Application range electrodes, wires and fluxes for hardfacing and maintenance
Continued

Object	Required Weld Hardness	Consumables for MMA	Consumables for MAG, MIG, FCAW, SAW	Recommended Post Weld Treatment
Unalloyed and low alloyed C steel	< 250 HV 250-300 HV 31-35 HRC 45-50 HRC** 50-58 HRC	OK 48.xx OK 74.78, OK 74.79 OK Weartrode 30 OK Weartrode 30 HD OK 14MnNi OK Weartrode 55	OK Flux 10.96/OK Autrod 12.10 OK Tubrodur 15CrMn O/G OK Flux 10.71/OK Tubrodur 58 S M OK Autrod 13.91	-
13% Mn steel	200-230 HV 400 HV**	OK 14MnNi OK 67.45	OK Tubrodur 200 O D OK Tubrodur 15CrMn O/G	-
Forging tools	31-35 HRC ≈ 40 HRC** ≈ 45 HRC 40-52 HRC	OK Weartrode 30 OK NiCrMo-5 OK Weartrode 45 Stoodite 1, Stoodite 6	OK Tubrodur 30 O M OK Tubrodur 13Cr G	Tempering 550°C

*Chromium-carbide ≈ 1500 HV

**Work-hardened

OK 48.xx = all electrodes of the OK 48-series

General Recommendations GMAW

GMAW – Gas Metal Arc Welding

The electrodes and joint faces should be clean. This is particularly important when welding aluminium and aluminium alloys. The shielding gases which are used must be of a purity suitable for welding. Moisture in the gas can produce porous welds.

Shielding Gas for Mild and Low-Alloy Steels

Carbon dioxide, CO₂, is the cheapest and most commonly used gas and, in most cases, it produces satisfactory welds in both mild and low-alloy steel.

Mixed gas, of which the most commonly used consists of 80% Ar + 20% CO₂, is more expensive than pure CO₂, but produces a softer arc, quieter welding, better bead appearance and less spatter. It is therefore often used, in spite of its higher price, for welding sheet steel 0.8-1.5 mm thick, which is more difficult to weld with pure CO₂. A further advantage of mixed gas is the higher quality, in particular notch toughness, compared with CO₂. For this reason, mixed gas is often recommended for welding low-alloy steels, such as creep-resistant steels, even in thicknesses greater than 1.5 mm. Mixed gas of the 80/20 type, in which the argon is of a lower purity, is also available. These gases are less expensive than those based on pure argon and can often be used with equally good results.

One drawback of Ar/CO₂ mixtures is that they lead to increased ozone formation, compared with pure CO₂, when used as shielding gas in arc welding.

Another drawback when using the mixture is that the current load capacity of the welding gun is reduced by about 30% compared with welding with CO₂.

Shielding Gas for Stainless and Heat-Resistant Steels

Argon containing 1% oxygen is normally used for welding stainless and heat-resistant steels, but argon containing 2% O₂ or 5% O₂ is also available. The latter produces a more fluid weld pool. A shielding gas which consists of 98% argon + 2% CO₂ has gained favour for MIG welding stainless steels. It can often replace argon/helium mixtures, which are used to help fusion when welding thick stainless steel, and can very often replace argon/oxygen mixtures.

Choice of Welding Process:

Short Arc or Spray Arc

The electrodes for gas metal arc welding listed in these pages are suitable for short arc welding in the smallest diameters and for spray arc welding in diameters 1.2-2.4 mm. Short arc welding (welding with short circuiting droplet transfer) can be carried out in all positions and is the best process for welding sheet material approximately 0.8-3 mm thick and for making the root run in prepared butt joints. Spray arc welding (welding with finely divided free flight drop transfer) is carried out at higher currents and voltages than short arc welding and is, therefore generally faster and more economical than short arc welding for plate thicknesses exceeding 2-3 mm. It is only used for welding in the horizontal or horizontal/vertical positions. The gas consumption is 6-10 litres/min for short arc welding and 12-20 litres/min for spray arc welding. The higher the welding current, the higher the gas flow required.

Welding Technique

The welding gun is normally held in the right hand, which means that the weld is made from right to left with the gun directed away from the deposited weld at an angle of 75-80° between the electrode and the workpiece, thereby giving the operator a good view of the weld pool and the joint. This produces a smoother weld bead than if the gun is directed towards the finished weld.

Abbreviations

MIG welding = metal inert gas welding
Metal arc welding in an atmosphere consisting mainly of an inert gas such as argon.

MAG welding = metal active gas welding
Metal arc welding in an atmosphere consisting of an active gas, usually carbon dioxide.
Gas mixtures containing 20% or more CO₂ are usually classified as active.

General Recommendations for Submerged Arc Welding

1. **The flux must be dry.** Agglomerated fluxes must be protected from moisture pick-up.

In tropical, humid areas, re-drying agglomerated fluxes at 250-350°C before use is recommended. The remaining flux in the welding machine container should be removed and stored in a dry cabinet and should therefore not be left in the open container during the night.

During the transport of fluxes, a maximum of two pallets should be stacked to prevent the grains being crushed.

2. The fusion faces and the plate in the vicinity of the joint should be clean and dry. The cleaner the joint, the better the chances of obtaining a satisfactory weld. Rust, mill scale, paint, oil and residue from arc-air gouging or grinding can adversely affect the quality of the weld metal. The more impurities on the fusion faces, the greater the risk of weld metal defects.

3. The arc voltage must be kept constant. Increased arc voltage results in higher flux consumption. If the flux contains alloying elements, the amount transferred to the weld metal will increase as the arc voltage increases.
4. As a general rule, multi-run deposits made at moderate welding currents have better mechanical properties than one- or two-layer deposits made at high currents in similar plate thicknesses.

The mechanical properties are obtained according to the welding conditions given in applicable standards such as EN ISO or AWS.

Other welding conditions may produce weld metal analyses and mechanical properties which differ from those given in the handbook.

Approval in Accordance with Classification Society Rules

Welding materials are normally classified by ESAB in accordance with a standard, e.g. AWS and EN ISO. To verify mechanical properties they are also approved in accordance with the rules of the classification societies.

Classification

The classification of welding products refers to standards and, when a welding product is classified, its type, properties and field of application are given. The manufacturer verifies the correct classification of a product by internal testing and/or by witness of an outside organisation.

Approval

Ship owners and partners in offshore enterprises require welding consumables to be approved in accordance with the rules of the classification societies. Approval is also required by clients in accordance with national or international standards for boiler and pressure vessels as well as other standards to be verified by an authorized approval institute.

Approved welding products are entered on the "List of Approved Welding Consumables" distributed annually by the societies and other institutes.

The ESAB Welding Handbook provides information about the welding position, current/polarity, low hydrogen and grading.

Non-Alloyed and Low-Alloyed Steels

Consumables are divided into three categories based on their tensile strength level:

Normal strength steel: indicated by the numbers 1, 2 or 3 (e.g. 3 3M) that the electrode is to be used in steel with a minimum yield strength (ReH) of 305 and a tensile strength of 400-560 MPa.

High strength steel: indicated by 2Y, 3Y, 4Y, 5Y (ReH min 375 and Rm 490-660 MPa) and 2Y40, 3Y40, 4Y40 (ReH min 400 and Rm 510-690 MPa).

Extra high strength steel: indicated by 3Y42, 4Y42, 5Y42 up to 5Y69 and so on for the different strength steel categories, where the numbers 42...69 symbolize a yield strength in MPa indicating that the electrodes can be used for extra high tensile steels.

Toughness Level

Each steel category is divided into three to five toughness levels represented by the first digit in the grade (1, 2, 3, 4 or 5)

- 1 suitable for grade A steel (impact tested at 20°C)
- 2 suitable for grade A, B and C steels (impact tested at 0°C)
- 3 suitable for grade A, B, D and E steels (impact tested at -20°C)
- 4 suitable for grade A, B, D, E and F steels (impact tested at -40°C)
- 5 suitable for grades A, B, D, E and F steels (impact tested at -60°C)

Other Frequently Used Abbreviations

- T** two-run welding (submerged arc welded with one run from eachside)
- M** multi-run welding (submerged arc or automatic gas-shielded arc welding)
- S** semi-automatic, gas-shielded and flux-cored arc welding

H5, H10, H15 low-hydrogen welding consumables

DP deep penetration

Stainless Steel and Other High-Content Alloyed Steels

Grades of stainless steel for which the welding consumable is approved are indicated with respect to one or more of the types of stainless steels: 304L, 304LN, 316LN and so on.

The abbreviation SS/CMn indicates approval for joining any of the austenitic types of stainless steel to any of the normal strength or higher tensile ship steels. Dup/CMn indicates approval for joining any of the duplex types of stainless steel to any of the normal strength or higher tensile ship steels.

The system described for grading the consumables in accordance with the rules of the classification societies changes as new steels appear on the market and sometimes there are changes to the approval ratings which might mean that the handbook may not be currently up-to-date. To ensure that valid information is used, please request the latest issued Product Data Sheet for the filler material or please look into the list of product type approvals of the marine society you need the approval from.

EN ISO 2560-A: for covered electrodes for manual arc welding of non-alloyed and fine grain steels

E 46 3 1Ni B 5 4 H5

Symbol for strength and elongation

Symbol	Min. Yield Strength ¹ , MPa	Tensile Strength, MPa	Min. Elongation ² , %
35	355	440-570	22
38	380	470-600	20
42	420	500-640	20
46	460	530-680	20
50	500	560-720	18

1 - For the yield strength the lower yield (R_{eL}) shall be used when yielding occurs, otherwise the 0.2% proof stress ($R_{p0.2}$) shall be used. 2 - $L_0 = 5d$

Symbol for impact properties

Symbol	Min. average impact energy 32 J °C
Z	no requirements
A	+20
0	0
2	-20
3	-30
4	-40
5	-50
6	-60

Symbol for chemical composition of all weld metal

Alloy Symbol	Chemical Composition ^{1,2,3} %		
	Mn	Mo	Ni
no symbol	2.0	-	-
Mo	1.4	0.3-0.6	-
MnMo	1.4-2.0	0.3-0.6	-
1Ni	1.4	-	0.6-1.2
2Ni	1.4	-	1.8-2.6
3Ni	1.4	-	2.6-3.8
Mn1Ni	1.4-2.0	-	0.6-1.2
Mn2Ni	1.4-2.0	1.2-2.6	1.2-2.6
1NiMo	1.4	0.3-0.6	0.6-1.2
Z	any other agreed composition		

1 - If not specified: Mo <0.2, Ni <0.3, Cr <0.2, V <0.05, Nb <0.05, Cu <0.3 (electrodes without gas shield only)

2 - Single values shown in the table mean maximum values

3 - The results shall be rounded to the same number of significant figures as in the specified value using the rules according to ISO 31-0, annex B Rule A.

Symbol for diffusible hydrogen

Symbol	Max. hydrogen content, ml/100g deposited weld metal
H 5	5
H 10	10
H 15	15

Symbol for the welding position

Welding positions in accordance with ISO 6947.

- 1: all positions
- 2: all positions, except vertical down
- 3: flat butt weld, flat fillet weld, horizontal/vertical weld
- 4: flat butt weld, flat fillet weld
- 5: as 3 and recommended vertical down welding

Symbol for recovery and type of current

Symbol	Weld metal recovery %	Type of current ²
1	≤105	AC + DC
2	≤105	DC
3	>105 ≤125	AC + DC
4	>105 ≤125	DC
5	>125 ≤160	AC + DC
6	>125 ≤160	DC
7	>160	AC + DC
8	>160	DC

1 - In order to demonstrate operability on ac, tests shall be carried out with no load voltage not higher than 65V.

2 - AC = alternation current DC = direct current

Symbol for the type of electrode covering

A	Acid
C	Cellulosic
R	Rutile
RC	Rutile-cellulosic
RA	Rutile-acid
RB	Rutile-basic
RR	Rutile-thick
B	Basic

EN ISO 18275 – A: for covered electrodes for manual metal arc welding of high-strengths steels.

E 55 4 MnMo B 3 2 H5

Symbol for strength and elongation

Symbol	Min. Yield Strength ¹ , MPa	Tensile Strength, MPa	Min. Elongation ² , %
55	550	610-780	18
62	620	690-890	18
69	690	760-960	17
79	790	880-1080	16
89	890	980-1180	15

1 - For the yield strength the lower yield ($R_{p0.2}$) shall be used when yielding occurs, otherwise the 0.2% proof stress ($R_{p0.2}$) shall be used.

2 - The gauge length is equal to five times the test specimen diameter

Symbol for impact properties

Symbol	Min. average impact energy 32 J °C
Z	no requirements
A	+20
0	0
2	-20
3	-30
4	-40
5	-50
6	-60
7	-70
8	-80

Symbol for chemical composition of all weld metal

Alloy Symbol	Chemical Composition ^{1,2} %			
	Mn	Ni	Cr	Mo
MnMo	1.4-2.0	-	-	0.3-0.6
Mn1Ni	1.4-2.0	0.6-1.2	-	-
1NiMo	1.4	0.6-1.2	-	0.3-0.6
1.5NiMo	1.4	1.2-1.8	-	0.3-0.6
2NiMo	1.4	1.8-2.6	-	0.3-0.6
Mn1NiMo	1.4-2.0	0.6-1.2	-	0.3-0.6
Mn2NiMo	1.4-2.0	1.8-2.6	-	0.3-0.6
Mn2NiCrMo	1.4-2.0	1.8-2.6	0.3-0.6	0.3-0.6
Mn2Ni1CrMo	1.4-2.0	1.8-2.6	0.6-1.0	0.3-0.6
Z ³	any other agreed composition			

1 - If not specified: Mo <0.2, Ni <0.3, Cr <0.2, V <0.05, Nb <0.05, Cu <0.3, C ≤ 0.10, P < 0.025, S < 0.020, Si < 0.80

2 - Single values shown in the table mean maximum values

3 - Consumables for which the chemical composition is not listed shall be symbolized similarly and prefixed by the letter Z. The chemical composition ranges are not specified and it is possible that two electrodes with the same Z classification are not interchangeable.

Symbol for diffusible hydrogen

Symbol	Max. hydrogen content, ml/100g deposited weld metal
H 5	5
H 10	10
H 15	15

Symbol for the welding position

Welding positions in accordance with ISO 6947.

- 1: all positions
- 2: all positions, except vertical down
- 3: flat butt weld, flat fillet weld, horizontal/vertical weld
- 4: flat butt weld, flat fillet weld
- 5: as 3 and recommended vertical down welding

Symbol for recovery and type of current

Symbol	Weld metal recovery %	Type of current ²
1	≤105	AC + DC
2	≤105	DC
3	>105	≤125 AC + DC
4	>105	≤125 DC
5	>125	≤160 AC + DC
6	>125	≤160 DC
7	>160	AC + DC
8	>160	DC

1 - In order to demonstrate operability on ac, tests shall be carried out with no load voltage not higher than 65V.

2 - AC = alternation current DC = direct current

Symbol for the type of electrode covering

B	Basic
---	-------

For other electrodes covering, consult ISO 2560-A.

The letter T indicates that strength, elongation and impact properties in the classification of the deposited weld metal are obtained after a post-weld heat treatment between 560 °C and 600 °C for 1 h. The test piece shall be left in the furnace to cool down to 300 °C.

EN ISO 14171-A: for flux/wire combinations

S 38 5				AB				S2Si		
S		Submerged arc welding								
Symbol for tensile properties				Chemical composition of flux						
Grade Designation	Min. Yield Strength ¹ , MPa	Tensile Strength, MPa	Elongation ² , %	Symbol	Type of flux					
35	355	440-570	22	MS	Manganese-silicate					
38	380	470-600	20	CS	Calcium-silicate					
42	420	500-640	20	ZS	Zirconium-silicate					
46	460	530-680	20	RS	Rutile-silicate					
50	500	560-720	18	AR	Aluminate-rutile					
				AB	Aluminate-basic					
				AS	Aluminate-silicate					
				AF	Aluminate-fluoride-basic					
				FB	Fluoride-basic					
				GS	Magnesium-silicate					
				Z	Any other composition					
Symbol	Minimum parent material yield strength, MPa	Minimum tensile strength of the welded joint, MPa		Symbol for impact properties						
2T	275	370		Grade Designation	Charpy-V Impact J (min)	Temp °C				
3T	355	470		Z	No requirements	-				
4T	420	520		A	47	20				
5T	500	600		0	47	0				
				2	47	-20				
				3	47	-30				
				4	47	-40				
				5	47	-50				
				6	47	-60				
				7	47	-70				
				8	47	-80				
All-weld chemical composition of FCAW										
Symbol	Chemical Composition %									
	Mn	Ni	Mo	Cu						
T3	1.4-2.0	-	-	0.3						
T3Ni1	1.4-2.0	0.6-1.2	-	0.3						
Type of wire according to EN ISO 14171-A and chemical composition of wire electrode										
Grade Designation	C	Si	Mn	Ni	Mo	Cr	Other Elements			
SZ	Any other agreed analysis									
S1	0.05-0.15	-0.15	0.35-0.60	-0.15	-0.15	-0.15	*			
S2	0.07-0.15	-0.15	0.80-1.30	-0.15	-0.15	-0.15	*			
S3	0.07-0.15	-0.15	1.30-1.75	-0.15	-0.15	-0.15	*			
S4	0.07-0.15	-0.15	1.75-2.25	-0.15	-0.15	-0.15	*			
S1Si	0.07-0.15	0.15-0.40	0.35-0.60	-0.15	-0.15	-0.15	*			
S2Si	0.07-0.15	0.15-0.40	0.80-1.30	-0.15	-0.15	-0.15	*			
S2Si2	0.07-0.15	0.40-0.60	0.80-1.20	-0.15	-0.15	-0.15	*			
S3Si	0.07-0.15	0.15-0.40	1.30-1.85	-0.15	-0.15	-0.15	*			
S4Si	0.07-0.15	0.15-0.40	1.85-2.25	-0.15	-0.15	-0.15	*			
S1Mo	0.05-0.15	0.05-0.25	0.35-0.60	-0.15	0.45-0.65	-0.15	*			
S2Mo	0.07-0.15	0.05-0.25	0.80-1.30	-0.15	0.45-0.65	-0.15	*			
S2MoTiB	0.05-0.15	0.15-0.35	1.00-1.35	-	0.40-0.65	-	**			
S3Mo	0.07-0.15	0.05-0.25	1.30-1.75	-0.15	0.45-0.65	-0.15	*			
S4Mo	0.07-0.15	0.05-0.25	1.75-2.25	-0.15	0.45-0.65	-0.15	*			
S2Ni1	0.07-0.15	0.05-0.25	0.80-1.30	0.80-1.20	-0.15	-0.15	*			
S2Ni1.5	0.07-0.15	0.05-0.25	0.80-1.30	1.20-1.80	-0.15	-0.15	*			
S2Ni2	0.07-0.15	0.05-0.25	0.80-1.30	1.80-2.40	-0.15	-0.15	*			
S2Ni3	0.07-0.15	0.05-0.25	0.80-1.30	2.80-3.70	-0.15	-0.15	*			
S2Ni1Mo	0.07-0.15	0.05-0.25	0.80-1.30	0.80-1.20	0.45-0.65	-0.20	*			
S3Ni1.5	0.07-0.15	0.05-0.25	1.30-1.70	1.20-1.80	-0.15	-0.20	*			
S3Ni1Mo	0.07-0.15	0.05-0.25	1.30-1.80	0.80-1.20	0.45-0.65	-0.20	*			
S3Ni1Mo0.2	0.07-0.15	0.10-0.35	1.20-1.60	0.80-1.20	0.15-0.30	-0.15	P, S: -0.015			
S3Ni1.5Mo	0.07-0.15	0.05-0.25	1.20-1.80	1.20-1.80	0.30-0.50	-0.20	*			
S2Ni1Cu	0.06-0.12	0.15-0.35	0.70-1.20	0.65-0.90	0.15	-0.40	Cu: 0.40-0.65			
S3Ni1Cu	0.05-0.15	0.15-0.40	1.20-1.70	0.60-1.20	0.15	-0.15	Cu: 0.30-0.60			

* Cu: -0.30 P, S: 0.025 or 0.020 Al: -0.030 ** Ti: 0.10-0.20 B: 0.005-0.020

EN ISO 17632: for Cored Wires

T 46 3 1Ni B M 4 H5

Symbol for strength and elongation

Symbol	Min. Yield Strength ¹ , MPa	Tensile Strength, MPa	Min. Elongation ² , %
35	355	440-570	22
38	380	470-600	20
42	420	500-640	20
46	460	530-680	20
50	500	560-720	18

1 - For the yield strength the lower yield ($R_{p0.2}$) shall be used when yielding occurs, otherwise the 0.2% proof stress ($R_{m0.2}$) shall be used. 2 - $L_0 = 5d$

Symbol for impact properties

Symbol	Min. average impact energy 47J °C
Z	no requirements
A	+20
0	0
2	-20
3	-30
4	-40
5	-50
6	-60

Symbol for chemical composition of all weld metal

Alloy Symbol	Chemical Composition ²³ %		
	Mn	Mo	Ni
no symbol	2.0	-	-
Mo	1.4	0.3-0.6	-
MnMo	> 1.4-2.0	0.3-0.6	-
1Ni	1.4	-	0.6-1.2
2Ni	1.4	-	1.8-2.6
3Ni	1.4	-	> 2.6-3.8
Mn1Ni	> 1.4-2.0	-	0.6-1.2
1NiMo	1.4	0.3-0.6	0.6-1.2
Z	any other agreed composition		

1 - If not specified: Mo <0.2, Ni <0.3, Cr <0.2, V <0.05, Nb <0.05, Cu <0.3 (electrodes without gas shield only)

2 - Single values shown in the table mean maximum values

3 - The results shall be rounded to the same number of significant figures as in the specified value using the rules according to ISO 31-0, annex B Rule A.

Symbol for diffusible hydrogen

Symbol	Max. hydrogen content, ml/100g deposited weld metal
H 5	5
H 10	10
H 15	15

Symbol for the welding position

The welding positions are symbolised by a digit designating the positions for which the electrode is tested according to prEN-3 (00121205)

- 1: all positions
- 2: all positions, except vertical down
- 3: flat butt weld, flat fillet weld, horizontal/vertical weld
- 4: flat butt weld, flat fillet weld
- 5: as 3 and recommended vertical down welding

Shielding gas

EN 758 symbol	
M	Argon mixture
C	CO ₂
N	No shielding gas

Description of core

Gas-Shielded	
R	Rutile base, slow freezing slag
P	Rutile base, fast freezing slag
B	Basic slag
M	Metal powder core
Self-Shielded	
U	
V	Rutile of basic/fluoride
W	Basic/fluoride, slow freezing slag
X	
Y	Basic/fluoride, fast freezing slag
Z	Other types
S	

EN ISO 14174: for fluxes

S A AB 1 67 AC H5

S	Submerged arc welding
ES	Electroslag welding

Method of manufacture	
Symbol	
F	Fused flux
A	Agglomerated flux
M	Mixed flux

Hydrogen content of deposited metal	
Symbol	Max. hydrogen content, ml/100g deposited weld metal
H 2	2
H 4	4
H 5	5
H 10	10

Chemical composition of flux

Symbol	Type of flux
MS	Manganese-silicate
CS	Calcium-silicate
ZS	Zirconium-silicate
RS	Rutile-silicate
AR	Aluminate-rutile
AB	Aluminate-basic
AS	Aluminate-silicate
AF	Aluminate-fluoride-basic
FB	Fluoride-basic
GS	Magnesium-silicate
Z	Any other composition

Type of current	
Symbol	
DC	Direct current only
AC	Alternating and direct current

Application

Class	
1	SA welding of non alloy and low alloy steels
2 and 2B	Fluxes for joining and surfacing of/with stainless and heat resisting Cr and Cr-Ni steels and/or Ni and Ni-based alloys. 2B for fluxes especially for strip cladding.
3	Fluxes for hardfacing overlay welding which alloy elements such as C, Cr or Mo to the weld metal.
4	Other fluxes which do not fit in class 1 to 3, e.g. fluxes for backing in one-side welding applications.

Metallurgical behaviour, flux class 1

Symbol	Metallurgical behaviour	Contribution from flux
1	Burn-out	>0.7
2	Burn-out	0.5-0.7
3	Burn-out	0.3-.05
4	Burn-out	0.1-0.3
5	Neutral	0.0-0.1
6	Pick-up	0.1-0.3
7	Pick-up	0.3-0.5
8	Pick-up	0.5-.07
9	Pick-up	>0.7
Sequence	Si, then Mn	

Metallurgical behaviour, flux class 2 and class 2B

Symbol	Metallurgical Behaviour	Chemical Composition ¹²³ %			
		C	Si	Cr	Nb
1	Burn-out	>0.020	>0.7	>2.0	>0.20
2	Burn-out	-	0.5-0.7	1.5-2.0	0.15-1.20
3	Burn-out	0.010-0.020	0.3-0.5	1.0-1.5	0.10-0.15
4	Burn-out	-	0.1-0.3	0.5-1.0	0.05-0.10
5	Neutral	0.000-0.010	0.0-0.1	0.0-0.5	0.00-0.05
6	Pick-up	-	0.1-0.3	0.5-1.0	0.05-0.10
7	Pick-up	0.010-0.020	0.3-0.5	1.0-1.5	0.10-0.15
8	Pick-up	-	0.5-0.7	1.5-2.0	0.15-0.20
9	Pick-up	>0.020	>0.7	>2.0	>2.0
Sequence	C, Si, then Cr, Nb (then other elements if applicable)				

Metallurgical behaviour, flux class 3 and class 4

Class 3	Stating chemical symbols of alloying elements (e.g. C, Cr, Mo) and approximate amount (without the % symbol).
Class 4	Stating chemical symbols of alloying elements

SFA/AWS A5.17: specification for carbon steel electrodes and fluxes for submerged arc welding

F 7 A 5 - EM12K

F	Submerged arc welding flux
---	----------------------------

Symbol for strength and elongation

Symbol	Min. Yield Strength, MPa	Tensile Strength, MPa	Min. Elongation, %
6	330	415 - 550	22
7	400	480 - 650	22

Symbol for heat treatment

Symbol	
A	As Welded
P	Postweld heat treated (PWHT); 620°C / 1h

Symbol for impact properties

Symbol	Min. average impact energy 27J °C
0	-18
2	-29
4	-40
5	-46
6	-51
8	-62
Z	no requirements

Symbol for chemical composition of wire electrodes

Symbol	Chemical Composition %					
	C	Mn	Si	S	P	Cu (including Cu-coating)
EL12	0.04-0.14	0.25-0.60	0.10	0.030	0.030	0.35
EM12	0.06-0.15	0.80-1.25	0.10	0.030	0.030	0.35
EM12K	0.05-0.15	0.80-1.25	0.10-0.35	0.030	0.030	0.35
EH12K	0.06-0.15	1.50-2.00	0.25-0.65	0.025	0.025	0.35
EH14	0.10-0.20	1.70-2.20	0.10	0.030	0.030	0.35

Single values are maximum.

Symbol for chemical composition for composite electrode weld metal

Symbol	Chemical Composition %					
	C	Mn	Si	S	P	Cu
EC1	0.15	1.80	0.90	0.035	0.035	0.35
ECG	Not specified					

Single values are maximum.

EN ISO 24598-A: welding consumables - solid wire electrodes, tubular cored electrodes and electrode/flux combinations for submerged arc welding of creep-resisting steels

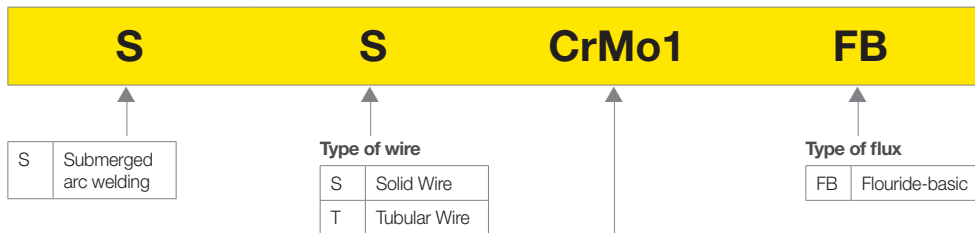

Chemical composition of solid wire electrodes for submerged arc welding (extract of table)

Symbol	Chemical Composition ¹²³ %										
	C	Si	Mn	P	S	Cr	Ni	Mo	Cu	V	Other
Mo	0.08-0.15	0.05-0.25	0.80-1.20	0.025	0.025	0.2	0.3	0.45-0.65	0.030	0.3	Nb: 0.01
MnMo	0.08-0.15	0.05-0.25	1.30-1.70	0.025	0.025	0.2	0.3	0.45-0.65	0.030	0.3	Nb: 0.01
CrMo1	0.08-0.15	0.05-0.25	0.60-1.00	0.020	0.020	0.90-1.30	0.3	0.40-0.65	0.030	0.3	Nb: 0.01
CrMo2	0.08-0.15	0.05-0.25	0.30-0.70	0.020	0.020	2.2-2.8	0.3	0.90-1.15	0.025	0.3	Nb: 0.01
CrMo5	0.03-0.10	0.20-0.50	0.40-0.75	0.020	0.020	5.5-6.5	0.3	0.50-0.80	0.030	0.3	Nb: 0.01
CrMo91	0.07-0.15	0.60	0.4-1.5	0.020	0.020	8.0-10.5	0.4-1.0	0.80-1.20	0.025	0.15-0.30	Nb: 0.03-0.10 N: 0.02-0.07
Z	Any other agreed composition.										
Single values shown in the table are maximum values.											

Chemical composition for all weld metal deposits (extract of table)

Symbol	Chemical Composition ¹²³ %										
	C	Si	Mn	P	S	Cr	Ni	Mo	Cu	V	Other
Mo	0.15	0.80	1.4	0.030	0.030	0.2	0.3	0.45-0.65	0.35	0.3	Nb: 0.01
MnMo	0.15	0.80	2.0	0.030	0.030	0.2	0.3	0.45-0.65	0.35	0.3	Nb: 0.01
CrMo1	0.15	0.80	1.20	0.030	0.030	0.80-1.30	0.25	0.35-0.65	0.40	0.3	Nb: 0.01
CrMo2	0.15	0.80	1.20	0.030	0.030	2.2-2.8	0.3	0.80-1.15	0.35	0.3	Nb: 0.01
CrMo5	0.10	0.80	1.20	0.030	0.030	4.5-6.5	0.3	0.45-0.80	0.35	0.3	Nb: 0.01
CrMo91	0.15	0.80	1.80	0.030	0.030	8.0-10.5	1.0	0.70-1.20	0.35	0.10-0.30	Nb: 0.02-0.10 N: 0.02-0.07
Z	Any other agreed composition.										
Single values shown in the table are maximum values.											

Mechanical properties of all weld metal deposits (Extract of table)

Symbol	Min. Yield Strength ¹ , MPa	Min. Tensile Strength, MPa	Min. Elongation ² , %	Min. Toughness at 20°C		Heat Treatment		
				Average of 3, J	Single Value, J	Preheat interpass, °C	PWHT Temp °C	PWHT Time, minutes
Mo	355	510	22	47	38	<200	-	-
MnMo	355	510	22	47	38	<200	-	-
CrMo1	355	510	20	47	38	150-250	660-700	60
CrMo2	400	500	18	47	38	200-300	690-750	60
CrMo5	400	590	17	47	38	200-300	730-760	60
CrMo91	415	585	17	47	38	250-350	750-760	180
Z	Any other agreed composition.							

SFA/AWS A5.23: specification for low-alloy steel electrodes and fluxes for submerged arc welding - two-run classification system

F 8T A 6 - EA2TiB

S	Submerged arc welding flux
---	----------------------------

Symbol for strength and elongation, two-run (T)

Symbol	Yield Strength ¹ , MPa	Tensile Strength, MPa	Min. Elongation ¹ , %
6T	340	410	22
7T	410	480	22
8T	480	550	20
9T	550	620	17
10T	620	690	16
11T	690	760	15
12T	760	830	14
13T	830	900	14

All values are minimum requirements.

Symbol for heat treatment

Symbol	
A	As Welded
P	Postweld heat treated (PWHT); depending on alloy, 620°C, 690°C and other temp. / 1h

Symbol for impact properties

Symbol	Min. average impact energy 27J °C
0	-18
2	-29
4	-40
5	-46
6	-51
8	-62
10	-73
15	-101
Z	no requirements

Chemical composition of solid wire electrodes for submerged arc welding (extract of table)

Symbol	Chemical Composition ¹²³ %									
	C	Mn	Si	S	P	Cr	Ni	Mo	Cu (incl Cu-coating)	Other
EA2	0.05-0.17	0.95-1.35	0.20	0.025	0.025	-	-	0.45-0.65	0.35	-
EA2TiB	0.05-0.17	0.95-1.35	0.35	0.025	0.025	-	-	0.45-0.65	0.35	see 1
EA4	0.05-0.17	1.20-1.70	0.20	0.025	0.025	-	-	0.45-0.65	0.35	-
EB2R	0.07-0.15	0.45-1.00	0.05-0.30	0.010	0.010	1.00-1.75	-	0.45-0.65	0.15	see 2
EB3R	0.05-0.15	0.40-0.80	0.05-0.30	0.010	0.010	2.25-3.00	-	0.90-1.00	0.15	see 2
EB6	0.10	0.35-0.70	0.05-0.50	0.025	0.025	4.50-6.50	-	0.45-0.70	0.35	-
EB91	0.07-0.13	1.25	0.50	0.010	0.010	8.50-10.50	1.00	0.85-1.15	0.10	see 3
ENi1	0.12	0.75-1.25	0.05-0.30	0.020	0.020	0.15	0.75-1.25	0.30	0.35	-
ENi2	0.12	0.75-12.5	0.05-0.30	0.020	0.020	-	2.10-2.90	-	0.35	-
ENi3	0.13	0.60-1.20	0.05-0.30	0.020	0.020	0.15	3.10-3.80	-	0.35	-
ENi6	0.07-0.15	1.20-1.60	0.05-0.30	0.020	0.020	-	0.75-1.25	0.10-0.30	0.35	-
EG	not specified									
(EC)	(composite electrode)									

Single values are maximum.
 1.) Ti: 0.05-0.30; B: 0.005 - 0.030 2) As: 0.005; Sn: 0.005; Sb: 0.005 3) V: 0.15-0.25; Nb: 0.02-0.10; N: 0.03-0.07; Al: 0.04

SFA/AWS A5.23: specification for low-alloy steel electrodes and fluxes for submerged arc welding - multiple pass classification system

F 8 A 10 - ENi6 - Ni6

F	Submerged arc welding flux
---	----------------------------

Symbol for strength and elongation

Symbol	Min. Yield Strength ¹ , MPa	Tensile Strength, MPa	Min. Elongation ² , %
7	400	480-650	22
8	470	550-690	20
9	540	620-760	17
10	610	690-830	16
11	680	760-900	15
12	740	830-870	14
13	810	900-1030	14

Symbol for impact properties

Symbol	Min. average impact energy 27J °C
0	-18
2	-29
4	-40
5	-46
6	-51
8	-62
10	-73
15	-101
Z	no requirements

Symbol for heat treatment

Symbol	
A	As Welded
P	Postweld heat treated (PWHT); depending on alloy, 620°C, 690°C and other temp. / 1h (B91: 2h)

Chemical composition of solid wire electrodes for submerged arc welding (extract of table)

Symbol	Chemical Composition ¹²³ %									
	C	Mn	Si	S	P	Cr	Ni	Mo	Cu (incl Cu-coating)	Other
EA2	0.05-0.17	0.95-1.35	0.20	0.025	0.025	-	-	0.45-0.65	0.35	-
EA2TiB	0.05-0.17	0.95-1.35	0.35	0.025	0.025	-	-	0.45-0.65	0.35	see 1
EA4	0.05-0.17	1.20-1.70	0.20	0.025	0.025	-	-	0.45-0.65	0.35	-
EB2R	0.07-0.15	0.45-1.00	0.05-0.30	0.010	0.010	1.00-1.75	-	0.45-0.65	0.15	see 2
EB3R	0.05-0.15	0.40-0.80	0.05-0.30	0.010	0.010	2.25-3.00	-	0.90-1.00	0.15	see 2
EB6	0.10	0.35-0.70	0.05-0.50	0.025	0.025	4.50-6.50	-	0.45-0.70	0.35	-
EB91	0.07-0.13	1.25	0.50	0.010	0.010	8.50-10.50	1.00	0.85-1.15	0.10	see 3
ENi1	0.12	0.75-1.25	0.05-0.30	0.020	0.020	0.15	0.75-1.25	0.30	0.35	-
ENi2	0.12	0.75-12.5	0.05-0.30	0.020	0.020	-	2.10-2.90	-	0.35	-
ENi3	0.13	0.60-1.20	0.05-0.30	0.020	0.020	0.15	3.10-3.80	-	0.35	-
ENi6	0.07-0.15	1.20-1.60	0.05-0.30	0.020	0.020	-	0.75-1.25	0.10-0.30	0.35	-
EG	not specified									
(EC)	(composite electrode)									
Single values shown in the table are maximum values.										
1) Ti: 0.05-0.30; B: 0.005-0.030 2) As: 0.005; Sn: 0.005; Sb: 0.005 3) V: 0.15 - 0.25; Nb: 0.02 - 0.10; N: 0.03 - 0.07; Al: 0.04										

Chemical composition of weld metal (extract of complete table)

Symbol	Chemical Composition ¹²³ %									
	C	Mn	Si	S	P	Cr	Ni	Mo	Cu (incl Cu-coating)	Other
A2	0.12	1.40	0.80	0.030	0.030	-	-	0.40-0.65	0.35	-
A3	0.15	2.10	0.80	0.030	0.030	-	-	0.40-0.65	0.35	-
A4	0.15	1.60	0.80	0.030	0.030	-	-	0.40-0.65	0.35	-
B2	0.05-0.15	1.20	0.80	0.030	0.030	1.00-1.50	-	0.40-0.65	0.35	-
B2R	0.05-0.15	1.20	0.80	0.010	0.010	1.00-1.50	-	0.40-0.65	0.15	see 1
B3	0.05-0.15	1.20	0.80	0.030	0.030	2.00-2.50	-	0.90-1.20	0.35	-
B3R	0.05-0.15	1.20	0.80	0.010	0.010	2.00-2.50	-	0.90-1.20	0.15	see 1
B91	0.08-0.13	1.20	0.80	0.010	0.010	8.0-10.5	0.80	0.85-1.20	0.25	see 2
Ni1	0.12	1.60	0.80	0.025	0.030	0.15	0.75-1.10	0.24	0.35	see 3
Ni2	0.12	1.60	0.80	0.025	0.030	-	2.00-2.90	-	0.35	-
Ni3	0.12	1.60	0.80	0.025	0.030	0.15	2.80-3.80	-	0.35	-
Ni6	0.14	1.60	0.80	0.025	0.030	-	0.70-1.10	0.10-0.35	0.35	-
F3	0.17	1.25-2.25	0.80	0.030	0.030	-	0.70-1.10	0.40-0.65	0.35	-
G	as agreed between supplier and purchaser									
(EC)	(composite electrode)									
Single values are maximum.										
Weld metals generated with a composite electrode have the prefix "EC" before the appropriate electrode description.										
1) As: 0.005; Sn: 0.005; Sb: 0.005 2) Mn+Ni = 1.40 max; Nb: 0.02 - 0.10; N: 0.02-0.07; V: 0.15-0.25; Al: 0.04 3) Ti+V+Zr: 0.05										

SFA/AWS A5.39: specification for flux and electrode combinations for submerged arc and electroslag joining and surfacing of stainless steel and nickel alloys - joining section

F 860 A 6 - ER2594 - 2594

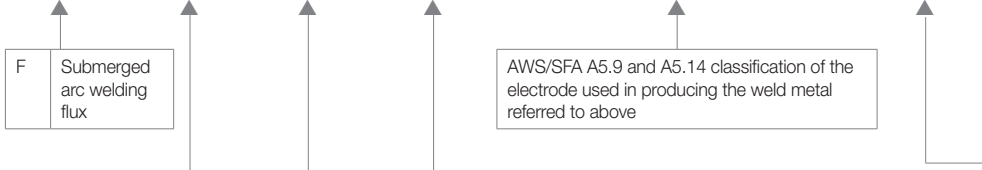

F Submerged arc welding flux

AWS/SFA A5.9 and A5.14 classification of the electrode used in producing the weld metal referred to above

Symbol for strength
identifies the minimum tensile strength in MPa. Yield strength at 0.2% offset and elongation are not specified.

Symbol for heat treatment

Symbol	
A	As Welded
P	Postweld heat treated (PWHT); temperature and holding time depending on the alloy

Symbol for impact properties

Symbol	Maximum test temperature (°C)	Minimum lateral expansion (mm)	Minimum average energy level (J)
Y	+20	Not required	Not required
0	0		
2	-20		
3	-30		
4	-40		
5	-50		
6	-50		
7	-70		
10	-100		
20	-196		
Z		No impact or lateral expansion requirements	

Chemical composition requirements for stainless and nickel-alloy electrodes and rods

Traditional AWS A5.9 Alloy Designation	Chemical Composition %											Element	Amount
	C	Cr	Ni	Mo	Mn	Si	P	S	Cu				
309LMo	0.03	23.0-25.0	12.0-14.0	2.0-3.0	1.0-2.5	0.30-0.65	0.03	0.03	0.75	-	-	-	
309LNb	0.03	23.0-25.0	12.0-14.0	0.75	1.0-2.5	0.65	0.03	0.03	0.75	Nb	10xC to 1.0; 0.2 min.	-	
310	0.08-0.15	25.0-28.0	20.0-22.5	0.75	1.0-2.5	0.30-0.65	0.03	0.03	0.75	-	-	-	
312	0.15	28.0-32.0	8.0-10.5	.075	1.0-2.5	0.30-0.65	0.03	0.03	0.75	-	-	-	
316H	0.04-0.08	18.0-20.0	11.0-14.0	2.0-3.0	1.0-2.5	0.30-0.65	0.03	0.03	0.75	-	-	-	
316L	0.03	18.0-20.0	11.0-14.0	2.0-3.0	1.0-2.5	0.30-0.65	0.03	0.03	0.75	-	-	-	

Chemical composition requirements for nickel and nickel-alloy electrodes and rods

AWS Classification	UNS Number	Chemical Composition %														Other Elements Total		
		C	Mn	Fe	P	S	Si	Cu	Ni	Co	Al	Ti	Cr	Nb+Ta	Mo		V	W
ERNiCrMo-3	N06625	0.10	0.50	5.0	0.02	0.015	0.50	0.50	58.0 min	-	0.40	0.40	20.0-23.0	3.15-4.15	8.0-10.0	-	-	0.50
ERNiCrMo-4	N10276	0.02	1.0	4.0-7.0	0.04	0.03	0.08	0.5	Rem	2.5	-	-	14.5-16.5	-	15.0-17.0	0.35	3.0-4.5	0.50

Indicates the chemical composition of the weld metal obtained with the flux and electrode

Weld Metal Designation	Weight %																			
	C		Mn		P		S		Si		Cr		Ni		Mo		Nb+Ta		Cu	
	min	max	min	max	min	max	min	max	min	max	min	max	min	max	min	max	min	max	min	max
308H	0.04	0.08	0.5	2.5	-	0.04	-	0.03	-	1.0	18.0	22.0	8.0	10.7	0.5	1.5	-	-	-	0.75
308L	-	0.04	0.5	2.5	-	0.04	-	0.03	-	1.0	18.0	22.0	9.0	11.0	-	0.75	-	-	-	0.75
309L	-	0.04	0.5	2.5	-	0.04	-	0.03	-	1.0	22.0	25.0	12.0	14.0	-	0.75	-	-	-	0.75
309LMo	-	0.04	0.5	2.5	-	0.04	-	0.03	-	1.0	21.0	25.0	12.0	16.0	2.0	3.0	-	-	-	0.75
309LNb	-	0.04	0.5	2.5	-	0.04	-	0.03	-	1.0	22.0	25.5	12.0	14.0	-	0.75	0.2 and 10xC	1.0	-	0.75
310	-	0.20	1.0	2.5	-	0.03	-	0.03	-	1.0	25.0	28.0	20.0	22.5	-	0.75	-	-	-	0.75
312	-	0.15	0.5	2.5	-	0.04	-	0.03	-	1.0	28.0	32.0	8.0	10.5	-	0.75	-	-	-	0.75
316H	0.04	0.08	0.5	2.5	-	0.04	-	0.03	-	1.0	17.0	20.0	11.0	14.0	2.0	3.0	-	-	-	0.75
316L	-	0.04	0.5	2.5	-	0.04	-	0.03	-	1.0	17.0	20.0	11.0	14.0	2.0	3.0	-	-	-	0.75

SFA/AWS A5.39: specification for flux and electrode combinations for submerged arc and electroslag joining and surfacing of stainless steel and nickel alloys - surfacing section

ES CLAD 1 - EQ309LMo / 316L

Symbol	
SA	Submerged arc flux
ES	Electroslag flux

CLAD: indicates that this is a cladding classification

The digit 1 or 2 indicates that the chemical composition was achieved

Symbol	
1	after 1 layer of cladding
2	after 2 layers of cladding

AWS/SFA A5.9 and A5.14 classification of the electrode used in producing the weld metal referred to above

Chemical composition requirements for stainless and nickel-alloy electrodes and rods

Traditional AWS A5.9 Alloy Designation	Chemical Composition %										Element	Amount
	C	Cr	Ni	Mo	Mn	Si	P	S	Cu			
309LMo	0.03	23.0-25.0	12.0-14.0	2.0-3.0	1.0-2.5	0.30-0.65	0.03	0.03	0.75	-	-	
309LNb	0.03	23.0-25.0	12.0-14.0	0.75	1.0-2.5	0.65	0.03	0.03	0.75	Nb	10xC to 1.0; 0.2 min.	
310	0.08-0.15	25.0-28.0	20.0-22.5	0.75	1.0-2.5	0.30-0.65	0.03	0.03	0.75	-	-	
312	0.15	28.0-32.0	8.0-10.5	.075	1.0-2.5	0.30-0.65	0.03	0.03	0.75	-	-	
316H	0.04-0.08	18.0-20.0	11.0-14.0	2.0-3.0	1.0-2.5	0.30-0.65	0.03	0.03	0.75	-	-	
316L	0.03	18.0-20.0	11.0-14.0	2.0-3.0	1.0-2.5	0.30-0.65	0.03	0.03	0.75	-	-	

Chemical composition requirements for nickel and nickel-alloy electrodes and rods

AWS Classification	UNS Number	Chemical Composition %														Other Elements Total		
		C	Mn	Fe	P	S	Si	Cu	Ni	Co	Al	Ti	Cr	Nb+Ta	Mo		V	W
ERNiCrMo-3	N06625	0.10	0.50	5.0	0.02	0.015	0.50	0.50	58.0 min	-	0.40	0.40	20.0-23.0	3.15-4.15	8.0-10.0	-	-	0.50
ERNiCrMo-4	N10276	0.02	1.0	4.0-7.0	0.04	0.03	0.08	0.5	Rem	2.5	-	-	14.5-16.5	-	15.0-17.0	0.35	3.0-4.5	0.50

Indicates the chemical composition of the weld metal obtained with the flux and electrode

Weld Metal Designation	Weight %																					
	C		Mn		P		S		Si		Cr		Ni		Mo		Nb+Ta		Cu			
	min	max	min	max	min	max	min	max	min	max	min	max	min	max	min	max	min	max	min	max	min	max
308H	0.04	0.08	0.5	2.5	-	0.04	-	0.03	-	1.0	18.0	22.0	8.0	10.7	0.5	1.5	-	-	-	-	0.75	
308L	-	0.04	0.5	2.5	-	0.04	-	0.03	-	1.0	18.0	22.0	9.0	11.0	-	0.75	-	-	-	-	0.75	
309L	-	0.04	0.5	2.5	-	0.04	-	0.03	-	1.0	22.0	25.0	12.0	14.0	-	0.75	-	-	-	-	0.75	
309LMo	-	0.04	0.5	2.5	-	0.04	-	0.03	-	1.0	21.0	25.0	12.0	16.0	2.0	3.0	-	-	-	-	0.75	
309LNb	-	0.04	0.5	2.5	-	0.04	-	0.03	-	1.0	22.0	25.5	12.0	14.0	-	0.75	0.2 and 10xC	1.0	-	-	0.75	
310	-	0.20	1.0	2.5	-	0.03	-	0.03	-	1.0	25.0	28.0	20.0	22.5	-	0.75	-	-	-	-	0.75	
312	-	0.15	0.5	2.5	-	0.04	-	0.03	-	1.0	28.0	32.0	8.0	10.5	-	0.75	-	-	-	-	0.75	
316H	0.04	0.08	0.5	2.5	-	0.04	-	0.03	-	1.0	17.0	20.0	11.0	14.0	2.0	3.0	-	-	-	-	0.75	
316L	-	0.04	0.5	2.5	-	0.04	-	0.03	-	1.0	17.0	20.0	11.0	14.0	2.0	3.0	-	-	-	-	0.75	

EN ISO 26304-A: welding consumables – solid wire electrodes, tubular cored electrodes and electrode-flux-combinations for saw of high strength steels

S 55 6 FB - S3Ni1Mo

S Submerged arc welding flux

Symbol for strength and elongation, two-run (T)

Symbol	Min. Yield Strength ¹ , MPa	Tensile Strength, MPa	Min. Elongation ² , %
55	550	640-820	18
62	620	700-890	18
69	690	770-940	17
79	790	880-1080	16
89	890	940-1180	15

Symbol for impact properties

Symbol	Min. average impact energy 47J °C
A	20
0	0
2	-20
3	-30
4	-40
5	-50
6	-60
Z	no requirements

Chemical composition of flux

Symbol	Type of flux
MS	Manganese-silicate
CS	Calcium-silicate
ZS	Zirconium-silicate
RS	Rutile-silicate
AR	Aluminate-rutile
AB	Aluminate-basic
AS	Aluminate-silicate
AF	Aluminate-fluoride-basic
FB	Fluoride-basic
GS	Magnesium-silicate
Z	Any other composition

Chemical composition of solid wire electrodes for submerged arc welding (extract of table)

Symbol	Chemical Composition ^{1,2} %									
	C	Si	Mn	P	S	Cr	Ni	Mo	Cu	Other
S2Ni1Mo	0.07-0.15	0.05-0.25	0.80-1.30	0.020	0.020	0.20	0.80-1.20	0.45-0.65	0.30	0.50
S3Ni1Mo	0.07-0.15	0.05-0.35	1.30-1.80	0.020	0.020	0.20	0.80-1.20	0.45-0.65	0.30	0.50
S2Ni2Mo	0.05-0.09	0.15	1.10-1.40	0.015	0.015	0.15	2.00-2.50	0.45-0.60	0.30	0.50
S2Ni3Mo	0.08-0.12	0.10-0.25	0.80-1.20	0.020	0.020	0.15	2.80-3.20	0.10-0.25	0.30	0.50
S1Ni2, 5CrMo	0.07-0.15	0.10-0.25	0.45-0.75	0.020	0.020	0.50-0.85	2.10-2.60	0.40-0.70	0.30	0.50
S3Ni2, 5CrMo	0.07-0.15	0.10-0.25	1.20-1.80	0.020	0.020	0.30-0.85	2.00-2.60	0.40-0.70	0.30	0.50
S3Ni1, 5CrMo	0.07-0.14	0.05-0.15	1.30-1.50	0.020	0.020	0.15-0.35	1.50-1.70	0.30-0.50	0.30	0.50
S3Ni1, 5Mo	0.07-0.15	0.05-0.25	1.20-1.80	0.020	0.020	0.20	1.20-1.80	0.30-0.50	0.30	0.50
S4Ni2CrMo	0.08-0.11	0.30-0.40	1.80-2.00	0.015	0.015	0.85-1.00	2.10-2.60	0.55-0.70	0.30	0.50

SZ any other agreed composition

(EC) (composite electrode)

1) Al, Sn, As and Sb \leq 0.02% each and Ti, Pb and N \leq 0.01%

2) Cu: Including the cu-coating

3) Single vales shown in the table are maximum values.

EN ISO 14343-A: welding consumables - wire electrodes, strip electrodes, wires and rods for arc welding of stainless and heat-resisting steels (extract)

S 19 9 L (308L)

G	Gas metal arc welding
W	Gas tungsten arc welding
P	Plasma arc welding
S	Submerged arc welding
B	Strip cladding
L	Laser beam welding

The nominal chemical composition of wire or rod

Chemical composition of alloy type

Nominal composition	Alloy Type	Chemical Composition in %										
		C	Si	Mn	P	S	Cr	Ni	Mo	N	Cu	Other
19 9 L	308L	0.03	0.65	1.0-2.5	0.03	0.02	19.0-21.0	9.0-11.0	0.5	-	0.5	-
		0.03	0.65	1.0-2.5	0.03	0.03	19.5-22.0	9.0-11.0	0.75	-	0.75	-
19 9 H	308H	0.04-0.08	1.0	1.0-2.5	0.03	0.02	18.0-21.0	9.0-11.0	0.5	-	0.5	-
		0.04-0.08	0.65	1.0-2.5	0.03	0.03	19.5-22.0	9.0-11.0	0.5	-	0.75	-
18 8 Mn		0.20	1.2	5.0-8.0	0.03	0.03	17.0-20.0	7.0-10.0	0.5	-	0.5	-
23 12 L	309L	0.03	0.65	1.0-2.5	0.03	0.02	22.0-25.0	11.0-14.0	0.5	-	0.5	-
		0.03	0.65	1.0-2.5	0.03	0.03	23.0-25.0	12.0-14.0	0.75	-	0.75	-
23 12 2 L	309L Mo	0.03	1.0	1.0-2.5	0.03	0.02	21.0-25.0	11.0-15.5	2.0-3.5	-	0.5	-
		0.03	0.65	1.0-2.5	0.03	0.03	23.0-25.0	12.0-14.0	2.0-3.0	-	0.75	-
25 20	310	0.08-0.15	2.0	1.0-2.5	0.03	0.02	24.0-27.0	18.0-22.0	0.5	-	0.5	-
		0.08-0.15	0.65	1.0-2.5	0.03	0.03	25.0-28.0	20.0-22.5	0.75	-	0.75	-
29 9	312	0.15	1.0	1.0-2.5	0.03	0.02	28.0-32.0	8.0-12.0	0.5	-	0.5	-
		0.15	0.65	1.0-2.5	0.03	0.03	28.0-32.0	8.0-10.5	0.75	-	0.75	-
19 12 3 L	316L	0.03	0.65	1.0-2.5	0.03	0.02	18.0-20.0	11.0-14.0	2.5-3.0	-	0.5	-
		0.03	0.65	1.0-2.5	0.03	0.03	18.0-20.0	11.0-14.0	2.0-3.0	-	0.75	-
19 12 3 H	316H	0.04-0.08	1.0	1.0-2.5	0.03	0.02	18.0-20.0	11.0-14.0	2.0-3.0	-	0.5	-
		0.04-0.08	0.65	1.0-2.5	0.03	0.03	18.0-20.0	11.0-14.0	2.0-3.0	-	0.75	-
18 15 3 L	317L	0.03	1.0	1.0-4.0	0.03	0.02	17.0-20.0	13.0-16.0	2.5-4.0	-	0.5	-
		0.03	0.65	1.0-2.5	0.03	0.03	18.5-20.5	13.0-15.0	3.0-4.0	-	0.75	-
19 12 3 Nb	318	0.08	0.65	1.0-2.5	0.03	0.02	18.0-20.0	11.0-14.0	2.5-3.0	-	0.5	Nb=10xC to 1.0
		0.08	0.65	1.0-2.5	0.03	0.03	18.0-20.0	11.0-14.0	2.0-3.0	-	0.75	Nb=8xC to 1.0
19 9 Nb	347	0.08	0.65	1.0-2.5	0.03	0.02	19.0-21.0	9.0-11.0	0.5	-	0.5	Nb=10xC to 1.0
		0.08	0.65	1.0-2.5	0.03	0.03	19.0-21.5	9.0-11.0	0.75	-	0.75	Nb=10xC to 1.0
25 9 4 N L	385	0.03	1.0	2.5	0.03	0.02	24.0-27.0	8.0-10.5	2.5-4.5	0.2-0.3	1.5	W 1.0
20 25 5 Cu L		0.03	1.0	1.0-4.0	0.03	0.02	19.0-22.0	24.0-27.0	4.0-6.0	-	1.0-2.0	-
20 16 3 Mn L	2209	0.025	0.5	1.0-2.5	0.02	0.03	19.5-21.5	24.0-26.0	4.2-5.2	-	1.2-2.0	-
25 22 2 N L		0.03	1.0	5.0-9.0	0.03	0.02	19.0-22.0	15.0-18.0	2.5-4.5	-	0.5	-
22 9 3 N L	2594	0.03	1.0	3.5-6.5	0.03	0.02	24.0-27.0	21.0-24.0	1.5-3.0	0.1-0.2	0.5	-
		0.03	1.0	2.5	0.03	0.02	21.0-24.0	7.0-10.0	2.5-4.0	0.1-0.2	0.5	-
23 7 N L	410NiMo	0.03	0.90	0.5-2.0	0.03	0.03	21.5-23.5	7.5-9.5	2.5-3.5	0.08-0.2	0.75	-
		0.03	1.0	2.5	0.03	0.02	22.5-25.5	6.5-9.5	0.8	0.10-0.20	0.5	-
25 9 4 N L	410NiMo	0.03	1.0	2.5	0.03	0.02	24.0-27.0	8.0-10.5	2.5-4.5	0.20-0.30	1.5	W 1.0
		0.03	0.5	0.6	0.03	0.03	12.0-14.0	0.75	0.75	-	0.75	-

EN ISO 18274: welding consumables - wire and strip electrodes, wires and rods for arc welding of nickel and nickel alloys (extract)

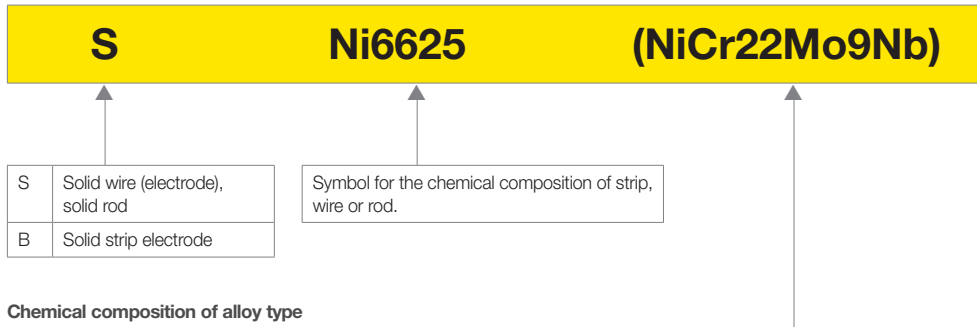

Symbol	Chemical Composition in %									
	C	Si	Mn	Cr	Ni	Mo	Nb	Cu	Fe	Other
Ni6082 (NiCr20Mn3Nb)	0.1	0.5	2.5-3.5	18.0-22.0	Min. 67.0	-	2.0-3.0	0.5	3.0	Ti: 0.7 P: 0.03
Ni6625 (NiCr22Mo9Nb)	0.1	0.5	0.5	20.0-23.0	Min. 58.0	8.0-10.0	3.2-4.1	0.5	5.0	Ti: 0.4 Al: 0.4
Ni6276 (NiCr15Mo16Fe6W4)	0.02	0.08	1.0	14.5-16.5	Min. 50.0	15.0-17.0	-	0.5	4.0-7.0	Co: 2.5 W: 3.0-4.5
Ni6059 (NiCr23Mo16)	0.01	0.1	0.5	22.0-24.0	Min. 56.0	15.0-16.5	-	0.5	2.0-5.0	Ti: 0.5 Al: 0.1-0.4

SFA/AWS A5.4: specification for stainless steel electrodes for shielded metal arc welding (extract)

E**308L**

Electrode

Nominal chemical composition of the filler metal

Symbol	Chemical Composition in %										
	C	Si	Mn	P	S	Cr	Ni	Mo	N	Cu	Other
E307	0.04-0.14	1.0	3.30-4.75	0.04	0.03	18.0-21.5	9.0-10.7	0.50-1.5	-	0.75	-
E308L	0.04	1.0	0.5-2.5	0.04	0.03	18.0-21.0	9.0-11.0	0.75	-	0.75	-
E308H	0.04-0.08	1.0	0.5-2.5	0.04	0.03	18.0-21.0	9.0-11.0	0.75	-	0.75	-
E309L	0.04	1.0	0.5-2.5	0.04	0.03	22.0-25.0	12.0-14.0	0.75	-	0.75	-
E309LMo	0.04	1.0	0.5-2.5	0.04	0.03	22.0-25.0	12.0-14.0	2.0-3.0	-	0.75	-
E310	0.08-0.20	0.75	1.0-2.5	0.03	0.03	25.0-28.0	20.0-22.5	0.75	-	0.75	-
E312	0.15	1.0	0.5-2.5	0.04	0.03	28.0-32.0	8.0-10.5	0.75	-	0.75	-
E316L	0.04	1.0	0.5-2.5	0.04	0.03	17.0-20.0	11.0-14.0	2.0-3.0	-	0.75	-
E316H	0.04-0.08	1.0	0.5-2.5	0.04	0.03	17.0-20.0	11.0-14.0	2.0-3.0	-	0.75	-
E317L	0.04	1.0	0.5-2.5	0.04	0.03	18.0-21.0	12.0-14.0	3.0-4.0	-	0.75	-
E318	0.08	1.0	0.5-2.5	0.04	0.03	17.0-20.0	11.0-14.0	2.0-3.0	-	0.75	Nb=6xCmin/1.0max
E347	0.08	1.0	0.5-2.5	0.04	0.03	18.0-21.0	9.0-11.0	0.75	-	0.75	Nb=8xCmin/1.0max
E385	0.03	0.9	1.0-2.5	0.03	0.02	19.5-21.5	24.0-26.0	4.2-5.2	-	1.2-2.0	-
E2209	0.04	1.0	0.5-2.0	0.04	0.03	21.5-23.5	8.5-10.5	2.5-3.5	0.08-0.20	0.75	-
E2594	0.04	1.0	0.5-2.0	0.04	0.03	24.0-27.0	8.0-10.5	3.5-4.5	0.20-0.30	0.75	-

SFA/AWS A5.9: bare stainless steel welding electrodes and rods (extract)

ER

316L

ER	Solid wires (electrodes or rods)
EC	Cored wires
EQ	Strip electrodes

Nominal chemical composition of the filler metal

AWS Classification	Chemical Composition in %										
	C	Si	Mn	P	S	Cr	Ni	Mo	N	Cu	Other
ER307	0.04-0.14	0.30-0.65	3.3-4.75	0.03	0.03	19.5-22.0	8.0-10.7	0.50-1.5	-	0.75	-
ER308L	0.03	0.30-0.65	1.0-2.5	0.03	0.03	19.5-22.0	9.0-11.0	0.75	-	0.75	-
ER308H	0.04-0.08	0.30-0.65	1.0-2.5	0.03	0.03	19.5-22.0	9.0-11.0	0.50	-	0.75	-
ER309L	0.03	0.30-0.65	1.0-2.5	0.03	0.03	23.0-25.0	12.0-14.0	0.75	-	0.75	-
ER309LMo	0.03	0.30-0.65	1.0-2.5	0.03	0.03	23.0-25.0	12.0-14.0	2.0-3.0	-	0.75	-
ER310	0.08-0.15	0.30-0.65	1.0-2.5	0.03	0.03	25.0-28.0	20.0-22.5	0.75	-	0.75	-
ER312	0.15	0.30-0.65	1.0-2.5	0.03	0.03	28.0-32.0	8.0-10.5	0.75	-	0.75	-
ER316L	0.03	0.30-0.65	1.0-2.5	0.03	0.03	18.0-20.0	11.0-14.0	2.0-3.0	-	0.75	-
ER316H	0.04-0.08	0.30-0.65	1.0-2.5	0.03	0.03	18.0-20.0	11.0-14.0	2.0-3.0	-	0.75	-
ER317L	0.03	0.30-0.65	1.0-2.5	0.03	0.03	18.5-20.5	13.0-15.0	3.0-4.0	-	0.75	-
ER318	0.08	0.30-0.65	1.0-2.5	0.03	0.03	18.0-20.0	11.0-14.0	2.0-3.0	-	0.75	Nb=8xCmin/1.0max
ER347	0.08	0.30-0.65	1.0-2.5	0.03	0.03	19.0-21.5	9.0-11.0	0.75	-	0.75	Nb=10xCmin/1.0max
ER385	0.025	0.50	1.0-2.5	0.02	0.03	19.5-21.5	24.0-26.0	4.2-5.2	-	1.2-2.0	-
ER2209	0.03	0.90	0.50-2.0	0.03	0.03	21.5-23.5	7.5-9.5	2.5-3.5	0.08-0.20	0.75	-
ER2594	0.03	1.0	2.5	0.03	0.02	24.0-27.0	8.0-10.5	2.5-4.5	0.20-0.30	1.5	W: 1.0
ER410NiMo	0.06	0.5	0.6	0.03	0.03	11.0-12.50	4.0-5.0	0.4-0.7	-	0.75	-

SFA/AWS A5.14: specification for nickel and nickel alloy bare welding electrodes and rods (extract)

ER

NiCrMo-13

ER	Solid wires (electrodes or rods)
EQ	Strip electrodes

Nominal chemical composition of the filler metal

AWS Classification	Chemical Composition in %										
	C	Si	Mn	P	S	Cr	Ni	Mo	Nb	Cu	Fe
ERNiCr-3	0.1	0.5	2.5-3.5	0.03	0.015	18.0-22.0	min. 67.0	-	2.0-3.0	0.5	3.0
ERNiCrMo-3	0.1	0.5	0.5	0.02	0.015	20.0-23.0	min. 58.0	8.0-10.0	3.15-4.15	0.5	5.0
ERNiCrMo-4	0.02	0.08	1.0	0.04	0.03	14.5-16.5	Bal.	15.0-17.0	-	0.5	4.0-7.0
ERNiCrMo-13	0.01	0.1	0.5	0.015	0.010	22.0-24.0	Bal.	15.0-16.5	-	0.5	1.5

Submerged Arc Welding Joint Preparations

Typical welding data and recommended joint preparations for submerged arc welding.



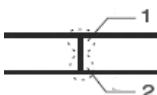
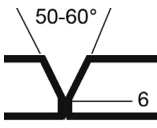
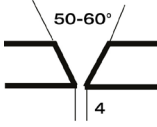



Non and low-alloyed steels

Type of joint	Plate thickness mm	Wire diameter mm	Run no	Welding current A	Arc voltage V	Welding speed cm/min	
	6	3.0	1	320	32	80	
	8	3.0	2	350	32	75	
		4.0	1	450	32		
	10	4.0	2	500	32	70	
		4.0	1	550	33		
	12	4.0	1	600	33	60	
		4.0	2	650	33		
	14	4.0	1	700	34	55	
		4.0	2	750	34		
	 <p>Gap: as small as possible; in locations where gap > 1 mm: MMA or MAG root run.</p>	For all procedures: 1 run from back side:			680	32	50
14		4.0	1	650	26	50	
		4.0	1	580	26	60	
16		4.0	2	750	34	60	
		4.0	1	580	26	60	
18		4.0	2	750	34	50	
		4.0	1	580	26	60	
20		4.0	2	750	30	60	
		4.0	3	750	34	60	
		4.0	1	580	26	60	
25		4.0	2	750	30	60	
		4.0	3	750	30	60	
		4.0	4 - 5	750	32	50	
30		4.0	1	580	26	60	
		4.0	2	750	30	60	
		4.0	3	750	30	60	
		4.0	4 - 5	750	32	50	
Alternative parameters for first run (all thicknesses):			6 - 8	750	32	50	
		4.0	1	450	25	45	
 <p>Welded from 1 side root run: MMA or MAG. Thickness of root run ≥ 5 mm.</p>		14	4.0	1	MAG or MMA	26	50
	4.0		2	550	30		
	4.0		3	600	32		
	4.0		4	680	32		
	16	4.0	1	MAG or MMA	26	50	
		4.0	2	550			32
		4.0	3	650			32
		4.0	4 - 5	680			32
	18	4.0	1	MAG or MMA	26	50	
		4.0	2	550			30
		4.0	3 - 4	650			32
		4.0	5 - 6	680			32
	20	4.0	1	MAG or MMA	26	50	
		4.0	2	550			30
		4.0	3 - 4	650			32
		4.0	5 - 6	750			32
	4.0	7	680	32	50		

Submerged Arc Welding Joint Preparations

Typical welding data and recommended joint preparations for submerged arc welding.

Non and low-alloyed steels

Type of joint	Throat thickness mm	Wire diameter mm	Run no	Welding current A	Arc voltage V	Welding speed cm/min
	3	1 x 3.0	1	500	28	80
	4	1 x 3.0	1	500	28	60
	5	1 x 4.0	1	650	30	60
	7	1 x 3.0	1	500	29	50
		1 x 3.0	2	620	32	60
	4	1 x 3.0	1	600	32	100
	5	1 x 3.0	1	600	32	60
	6	1 x 3.0	1	650	32	55
	7	1 x 3.0	1	750	32	45
	Twin Arc					
	4	2 x 1.6	1	750	32	115
	5	2 x 2.0	1	800	32	100
	Cored wire					
	5	2 x 2.4	1	800	30	120
	Tandem DC+, AC					
	4	4.0	1 (DC+)	800	32	140
	Tandem DC+, AC					
	4	4.0	1 (DC+)	800	32	140
		4.0	1 (AC)	700	36	
	5	4.0	1 (DC+)	800	32	90
		4.0	1 (AC)	700	36	

Note: If a cored wire is used, an extra 2 volts are required in the high current range (>600A) to spread the extra weld metal (25-30%).

Submerged Arc Welding Joint Preparations

Typical welding data and recommended joint preparations for submerged arc welding.

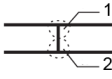
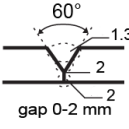
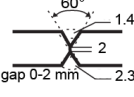
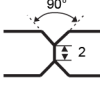
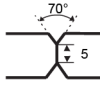
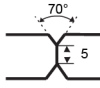

Stainless Steel

Type of joint	Plate thickness mm	Wire diameter mm	Run No.	Welding current A	Arc voltage V	Welding speed cm/min		
	6	2.4	1	300	33	40		
		2.4	2	400	34	40		
		3.2	1	400	34	100		
		3.2	2	500	34	130		
		8	2.4	1	350	33	40	
			2.4	2	450	34	40	
			3.2	1	450	34	55	
			3.2	2	550	34	55	
			4	1	450	34	100	
			4	2	550	34	130	
	10	2.4	1	420	30	45		
		2.4	2	420	32	40		
		2.4	3	420	32	40		
		3.2	1	500	30	55		
		3.2	2	500	32	55		
		4	1	550	31	65		
		4	2	550	34	100		
		12	4	1	600	32	60	
			4	2	600	34	80	
		20	4	1	575	31	60	
			4	2	600	32	60	
			4	3-5	600	34	65	
			25	4	1	550	32	60
				4	2	600	34	50
4	3			600	34	50		
4	4-8			600	34	60		
	6	2	1-n	300	31	60		
	10	3.2	1-n	380	32	65		
	16	3.2	1-n	450	34	70		
	8	4	1	450	32	90		
		4	2	550	34	85		
	10	4	1	500	32	65		
		4	2	600	34	85		
	12	4	1	500	32	60		
		4	2	600	34	70		
	14	4	1	550	32	60		
		4	2	600	34	60		

Calculation of Electrode Consumption

In the tables, joint cross section, theoretical joint volume and kg weld metal per metre length of welded joint are given. The electrode consumption per metre of welded joint is obtained by dividing the number of kg of weld metal by N, where N is the kg of weld metal per kg of electrode and is given for each electrode on their respective pages.

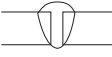
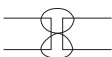
Square butt joints: joint volumes and weld metal weights

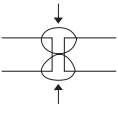
Position	Plate Thickness, mm	Gap, mm	Volume/Length, cm ³ /m	Weight/Length weld metal, kg/m
 Flat	1	0	2	0.02
	1.5	0.5	3	0.03
	2	1	4	0.03
	3	1.5	7	0.05
 Flat	4	2	17	0.13
	5	2	21	0.16
	6	2.5	27	0.21
	7	3	36	0.28
 Horizontal-Vertical	1	0	2.5	0.02
	1.5	0.5	4	0.03
	2	1	5	0.04
	3	1.5	9.5	0.07
 Horizontal-Vertical	4	2	22	0.17
	5	2	25	0.20
	6	2.5	32	0.25
	7	3	42	0.33
 Overhead	4	2	9	0.07
	5	2	10.5	0.08
	6	2.5	13	0.10
	7	3	16	0.13
	4	2	10.5	0.08
	5	2	16	0.13
	6	2.5	18	0.14
	7	3	21	0.16

Calculation of Electrode Consumption

Square V-joints: volumes and weld metal weights

Plate Thickness mm	Gap mm	50° Flat			60° Flat			70° Vertical			80° Overhead			60° Horizontal-Vertical		
		1	2	3	1	2	3	1	2	3	1	2	3	1	2	3
4	1	11.5	11	0.09	13	12.5	0.10	15	16.5	0.13	17.5	18	0.14	13	14.5	0.11
5	1	16.5	16	0.13	19.5	19	0.15	22.5	24.5	0.19	26	28	0.22	19.5	21	0.16
6	1	23	21.5	0.17	27	25.5	0.20	31	37	0.29	36	38.5	0.30	27	30	0.24
7	1.5	33.5	32.5	0.26	39	38	0.30	45	49	0.38	51.5	56	0.44	39	42	0.33
8	1.5	42	40	0.31	49	46.5	0.37	57	59.5	0.47	65.5	70	0.55	49	56	0.44
9	1.5	51	48	0.38	60.5	56	0.44	70	75.5	0.59	81.5	87.5	0.69	60.5	65	0.51
10	2	66.5	62	0.49	77.5	72	0.57	90	96.5	0.76	104	109	0.86	77.5	81	0.64
11	2	78.5	71.5	0.56	92	83.5	0.66	107	113	0.89	124	130	1.02	92	96.5	0.76
12	2	91	83	0.65	107	97.5	0.77	125	134	1.05	145	157	1.23	107	113	0.89
14	2	120	110	0.86	141	130	1.02	165	171	1.34	193	204	1.60	141	159	1.17
15	2	135	123	0.97	160	146	1.15	188	197	1.55	219	231	1.81	160	171	1.34
16	2	151	132	1.04	180	157	1.23	211	223	1.75	247	257	2.02	180	186	1.46
18	2	189	170	1.33	223	204	1.60	263	276	2.17	308	320	2.51	223	233	1.83
20	2	227	208	1.63	271	247	1.94	320	334	2.62	376	396	3.11	271	281	2.21
25	2	341	313	2.46	411	375	2.94	488	510	4.00	577	606	4.76	411	425	3.34

1 - Theoretical volume cm³/m





2 - Actual joint volume cm³/m (taking account of transverse shrinkage)

3 - Deposited weld metal kg/m





Position	Plate Thickness, mm	Weight/Length, kg/m	Electrode Diameter, mm
Flat	6-12	0.10	3.25
Flat	>2	0.15	4
Vertical	>8	0.15	3.25
Horizontal-Vertical	>8	0.15	3.25
Overhead	>10	0.10	3.25

Calculation of Electrode Consumption

Corner welds: actual joint volumes and weld metal weights

Plate Thickness	Section Size								
		cm ³ /m	kg/m	cm ³ /m	kg/m	cm ³ /m	kg/m	cm ³ /m	kg/m
2	2	3.5	0.03	3	0.02	3.5	0.03	3.5	0.03
3	4.5	7	0.05	7	0.5	7	0.05	7.5	0.06
4	8	9	0.07	9	0.07	9.5	0.07	10.5	0.08
5	12.5	13	0.10	13.5	0.11	14.5	0.11	16	0.13
6	18	18.5	0.15	19.5	0.15	21	0.16	22	0.17
7	24.5	25.5	0.20	26.5	0.21	27.5	0.22	31.5	0.25
8	32	33	0.26	34.5	0.27	36	0.28	40.5	0.32
9	40.5	41.5	0.33	43	0.34	45.5	0.36	51	0.40
10	50	51.5	0.40	53.5	0.42	56	0.44	64	0.50
11	60.5	63	0.49	67	0.53	72	0.57	78.5	0.62
12	72	74.5	0.58	79	0.62	84.5	0.66	93	0.73
15	113	116	0.91	123	0.97	132	1.04	141	1.11
18	162	167	0.31	174	1.37	190	1.49	204	1.60
20	200	206	1.62	206	1.62	227	1.78	252	1.98
22	242	248	1.95	255	2.00	275	2.16	204	2.39
25	323	329	2.58	331	2.60	370	2.90	405	3.18

Fillet welds: actual joint volumes and weld metal weights

Throat Thickness	Section Size								
		cm ³ /m	kg/m	cm ³ /m	kg/m	cm ³ /m	kg/m	cm ³ /m	kg/m
2	4	5	0.04	6	0.05	5.5	0.04	5.5	0.04
2.5	6.5	7.5	0.06	8.5	0.07	8	0.06	8.5	0.07
3	9	10.5	0.08	12.5	0.10	11	0.09	12	0.09
3.5	12.5	14	0.11	16	0.13	15	0.12	16.5	0.13
4	16	18	0.14	21	0.16	19.5	0.15	22	0.17
4.5	20.5	22.5	0.18	26	0.20	24.5	0.19	26.5	0.21
5	25	27.5	0.22	31.5	0.25	30.5	0.24	33	0.26
5.5	30.5	33.5	0.26	37	0.29	36	0.28	40.5	0.32
6	36	40	0.31	42	0.33	43	0.34	47.5	0.37
6.5	42.5	46.5	0.37	49.5	0.39	51	0.40	56	0.44
7	49	54.5	0.43	57	0.45	56	0.44	65	0.51
7.5	56.5	60.5	0.47	65	0.51	64	0.50	73.5	0.58
8	64	70	0.55	73.5	0.58	76.5	0.60	82.5	0.65
9	81	88	0.69	94	0.74	95	0.75	109	0.86
10	100	108	0.85	114	0.89	116	0.91	130	1.02
11	121	131	1.03	138	1.08	143	1.12	157	1.23
12	144	155	1.22	162	1.27	169	1.33	188	1.48
13	169	179	1.41	190	1.49	195	1.53	220	1.73
14	196	207	1.62	224	1.76	227	1.78	257	2.02
15	225	237	1.86	248	1.95	264	2.07	294	2.31

1. General

Steels are considered heat-resistant if they are characterised by good mechanical properties and high scaling resistance in the temperature range above 600°C. The steels obtain this increased resistance primarily through alloying with chromium, aluminium and/or silicon and in some cases also through alloying with rare earth metals such as cerium (Ce). Applications with the highest temperatures in air reach up to 1150°C, elements in the gas such as sulphur, chlorine, etc., decrease the permissible working temperatures significantly. Guide values for scale limit temperatures in air can be found in EN 10095.

2. Influence of Alloying Elements

Chromium (Cr)

- Improvement of scale resistance from Cr \geq 3%.

Aluminium (Al) and silicon (Si)

- Total Al + Si amounts reach up to 3%.
- Al, Si and Cr diffuse from the edge zones to the surface and are oxidised. A firmly adhering oxide layer (scale) is formed, which acts as a protective layer up to the scale limit temperature.
- Above the scale limit temperature, the diffusion rate of Al, Si and Cr is lower than that of oxygen. This penetrates into the material and reacts not only with Al, Si and Cr, but also with iron (Fe), forming a constantly growing layer of scale, which eventually peels off.

Nickel (Ni)

- Nickel (in connection with chromium) influences the microstructure:

X10CrAlSi13	ferritic structure
X15CrNiSi25-4	ferritic structure with small amounts of austenite
X8CrNiTi18-10	austenitic structure

- Nickel can reduce resistance to sulphur attack from combustion gases containing sulphur, for example. Therefore, Ni-free or low Ni, (Ni \leq 5%) steels are used in cases of sulphur attack. However, some nickel-based alloys are highly resistant to sulphur attack despite the high nickel content.

3. Classification of Heat-Resistant Steels

3.1. Ferritic Steels

Features

- Not sensitive to reducing (sulphur-containing) gases.
- Limited suitability for welding.
- Risk of embrittlement of weld metal, transition and heat-affected zone during welding.

Critical Temperature Ranges

- 400 – 500°C: Hardening leads to embrittlement (475°C embrittlement). This can be eliminated by annealing briefly above 600°C.
- 650 – 800°C: Formation of the brittle sigma phase. This can be dissolved again by annealing above 850°C.
- 950°C and higher: Strong grain growth and carbide precipitation at the grain boundaries. Removal is not possible.

Welding-Related Processing

- Careful joint preparation.
- Tack at short intervals (observe welding sequence!).
- Preheating prior to welding, usually 200°C.
- As low heat input as possible during welding, interpass temperature max. 300°C.
- When welding larger joint cross-sections, use austenitic consumables for the filling runs.
- Subsequent tempering for stress relief.

3.2. Ferritic-Austenitic Steels

- The resistance to gases containing sulphur is higher than that of austenitic steels, since steels with Ni \leq 5% are relatively insensitive to sulphur attack.
- Better weldability than purely ferritic steels.

Welding-Related Processing

- Ferritic-austenitic steels require precision heat management.
- In case of sulphur attack, select identical/similar welding consumables (Ni \leq 5%).
- Metal thicknesses $s \geq$ 12 mm should be preheated to 100 – 150°C when welding with low heat input. The interpass temperature should not exceed 250°C.

3.3. Austenitic Steels

Features

- Sensitive to sulphur-containing gases, this also applies to austenitic weld metal.
- Good resistance to carburizing and nitrogen-containing furnace atmosphere.
- Good workability at room temperature.
- Good weldability.

Critical Temperature Ranges

- 500 – 850°C: Formation of the brittle Sigma phase. This can be dissolved again by annealing above 1050°C.

Welding-Related Processing

- No preheating.
- Low heat input during welding, max 15 kJ/cm.
- Low interpass temperature, max. 150°C, for fully austenitic steels such as 1.4821.
- When welding the same type of alloy 25Cr/20Ni, the weld metal solidifies fully austenitic and is more susceptible to hot cracking. Therefore, aim for the lowest possible heat input when welding using string beads, do not use weaving.
- Interpass temperature max. 150°C.

4. Approvals and Qualification Tests

Many heat-resistant materials are used in non-pressurised systems such as heating and exhaust systems. Approval and suitability testing by technical certification authorities for the parent materials and welding consumables is therefore not usually required.

1. General

According to their alloy composition, these materials are categorised as alloyed structural steels. To improve weather resistance, elements such as these are added:

■ Copper (Cu)	0.25 to 0.55%
■ Chromium (Cr)	0.3 to 1.25%
■ Nickel (Ni)	Up to 0.65%
■ Molybdenum (Mo)	up to 0.30%
■ Zirconium (Zr)	up to 0.15%

These form protective layers on the surface, which are constantly renewed with exposure to weather or weathering. This protects the surface and significantly slows down the corrosion process. Materials 1.8945 and 1.8946 contain phosphorus $P \leq 0.16\%$, which may impair weldability.

Weather-resistant structural steels are mostly used in heavily weathered applications, e.g.:

- Bridges, road barriers, parking garage structures, facades, stadiums, crane systems,
- Railway carriages, tram and subway cars, agricultural machinery and road vehicles,
- Radio and lighting masts, steel chimneys, exhaust pipes, pipelines, etc.

They can be used with or without a colour coating. Without subsequent colouring, the surface forms a decorative reddish rust layer. This effect is also used for aesthetic reasons for bridges, facades, design constructions and sculptures.

Weather-resistant structural steels are offered under various brand names, for example

- Allwesta 360 / Allwesta 510,
- COR-TEN A / COR-TEN B,
- DIWETEN 355-M / DIWETEN 460-M,
- Patinax,
- Alcodur,
- Coraldur, etc.

2. Welding of Weather-Resistant Structural Steels

Weather-resistant steels can be welded, but when selecting the welding filler material, it is important to ensure that the weld metal is also weather-resistant. Similar welding filler metals are therefore also alloyed with CuNi(Cr). In multi-run welding, it is often adequate to weld only the upper covering layers exposed to the atmosphere or the bottom passes of the side exposed to weathering with the supplement of the same type. EN 1090-2 and the European Design Guide specify the following types of welding consumables as suitable for weathering structural steels:

	Option 1	Option 2	Option 3
Weld metal type	Ni1Cu (similar type)	2Ni/Ni2	Ni1Mo

Special note: when welding weather-resistant steels, fine cracking may occur in the heat-affected zone. These are hot cracks caused by a low-melting copper-iron compound on the surface of the parent material. Prior to welding, the covering layer that forms should therefore be removed by grinding, for example, at a width of 10 to 20 mm from the edge zones being welded. According to ZTV-ING - Part 4, Section 1, Paragraph 8, welding consumables with a CE declaration of performance in accordance with the Construction Products Regulation and an approval certificate in accordance with EN 14532-1 (e.g. DB approval) are required for use in bridge construction.

Further information on selecting and processing weather-resistant structural steels can be found in the following:

EN 1090-2: Execution of steel and aluminium structures - Part 2: Technical rules for the execution of steel structures

EN 10025-5: Hot rolled products of structural steels – Part 5: Technical delivery conditions for weathering structural steels

ECCS AC3 Bridge Committee: European design guide for the use of weathering steel in bridge construction. 2nd Edition, 2021.

1. Materials

This section contains welding consumables for high strength steels with yield strengths \geq 485 MPa. For lower yield strengths see Section B.

2. Welding and Heat Treatment

2.1 General

So-called high-strength steel grades are generally considered to be easy to weld. In general, however, as the minimum yield strength and sheet thickness increase, greater care must be taken during processing. When welding begins, the weld joints must be dry and free of cutting slag, rust, scale and contaminants. In the interest of cold cracking resistance, welding consumables should be used that result in a low hydrogen content in the weld metal. High-quality basic stick electrodes and flux meet this requirement.

These should be stored in a dry place and, if necessary, dried again before use. Using welding consumables from vacuum packaging (e.g. stick electrodes: VacPac™, welding flux: BlockPac™) can eliminate these time and cost expenditures. Modern metal flux, rutile and basic-cored wires also ensure a very low hydrogen content and do not require re-baking. TIG rods and solid wires for MAG welding produce weld metal with a very low hydrogen content due to the manufacturing process.

2.2 Preheating, Interpass Temperature and Post-Weld Heat Treatment

The preheating must be selected with consideration for the carbon equivalent, metal thickness, heat-dissipating cross-section and heat input. Preheating is primarily used to avoid brittle hardening zones in the HAZ. Any special requirements regarding the toughness of the heat-affected zone are not taken into consideration here.

For high demands for cold resistance, even at relatively low material thicknesses (from approx. 12 mm) preheating to approx. 80 - 150°C is recommended. In many standards and programs, the minimum preheating temperature is defined to avoid cold cracking, which, however, does not guarantee sufficient toughness of the heat-affected zone (HAZ). On the other hand, maintaining the maximum interpass temperature serves to prevent grain growth in the HAZ. Coarse grain formation is associated with a decrease in toughness and a slight increase in hardness.

The interpass temperature is usually at least 50°C above the preheating temperature, but max. 250°C. Very low heat input (e.g. short, thin tacks on thick sheets without preheating) leads to abrupt cooling and thus hardening or the risk of cracking. If welding is "too hot" (e.g. very wide weave beads welded in the vertically up position), this can lead to coarse grain formation and a decrease in strength and toughness.

For the steels listed below, stress relieving is usually the only heat treatment that can be considered. Before a welding consumable is selected, the resulting impact on the weld metal properties (decrease in strength and toughness, if applicable) must be taken into consideration.

2.3 Notes on Welding

- Welding consumables whose strength is not significantly higher than the parent material should be selected.
 - Tack and root welding is often performed with “softer” welding consumables to avoid cracking, e.g. TIG root welding with OK Tigrod 13.28, OK Tigrod 13.09 or OK Tigrod 55.
 - If there is an increased risk of cold cracking, a hydrogen-reducing annealing (“soaking”) at 200 - 280°C / >2h is recommended after welding.
 - Preheating and heat input during welding must be selected according to the recommendations of the steel manufacturers.
 - If higher fracture toughness properties are required, then multi-pass welding should be used.
 - The weld build-up should be started at the weld edges; the subsequent bead has a positive effect on the heat-affected zone.
 - Smaller electrode diameters must be used when welding vertical seams.
 - For material thicknesses >12 mm, tack welding must always be carried out with preheating.
 - The length of a bead (tack) should not be less than 50 mm.
- If tack welds form part of the weld joint, the welding consumables used must be adapted to the parent material. The tacks must be checked for cracks before being welded over.
 - The arc must be ignited on the component in the weld groove.
 - The same instructions apply to repair welding as for welding in production.
 - Non-destructive testing should be carried out at least 24 hours after completion of the welding work, as cold cracking may appear after a delay.
 - **For further information, refer to:**
 - Steel-Iron Material Data Sheet SEW 088: Weldable fine-grain steels and SEW 088 supplements, SEW 063, SEW 086, SEW 090
 - EN 1011: Welding – Recommendations for welding of metallic materials
 - Part 1: General instructions for arc welding
 - Part 2: Arc welding of ferritic steels

1. General

Cold resistance is the suitability of materials for use at low temperatures. For steel materials, this generally means evidence of sufficient impact toughness down to -60°C and below.

Low-temperature steels are increasingly used for gas liquefaction plants and for the transport and storage of liquid gases. Essentially, these steels can be classified as follows:

- Unalloyed and low-alloyed low-temperature steels
- Nickel steels with 1.5 to 3.5% Ni (down to -105°C)
- Nickel steels with 5 to 9% Ni (below -100°C to -196°C)
- Austenitic CrNi and CrNiMo steels

2. Welding of Cryogenic Nickel Steels

For Ni steels up to approx. 3% Ni, a filler material of the same type can be used. With higher nickel contents, a filler material of the same type cannot be used due to the risk of hot cracking. Instead, over-alloyed austenitic or nickel-based welding consumables are used. If austenitic welding is used, fatiguing of the joint can be expected under thermal cycling stresses due to the stresses that occur due to different melting points of the alloys (different thermal expansion coefficients). Particular attention must be paid to the strength values and 0.2% yield strength of the weld metal on the joint as this is a mixture of the filler metal and the base metal. No post-heat treatment is permitted, as carbon diffusion into the austenite has a negative effect on the impact toughness at low temperatures.

5 - 9 % Nickel Steel

After heat treatment, the 5 - 9% Ni steel has a structure consisting predominantly of low-carbon, soft, tempered martensite. No preheating is used during welding so that the dwell times at higher temperatures are kept as short as possible and undesirable austenite formation does not occur. In addition, smaller diameters and the stringer bead technique are preferred. The maximum interpass temperature should be limited to 150°C. Heat inputs of 6 – 20 kJ/cm are common. Problems can arise when welding higher alloyed Ni steels due to the influence of residual

magnetism, which creates a magnetic arc blow effect that causes a strong deflection of the arc and prevents proper welding. When welding with a direct current, the cables carrying the current can also create a magnetising effect. 5% Ni steels such as X12Ni5 and 9% Ni steels such as X8Ni9 tend to develop permanent magnetism.

Measures:

- Demagnetise sheets to a field strength of less than 1.6 kA/m, max. 4.8 kA/m at the joint edges
- Welding with an alternating current
- Use the TIG process
- Attaching opposite poles or permanent magnets

4. Welding Of Cold-Resistant CrNi and CrNiMo Steels

These steels are also known as stainless steels (see also Section H). They are welded with unstabilised or stabilised welding consumables of the same type. The unstabilized weld metal is slightly superior to the stabilised one in terms of low-temperature toughness. Unstabilised CrNi steels without molybdenum, especially CrNiN grades, are the preferred choice and must be welded with the same type. For the transport and storage of liquefied gases such as hydrogen (-253°C) or helium (-269°C), the use of steels with higher nickel and molybdenum content has become an established practice; standard grades such as 1.4404 X2CrNiMo17-12-2 or AISI 316L are usually used. Exaton 19.12.3.L CRYO is developed as a similar, (to 316L) welding filler. Checking the low-temperature toughness is a problem in quality assurance, since impact bending tests at -269°C are very complex and costly. Relevant standards have therefore introduced testing at -196°C subject to safety allowances with regard to the required impact energy and the lateral expansion of the impact bending specimens. For cryogenic systems used for operating temperatures colder than -196°C, the parent material, the HAZ of the weld and the weld metal must be tested at -196°C (see Table 1). For the parent material, a test certificate 3.1 is usually required for batch-related testing ("pre-use test") of the pure weld metal.

Table 1:

Typical requirements based on EN 21028-1 and ASME Sec. VIII, Div. 1, UHA-51 (extract) on the resistance of joints on austenitic steels and the filler material at temperatures lower than -196°C:

Requirements for impact toughness at -196°C			
Impact bending specimens	Test temperature	Charpy V-Notch Properties	Lateral expansion
Parent material, HAZ, weld metal	-196°C	min. 40 J/cm ²	min. 0.53 mm
Deposited metal of the welding material used ("pre-use test") for each batch/lot	-196°C	min. 40 J/cm ²	min. 0.53 mm

Further information on welding of cryogenic steels and the requirements for cryogenic systems can be found in:

- EN ISO 21028-1:
Cryogenic vessels - Toughness requirements for materials at cryogenic temperature - Part 1: Temperatures below -80°C.
- ASME Section VIII, Division 1, UHA-51: Impact Test.

1. Heat-Resistant Ferritic Steels

Operating temperatures and pressures have been continuously increasing in recent decades to improve the efficiency of plants in the energy and heat generation industries. However, only heat-resistant and high heat-resistant steels can withstand temperatures of around 500°C and higher and meet the additional requirement of scale resistance. While the strength values of unalloyed structural steels drop considerably at elevated operating temperatures, the hot strength properties are significantly improved by alloying with chromium, molybdenum, vanadium and tungsten. Alloying measures are used to counteract the creep processes that occur in steels placed under increased temperatures and stresses. Since these processes are time-dependent, it is insufficient to consider only the mechanical properties from the accelerated test to determine whether a steel can be used. Rather, the creep rupture strength must be used for the evaluation. The creep rupture strength values of heat-resistant steels are specified in standards and material data sheets.

2. Creep Resistant Steels

In the chemical industry, processes are used in which hydrogen occurs under high pressure and high temperatures. After being alloyed and heat treated, the materials used in these plants must have sufficient heat resistance and resilience to withstand exposure to hydrogen. This additional requirement has emerged because high-pressure hydrogen penetrates the unalloyed steel at an atomic level and breaks it down at temperatures above approx. 200°C decarburizes, loosens the structure and reduces the strength. In order to improve their behaviour towards pressurised hydrogen, the steels usually contain up to 6% chromium as a carbide former, as well as molybdenum to increase heat resistance and prevent temper embrittlement. Some of these steels even contain vanadium as an additional carbide former. The steels obtain their strength characteristics through hardening heat treatment.

3. Operating Temperatures of Typical Creep Resistant Steels

Non-alloyed and Mn-alloyed boiler and tube steels	P235GH P355GH	Up to 500°C
Heat-resistant special steels	15NiCuMoNb5-6-4 (WB 36) 17MnMoV6-ww4 (WB 35) 20MnMoN4-5	Up to 550°C
Mo-alloyed steel	16Mo3	Up to 530°C
CrMo-alloyed steels	13CrMo4-5 10CrMo9-10 X12CrMo5	Up to 570°C Up to 600°C Up to 625°C
CrMoVNb-alloyed steel	X10CrMoVNb 9-1	Up to 650°C

At temperatures above 600°C, austenitic chromium-nickel steels, e.g. type 16/13, are also used. If the operating temperature rises above 700°C, only special alloys based on Ni/Cr/Co have sufficient heat resistance characteristics.

4. Welding and Heat Treatment

Low-alloy, creep resistant steels are generally welded in a tempered condition, while steel grade 16Mo3 is welded in a normal annealed condition. These steels are air-hardening, which means that when the steel cools down from the heat of welding, it hardens in the heat-affected zone. In combination with residual welding stresses, any necessary straightening work and the operating load make these steels susceptible to cracking. Effective heat management must therefore be guaranteed during welding. In particular, the preheating temperature (see EN 1011-2), interpass temperature, post-weld heat treatment as well as suitable weld bead shape and weld sequence must be observed.

Alloy type of the welding material	Preheating and interpass temperature (°C)	Post-weld heat treatment	
		Annealing temperature (°C)	Hold time (h)
Mo, MoL	< 250	570 – 620	> 0.5
CrMo1, CrMo1L	200 – 300	660 – 700	> 0.5
CrMo2, CrMo2L	200 – 350	690 – 750	> 0.5
CrMo5	300 – 350	730 – 760	> 1
CrMo91	200 – 300	750 – 770	> 2

5. Welding Consumables, Suggestions for Heat-Resistant Material Pairings:

Alloy type of the welding material		Parent material 2					
		16Mo3 (T/P1) G18Mo5 G20Mo5	13CrMo4-5 (T/P11) 13CrMoSi5-5 G17CrMo5-5 25CrMo4	10CrMo9-10 (T/P22) 11CrMo9-10 12CrMo9-10 G17CrMo9-10	X11CrMo5 (T/P5) X12CrMo5 X16CrMo5-1 GX15CrMo5	X11CrMo9-1 (T/P9) GX12CrMo10-1	X10CrMoVNb9-1 (T/P91)
Parent material 1	Unalloyed steels, Sections B and F, e.g. S235JR, P355GH, and similar.	type Mo, MoL (Section B)	type Mo, MoL	-	-	-	-
	16Mo3 (T/P1) G18Mo5 G20Mo5	type Mo, MoL	type Mo, MoL	type Mo, MoL	type CrMo1, CrMo1L	type CrMo2, CrMo2L	type CrMo2, CrMo2L
	13CrMo4-5 (T/P11) 13CrMoSi5-5 G17CrMo5-5 25CrMo4	type Mo, MoL	type CrMo1, CrMo1L	type CrMo1, CrMo1L	type CrMo2, CrMo2L	type CrMo2, CrMo2L	type CrMo2, CrMo2L
	10CrMo9-10 (T/P22) 11CrMo9-10 12CrMo9-10 G17CrMo9-10	type Mo, MoL	type CrMo1, CrMo1L	type CrMo2, CrMo2L	type CrMo2, CrMo2L	type CrMo5	type CrMo5
	X11CrMo5 (T/P5) X12CrMo5 X16CrMo5-1 GX15CrMo5	type CrMo1, CrMo1L	type CrMo2, CrMo2L	type CrMo2, CrMo2L	type CrMo5	type CrMo5	type CrMo5
	X11CrMo9-1 (T/P9) GX12CrMo10-1	type CrMo2, CrMo2L	type CrMo2, CrMo2L	type CrMo5	type CrMo5	type CrMo9, CrMo91	type CrMo91
	X10CrMoVNb9-1 (T/P91)	type CrMo2, CrMo2L	type CrMo2, CrMo2L	type CrMo5	type CrMo5	type CrMo91	type CrMo91

The type and method for implementing the post-weld heat treatment as well as weld joint requirements must be taken into consideration when selecting the welding consumable. ESAB technical consultants are available to answer any questions you may have.

6. References

- EN 1011: Welding – Recommendations for welding of metallic materials –
Part 1: General instructions for arc welding
Part 2: Arc welding of ferritic steels
- EN 10028-2: Flat products made of steels for pressure vessels –
Part 2: Unalloyed and alloy steels with specified elevated temperature properties.
Contains information on post-weld heat treatment and testing by step cooling ("step cooling test").
- EN 10213-1: Technical delivery conditions for steel castings for pressure vessels –
Part 1: General, Annex A: Welding conditions.
Contains recommendations for the preheating temperature, maximum interpass temperature and post-weld heat treatment, informative for cast steel grades according to EN 10213-2: Steel grades for use at room temperature and at elevated temperature.

1. Cast Iron with Lamellar Graphite (GJL / GG)

Broken cast parts made of cast iron with lamellar graphite (grey cast iron) are often repaired by welding. Usually, different welding consumables are used with little or no preheating. In this case, structural changes in the heat-affected zone and high residual stresses must be taken into consideration. Appropriate precautions must therefore be taken to prevent cracking. Where possible, heat input must be minimised by selecting small electrode diameters with a low welding current for the stringer bead technique. The beads are offset against one another. It is common to weld very short beads (20 - 30 mm), which are then stretched by hammering before cooling to reduce the residual welding stress. The weld area should not become warmer than hand-hot if possible; if necessary, welding work should be interrupted for intermediate cooling.

2. Spheroidal Graphite Cast Iron (GJS / GGG)

Welds on ferritic grades can be carried out with different welding consumables without preheating, but castings sensitive to stress can be pre-heated to 100 - 250°C and complicated shapes to approx. 400°C. In general, electrodes that are as thin as possible are processed with a short arc and low currents. Short, thin stringer beads (20 - 30 mm) are chipped off. Allow to cool between layers and change welding direction.

3. Malleable Cast Iron (GJM / GT)

3.1. Black Malleable Cast Iron (GJMB / GTS)

In order to avoid the formation of hardening structures in the heat-affected zone, the heat input must be as low as possible, since GJMB (GTS) contains between 0.4 and 0.7% C. The mechanical-technological properties and the mechanical workability of the weld area can be improved by post-weld heat treatment, e.g. annealing.

3.2. White Malleable Cast Iron (GJMW / GTW)

GJMW (GTW) is decarburised and therefore contains a higher ferrite content and barely any tempered carbon in the edge zones and if the metal is not very thick ($s \leq 15$ mm). The heat-affected zone is therefore less susceptible to hardening. If hardening occurs due to the position of the welding point, this can also be eliminated by annealing. GJMW-360-12W has a better weldability due to certain chemical adjustments and extensive decarburisation. This grade is therefore preferable for parts intended for welding and can be welded up to 8 mm wall thickness without preheating. Many of the welding consumables listed in Section B are suitable for heavily decarburised seam areas. For welding on slightly decarburised areas, welding fillers with nickel content should be given preference.

4. Heterogeneous Joints Between Cast Iron and Steel

Due to the decarburised surface layer of GJMW, joints with steel can be made using low-alloy basic MMA electrodes and flux-cored wires. For other types of cast iron with high carbon contents, Ni and NiFe welding consumables can be used preferentially. Basically, the dilution from the cast iron side should be kept to a minimum.

5. Repair of Cracks in Castings

When repairing cracks, the crack is first located, usually using dye penetrant testing. The points where the crack ends must be drilled out and the crack can then be removed with the gouging electrode OK GPC. After grinding, welding is carried out from the centre of the crack towards the ends of the crack.

Further information includes:

- EN 1011-8:
Welding - Recommendations for welding metallic materials – Part 8: Welding of cast iron

1. General

In many constructions, a wide variety of materials are used for cost reasons, but predominantly for reasons relating to mechanical and chemical stress. It is therefore often necessary to weld joints between these materials. When welding different types of steel, certain standards must be met to ensure that the weld can withstand the conditions it will be exposed to during operation. The section below contains information on choosing a suitable welding consumable and on dilution problems for a selection of different types of important joint configuration.

2. Basics

Joining together two different parent materials (e.g. a low-alloy ferritic and a high-alloy austenitic parent material) creates a heterogeneous weld metal. The degree of dilution between the weld metal and the molten parent material essentially depends on the welding procedure and the selected welding parameters.

2.1 Influence of the Welding Procedure on the Degree of Dilution

Welding Process	Degree of Dilution/Pick-Up
SAW strip	15 – 25 %
ESW strip	5 – 15 %
SAW wire	40 – 50 %
SMAW	15 – 30 %
MIG/MAG	25 – 40 %
TIG with filler material	20 – 40 %
TIG without filler material	100 %

2.2 Influence of Welding Parameters on the Degree of Dilution

The large ranges in the degree of dilution of the various welding procedures are a direct result of the parameter ranges. In general, dilution with the parent material should be minimised wherever possible. This means keeping the heat input low by optimising the welding parameters. This can be achieved by:

- Low current
- Welding in stitch beads, no weaving
- Use of small electrode diameters
- Highest possible welding speeds
- Possible intermediate cooling

In addition, it should be noted that the arc should not burn on the ferritic parent material but on the already melted weld metal.

2.3 Technical Welding Information

2.3.1 Austenite-Ferrite Joints

When using austenitic welding consumables:

- Use low-dilution welding processes
- With alloy type 18 8 mn there is no risk of hot cracking due to the increased mn content
- No post-weld heat treatment and use in operation up to a maximum of 300°C (at higher temperatures chromium carbides precipitate at the grain boundaries and deplete the grains of chromium, which reduces the strength and the corrosion resistance!)

When using Ni-based alloys:

- Pay particular attention to low dilution
- also suitable for operating temperatures above 300°C
- Also suitable for post-weld heat treatment, usual procedure = separate design:
 - Buffer the fusion face of the low-alloy parent material with Ni-based alloy
 - Carrying out the necessary post-weld heat treatment, e.g. tempering or stress relieving
 - Welding the joint between the Ni-based buffer layer and the high-alloy welding material with nickel-based filler metal

3. Determine the Microstructure Using Schaeffler Diagram

In most cases, the Schaeffler diagram can be used with sufficient accuracy to describe the developing microstructure. The general idea behind selecting filler metals is to shift use of the resulting weld metal composition to less hazardous areas. The area containing martensite should be avoided as this is where embrittlement occurs, leading to cracking. However, the choice of filler materials is further restricted by the fact that the resulting weld metal should not

be located in the fully austenitic area, because purely austenitic phase formation poses a risk of hot cracking during solidification. If the resulting weld metal alloy is located too far to the right in the Schaeffler diagram, sigma phase will form, particularly during subsequent use at elevated temperatures, which is very brittle and may also threaten the integrity of the weld. There remains a relatively small area in the middle of the diagram.

When working with the Schaeffler diagram, its validity limits for the alloy content must be noted:

C < 0.2%	Si < 1%	Mn < 4.0%	Mo < 3%	Nb < 1.0%
----------	---------	-----------	---------	-----------

Example:

At approximately 6 % Mn, the welding consumables of type 18 8 Mn are outside the validity range. In the Schaeffler diagram, the position of the weld metal is therefore within the hot cracking danger area, although the high Mn content provides very good resistance to hot cracking. In fact, the weld metal also contains delta ferrite, even though a fully austenitic weld metal would be expected according to Schaeffler. Exceeding the validity limits for the alloy proportions would therefore render the result in the Schaeffler diagram unusable.

3.1. Welding an austenite-ferrite joint (example)

Chemical composition of the materials:

No.	Material	W.-Nr.	Reference analysis (%)						equivalents	
			C	Si	Mn	Cr	Ni	Mo	Cr _A	Ni _A
1	Ferritic parent material P355GH	1.0473	0,20	0,5	1,2	-	-	-	0,75	6,6
2	Austenitic parent material X15CrNiSi25-21	1.4841	0,15	2,0	1,6	25	21	-	28,0	26,3
3	Selected filler material, alloy type: 23 12 L / 309L MMA electrode OK 67.60	1.4332	0,02	0,8	0,8	24	13	-	25,2	14,0

The points resulting from the nickel and chromium equivalents for parent materials 1 and 2 are entered into the Schaeffler diagram with a line drawn between them. If it is assumed that both parent materials are melted in equal parts, then the middle of the straight line corresponds to the microstructure of the heterogeneous parent material (point A).

From the position of this point, it can also be deduced that TIG welding without filler material is not suitable, for example. The microstructural point 3 of the filler material is also drawn in the diagram and subsequently connected to point A of the heterogeneous parent material. I

f the length of the line is set to 100% and the dilution percentage for the welding procedure

used is subtracted from the welding filler side (MMA electrode OK 67.60 = approx. 25%), point B is produced for the microstructure = heterogeneous weld metal. In multi-layer welding, the microstructure of the previously welded layer would have to be taken into consideration as a third parent material component to determine the structure more precisely.

In general, however, it is sufficient to shift the structure points of the following layers along the straight line to the filler material side. For the above-mentioned, for example, the operating temperature of the component must also be taken into account; for OK 67.60, 300°C should not be exceeded.

At higher operating temperatures, nickel-based welding consumables are preferable, e.g. OK NiCrFe-3. However, the position of the filler material outside the Schaeffler diagram cannot be calculated.

3.2 Cladding a Ferritic Parent Material (Example: Buffer Layer)

Parent material:	P355GH
Cladding material:	alloy type 23 12 L / 309L, e.g. MMA electrode OK 67.60
Degree of mixing:	25%
Analysis type - chromium and nickel equivalent	see section 3.1.

First, the structure points of the parent material (point 1) and the filler material (point 3) are entered into the diagram. The points are connected. The length of this line is 100%. From the filler metal side (point 3), the degree of dilution is marked off at 25% and the heterogeneous weld metal is obtained (point C).

1. Computational microstructure determination

Although the position of the Schaeffler diagram can be used to determine the chromium and nickel equivalents, the individual alloy components cannot be determined from this. This can be done very precisely by calculation.

The computational determination must be carried out using the example of cladding (section 3.2), equations:

- 1) Dilution factor F_v = dilution percentages: 100
- 2) $F_v \times$ alloying components of the parent material + $(1 - F_v) \times$ alloying components of the welding filler metal = alloying components of the mixed weld metal Result calculation:

Material	Dilution Factor	Reference Analysis (%)					Equivalents	
		C	Si	Mn	Cr	Ni	Cr _A	Ni _A
Ferritic parent material P355GH	-	0,20	0,5	1,2	-	-	0,75	6,6
Alloy type: 23 12 L / 309L MMA electrode OK 67.60 (deposited metal)	-	0,02	0,8	0,8	24	13	25,2	14,0
P355GH Share of weld metal: 25%	0,25	0,05	0,13	0,3	-	-		
OK 67.60 Weld metal proportion: 75%	0,75 (1 - 0,25)	0,02	0,60	0,6	18	9,8		
Heterogeneous weld metal of the cladding		0,07	0,73	0,9	18	9,8	19,1	12,4

The result is a heterogeneous weld metal in the form of cladding, which is comparable to a stainless steel, e.g. 1.4301 X5CrNi18-10. Of course, this intermediate layer can be followed by further cladding layers with suitable welding consumables.

Further information on welding dissimilar joints of different types of steels and claddings:

- EN 1011-5:
Welding - Recommendations for welding metallic materials, Part 5: Welding clad steels
- EN ISO 9692-4:
Recommendations for joint preparation, Part 4: Clad steels



Schaeffler Diagram

- | | | | | |
|--------------------|---------------------|------------------|----------------|-------------|
| 1: X15CrNiSi25-21 | 4: X2CrNiMo18-14-3 | 7: X2CrNi19-11 | 10: P235GH | 13: X12Cr13 |
| 2: X5CrNiMo17-12-2 | 5: X10CrNiMoNb18-12 | 8: X6CrNiNb18-10 | 11: 16Mo3 | 14: X6Cr17 |
| 3: X15CrNiSi20-12 | 6: X5CrNi18-10 | 9: 13CrMo4-5 | 12: 10CrMo9-10 | 15: P355GH |

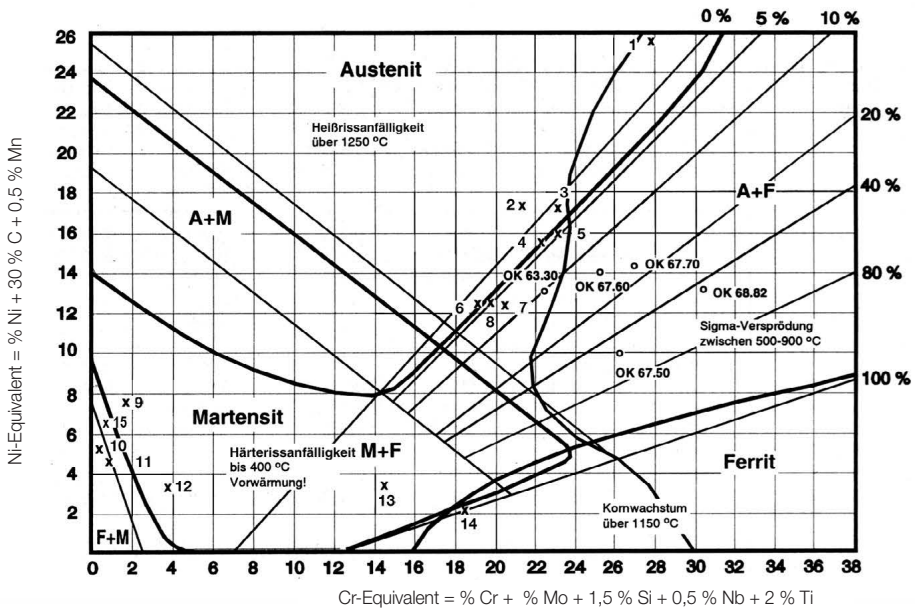
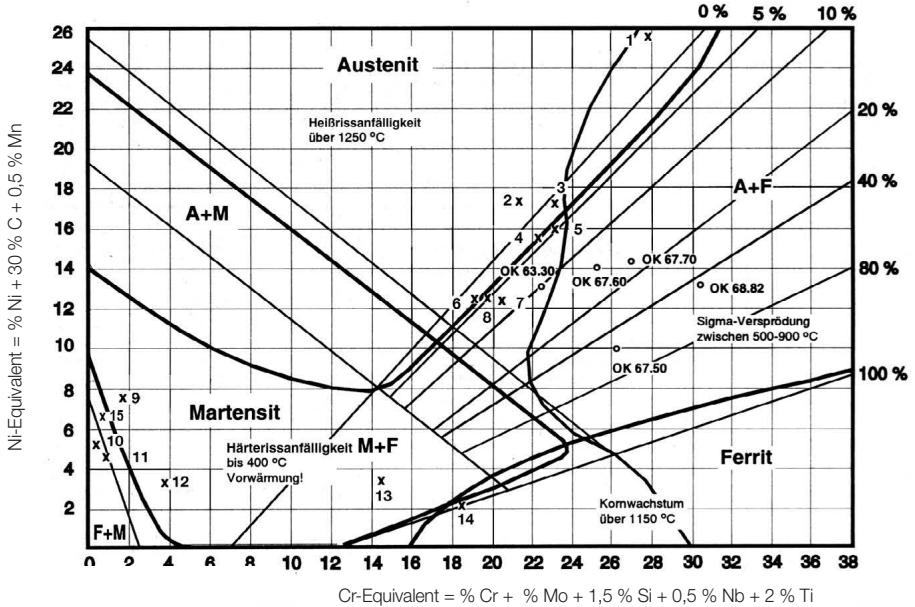

1. General

Duplex steels contain a structure consisting of approximately equal parts of ferrite and austenite (usually 45 – 60%). Ferrite provides increased strength values and resistance to stress corrosion cracking, while austenite is responsible for good toughness and general corrosion resistance.

This microstructure combination combines improved mechanical properties with excellent corrosion resistance. Due to the increased yield strength compared to CrNi standard austenites, material usage can be reduced by decreasing the metal thickness. Furthermore, the ferritic-austenitic duplex steels have improved corrosion resistance against pitting, crevice and stress corrosion cracking compared to CrNi or CrNiMo austenites. The main grade of duplex steels is currently **X2CrNiMoN22-5-3**, which has a wide range of applications in the form of rolled, forged, and cast products.

The calculation of the PRE (Pitting Resistance Equivalent) using the composition of the alloy, is used to classify between duplex, super-duplex and hyper-duplex steels. The calculation indicates the resistance to pitting corrosion of the alloy, and is determined for duplex, super-duplex and hyper-duplex steels as follows:

PRE = %Cr + 3.3 %Mo + 16 %N	(in percentage by weight)	
PRE < 40	Duplex Steel	e.g.: X2CrNiMoN22-5-3: PRE = 35
PRE < 40	Lean-Duplex Steel	e.g.: X2CrNiN23-4: PRE = 26
PRE ≥ 40	Super-Duplex Steel	e.g.: X2CrNiMoN25-7-4: PRE = 42
PRE ≥ 48	Hyper-Duplex Steel	e.g.: X2CrNiMoCoN28-8-5-1: PRE = 48

2. Welding

It is generally assumed that duplex stainless steels should be treated in the same way as austenitic steels for welding purposes. However, practical experience has shown that this is not the case. Therefore, here is some useful information:

In order to achieve a match in mechanical properties and corrosion resistance between the weld metal, heat-affected zone and parent material, the analysis of the filler metal and temperature control must be taken into consideration. At high cooling rates, which austenites require, a microstructure with an excessively high ferrite content may be produced, which does not have sufficient corrosion resistance and toughness. On the other hand, if the cooling rate is too low, phase precipitation and embrittlement can be expected; stringer beads with no weaving should be used in order to minimise the heat input.

Cooling Time:

- Favourable cooling times are within the range $t_{12/8} = 8 - 10$ s.

Heat Input:

- The range of recommended heat input is generally $E_s = 5 - 25$ kJ/cm for duplex steels,
- For lean duplex steels, $E_s = 2 - 15$ kJ/cm mostly applies,
- For super and hyper-duplex steels, $E_s = 2 - 15$ kJ/cm applies, but for thin sheets, $E_s \leq 10$ kJ/cm is preferred.

Preheating:

- Preheating is usually not necessary.
- However, unlike austenitic steels, preheating to $T_v = 100^\circ\text{C}$ may be advisable when welding duplex steels with thicknesses above $s = 12$ mm with a very low heat input or when performing short tack welds.
- Modern duplex steels with a nitrogen content of $N \geq 0.15\%$ as well as lean and super duplex steels do not usually require preheating if the correct heat input is maintained.

Interpass Temperature:

- The interpass temperature for duplex should not exceed $T_z = 250^\circ\text{C}$, for lean and super duplex should not exceed $T_z = 150^\circ\text{C}$ and for hyper duplex should not exceed $T_z = 100^\circ\text{C}$.

Joint Preparation:

- The prepared joint and the adjacent area should be thoroughly cleaned. In general, only tools and wire brushes designed for stainless steel should be used. To avoid a lack of fusion and allow the weld pool to flow into the joint, wider joint angles have been introduced for butt welds ($70 - 80^\circ$).

Shielding Gas:

- Pure nitrogen is usually recommended for backing gas.

Arc Ignition:

- In order to avoid creating corrosion points, the arc must not be ignited in an area that will not be welded over at a later time.

Execution:

- Due to the risk of cracking and insufficient microstructure formation, welding without filler material should generally be avoided. It is important to ensure a sufficient supply of filler material, especially with manual TIG welding.

Rework:

- Thorough cleaning of the joint is a prerequisite for good corrosion resistance. Slag and oxides must be completely removed before passivation. In order to prevent groove formation, manual brushing is preferred to mechanical brushing.

Post-Weld Heat Treatment:

- Post-weld heat treatment is usually not required; in exceptional cases, solution annealing at $1020 - 1050^\circ\text{C}$ with a hold time of 5 minutes and subsequent water quenching can be carried out.

3. Preliminary Calculation of the Ferrite Content in the Weld Metal

The WRC-92 diagram is used to calculate the microstructure components in the weld metal of duplex steels. It contains the lines for the ferrite number FN (ISO ferrite number) and lines that characterise the primary solidification microstructures (primary austenitic or primary ferritic):

- A - austenitic
- AF - austenitic-ferritic
- FA - ferritic-austenitic
- F - ferritic

Further information includes:

- EN 1011-3:
Welding - Recommendations for welding metallic materials - Part 3: Arc welding of stainless steels

WRC-92 Diagram

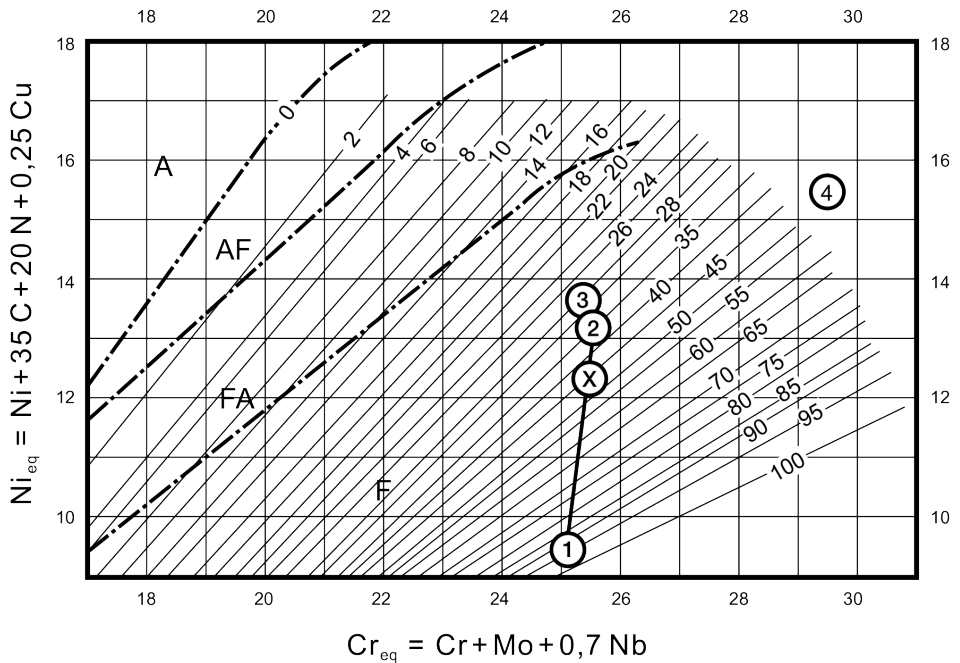

- ① Layer of parent material X2CrNiMoN22-5-3 (1.4462)
- ② Layer of deposited metal from OK 67.50
- ③ Layer of deposited MIG/TIG metal from OK Autrod 2209 / OK Tigrod 2209
- ④ Layer of deposited metal from OK 68.53 (Super-Duplex)
- ⊗ Layer of heterogeneous weld metal made of 1.4462 / OK 67.50 with 30 % pick-up from the parent material, ferrite number is FN = 45



The world is full of welds. But when it comes to filler metals, there's only one true brand that fulfills its duty, again and again. ESAB. Our global-leading lineup has been providing projects around the world with more to reach their fullest potential. Let's bring the most to your next project.

Filler Metals Made for More.



ESAB / [esab.com](https://www.esab.com)

